

Applied Sweepers



For Scotland built machines Ser. No. 0910363 and below

Parts Catalogue

For proper replacement parts:

Identify the dataplate located behind the right side panel.



Applied Sweepers LTD. Bankhall Park, Scotland PK2 7JH Tel: 01324 611866	
MODEL	636HS
CHASSIS	0508355
ENGINE	4Q9573
C.I.N.	8
GVW	2450kg
1 AXLE	1250kg
2 AXLE	1350kg
CE	
GM433	

You are in the Parts Catalog for the Scotland built machines.



USA built machine

636HS Green Machine

The information contained within this document conforms wherever possible to European Directive 89/392/EEC as amended by Directive 91/368/EEC.

Copyright Applied Sweepers 2004-2006. This document is confidential and the document and copyright therein are the property of Applied Sweepers Ltd.

This document and any information therein may not be used, copied or disclosed to any third party without the prior written authorisation of Applied Sweepers Ltd.

When ordering parts from this catalogue, please also provide your distributor with the model number and chassis number of your machine (located on the chassis plate).

Threaded fasteners - Replacement hexagon head screws must be Grade 8.8 minimum and Socket head screws must be Grade 12.9 minimum, except where stated otherwise. All nuts must be Grade 8 minimum. All fasteners should be zinc plated and passivated unless stated otherwise.

Applied Sweepers reserves the right to change without notice either the specification of any of the parts listed in this catalogue, or to discontinue supply of any parts listed here without notice.

636HS Green Machine

Parts Catalogue

Air Conditioning

Low Level Air - Con	636109-1
Low Level Air Con	525056-12
Low Level Air Con - Engine	636110-1

Cab & Controls

Cab - Underside	636088-8
Cab Carpets and Windows	354861
Cab Door - Left Hand	354854
Cab Door - Right Hand	354853
Cab Foot Pedals	354856
Cab Heater	354863
Cab Instrument Panel	354865
Cab Parking Brake	354860
Cab Seat	354866
Cab Tilt Group	354858
Cab-Console	636081-8
Cab-Controls	636080-8
Cab-Doors	636085-8
Cab-Front	636087-8
Cab-Instrument Panel	636083-8
Cab-Seat /Armrest Controls	636084-8
Cab-Switch Panel	636082-8

Chassis, Axles, Brakes

Brake Lines	354868
Braking System - Footbrake & Cables	636041-8
Braking System - Front Brakes	636039-8
Braking System - Handbrake & Cables	636042-8
Braking System - Rear Brakes	636040-8
Front Axle	354825
Front Axle & Steering Linkage	636086-8
Front Drive Wheel Motor - Left Hand	354821
Front Drive Wheel Motor - Right Hand	354822
Main Chassis	354867
Rear Trailing Arm - Left Hand	354817
Rear Trailing Arm - Right Hand	354818
Rear Trailing Arms	636038-8
Steering Linkage	354824
Wheel and Brake - Rear	354819

Electrical & Electronic Control

Electrical System-Cab Electronic Management	636090-8
Electrical System-Chassis Electronic Management	636091-8

Engine & Ancillaries

Engine - Cooling System	636049-8
Engine - Fuel Tank & Filter	636048-8
Engine - Left Side	636044-8
Engine - Rear	636046-8
Engine - Right Side	636045-8
Engine - Top View	636047-8
Engine Air Filter	354842
Engine Battery and Alternator	354871
Engine Bay -Ancillary Components	636089-8
Engine Fuel Supply	354830
Engine Mount	354828
Engine Muffler	354829
Engine Radiator Hoses	354836

636HS Green Machine

Parts Catalogue

Engine Radiator Mount	354835
General	
Rear - Decals & Ancillaries	636098-8
Recommended Stockholding - Smaller Fleets 636HS	636100-8
Side - Decals & Ancillaries	636097-8
Side Panel - Left Hand	354869
Side Panel - Right Hand	354870
Special Tools and Schematic Drawings - 636HS	636099-8
Hopper	
Hopper and Dump Door	354837
Hopper Lift	354838
Hydraulics	
Hydraulic System - Auxiliary Cylinder Manifold	636050-8
Hydraulic System - Auxiliary Motor Manifold	636051-8
Hydraulic System - Brush Cylinders	636056-8
Hydraulic System - Brush Height	636061-8
Hydraulic System - Fan & Brush Motors	636064-8
Hydraulic System - Hopper & Brush Valve	636060-8
Hydraulic System - Hopper Cylinders	636062-8
Hydraulic System - Hopper Manifold	636053-8
Hydraulic System - Hydraulic Cylinder & Hand Pump	636055-8
Hydraulic System - Hydraulic Cylinders	636054-8
Hydraulic System - Hydraulic Tank	636057-8
Hydraulic System - Steering	636058-8
Hydraulic System - Tanks, Pumps & Steering	636059-8
Hydraulic System - Transmission Manifold	636052-8
Hydraulic System - Wheel Motors	636063-8
Pressure Washer Option	
Pressure Washer - Hydraulic System (from CIN 2)	636095-8
Pressure Washer - Hydraulic System(to CIN 1)	636093-8
Pressure Washer - Lance/Hose Reel	636092-8
Pressure Washer - Pressure Washer Manifold	636096-8
Pressure Washer - Water System	636094-8
Sweeping Systems	
Brush Arm Lift, Left Hand	354834
Brush Arm Lift, Right Hand	354833
Brush Arm Motor - Left Hand	354832
Brush Arm Motor - Right Hand	354831
Brush Replacement	354855
Front Brushes & Brush Arms	636105-1
Vacuum System - Drain Access Door	636071-8
Vacuum System - Fan Inspection Door	636074-8
Vacuum System - Front Nozzle	636065-8
Vacuum System - Hopper Drain Flap	636070-8
Vacuum System - Hopper Ducts	636069-8
Vacuum System - Hopper Front	636068-8
Vacuum System - Hopper Rear	636073-8
Vacuum System - Hopper Rear Door	636072-8
Vacuum System - Inlet Duct	636067-8
Vacuum System - Nozzle Flap	636066-8
Vacuum System-Clean Fan	636075-8
Vacuum System-Cyclones	636077-8
Vacuum System-Hopper Linkages	636076-8
Vacuum Systems - Hopper Safety Switch	636103-1
Water System	
Water System - Cloudmaker	636036-8

636HS Green Machine

Parts Catalogue

Water System - Fan Casing Spray	525035-8
Water System - Front Brush Sprays	525036-8
Water System - General Arrangement	636031-8
Water System - Main Water Tank	636043-8
Water System - Side Water Tank	636034-8
Water System - Solenoid Valve for Atomiser	636037-8
Water System - Water pump and manifold	525032-8

Low Level Air - Con

Model: **636HS Green Machine**
 From CIN: **9** To CIN: **12**
 Drawing: **636109-1** Revision:

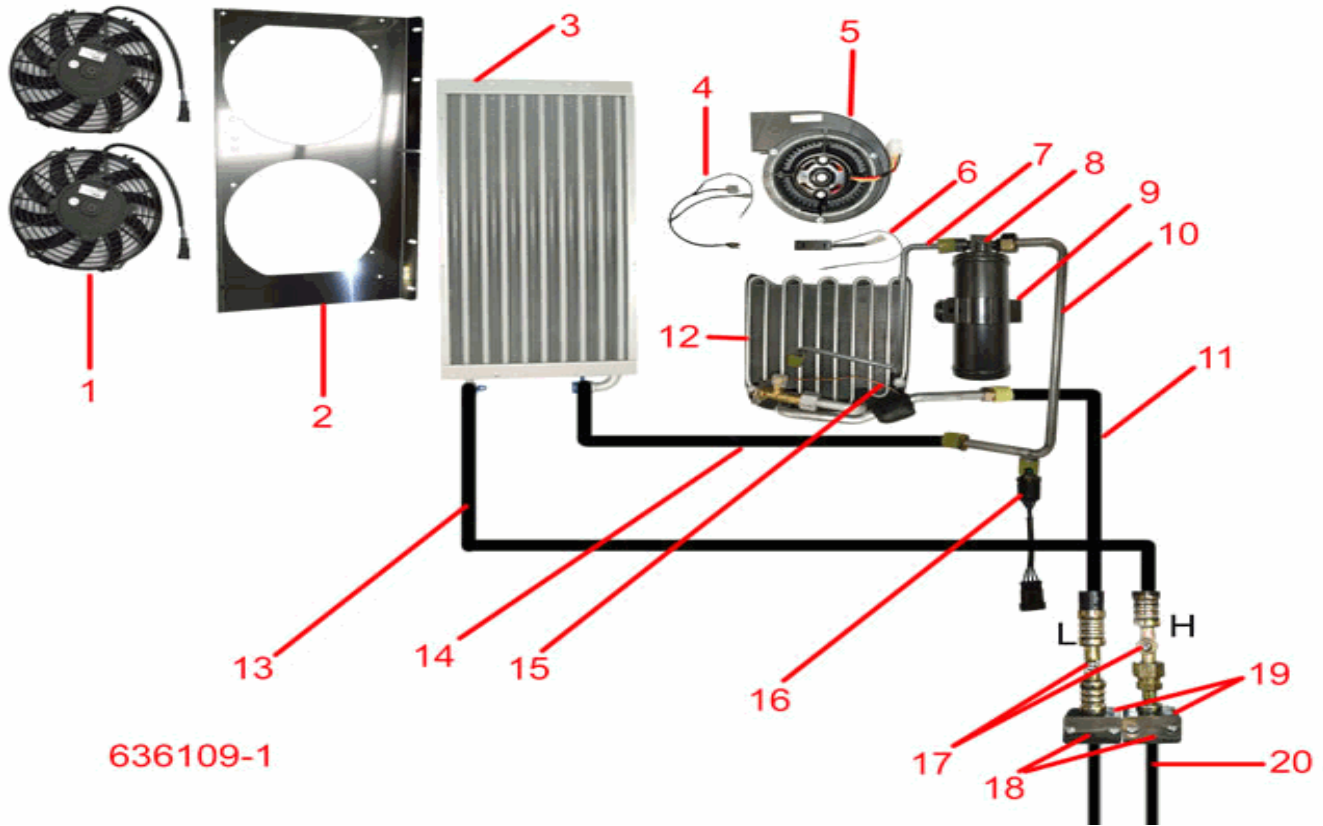

1	AC021 - Fan,Condenser	2	AC134 - Hose, High pressure, Compressor to Ca	1
2	AC106 - Mounting Plate, Condenser	1		
3	AC019 - Condensor	1		
4	EW181 - Loom, Evaporator	1		
5	AC125 - FAN BLOWER, EVAPORATOR	1		
6	AC128 - Thermo Amp Kit	1		
7	AC044 - Pipe, Assy - Receiver/Dryer to Evapor	1		
8	AC032 - Receiver Drier - Air Conditioning	1		
9	AC033 - Bracket, Reciever Drier	1		
10	AC126 - Pipe, Condensor to Drier	1		
11	AC137 - Hose, Low Pressure, Evaporator to Com	1		
12	AC020 - Evaporator	1		
13	AC135 - Hose, High pressure, Cab to Condenser	1		
14	AC136 - Hose, Low pressure, Condenser to drie	1		
15	AC091 - Expansion Valve	1		
16	AC127 - Trinary Switch Assembly	1		
17	KM285 - Valve Core, High Flow, Denso	2		
18	CD437 - Plate, Pipe Clamp, M20 pipe	2		
19	HF192 - Clamp Body, M20 pipe	4		

Low Level Air Con

Model: **636HS Green Machine**
 From CIN: **1** To CIN: **8**
 Drawing: **525056-12** Revision: **a**

525056-12

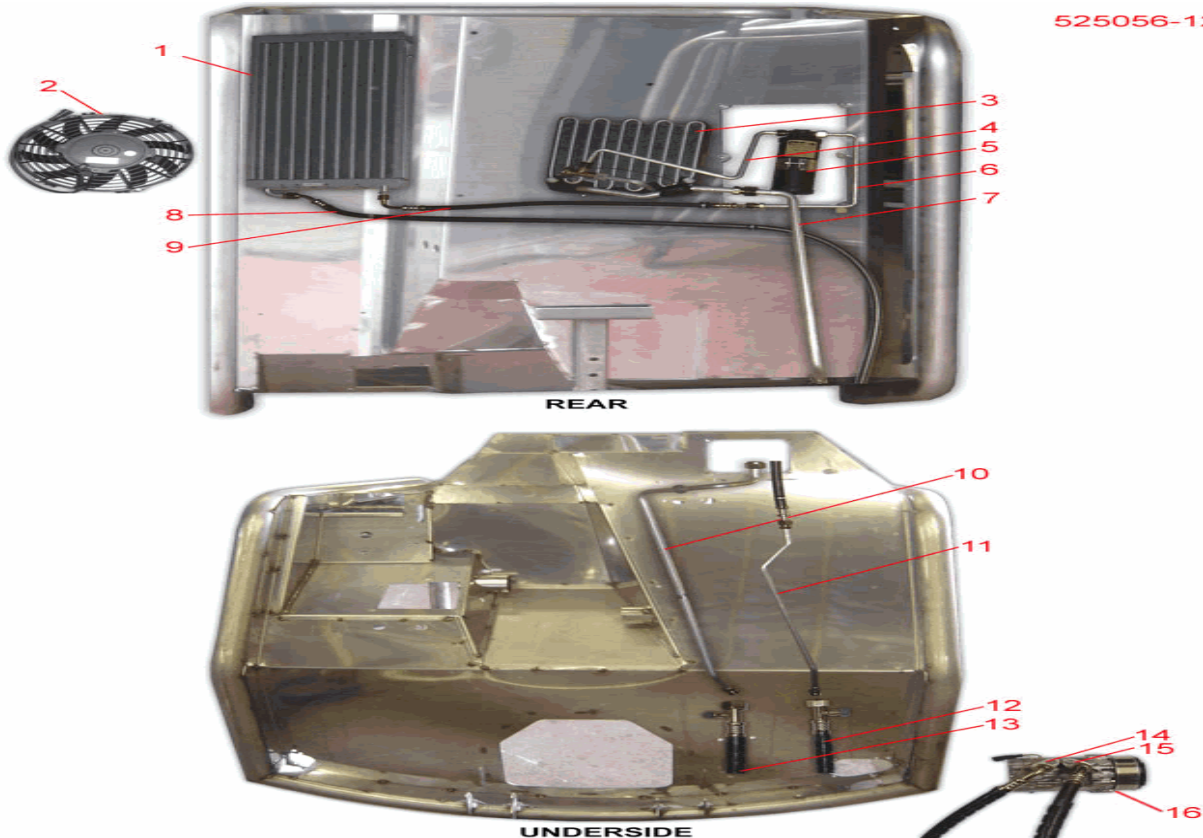

1	AC019 - Condensor	1
2	AC021 - Fan,Condenser	2
3	AC020 - Evaporator	1
4	AC044 - Pipe, Assy - Receiver/Dryer to Evapor	1
5	AC032 - Receiver Drier - Air Conditioning	1
6	AC113 - Pipe,Assy - Condensor to Drier	1
7	AC039 - Pipe, Assy - Evap to Floor	1
8	AC116 - Hose - Condenser to AC115 Pipe	1
9	AC114 - Hose - Condenser to AC113 Pipe	1
10	AC040 - Pipe,Assy - Low Pressure	1
11	AC115 - Pipe,Assy - High Pressure - Under cab	1
12	AC045 - Hose, Assy - Flexible - Compressor to	1
13	AC046 - Hose Assy, Flexible - Compressor to C	1
14	AC117 - Adaptor - High Pressure on Compressor	1
15	AC118 - Adaptor - Low Pressure on Compressor	1
16	AC058 - Compressor, Air Conditioning	1

Low Level Air Con - Engine

Model: **636HS Green Machine**
 From CIN: **9** To CIN: **12**
 Drawing: **636110-1** Revision:

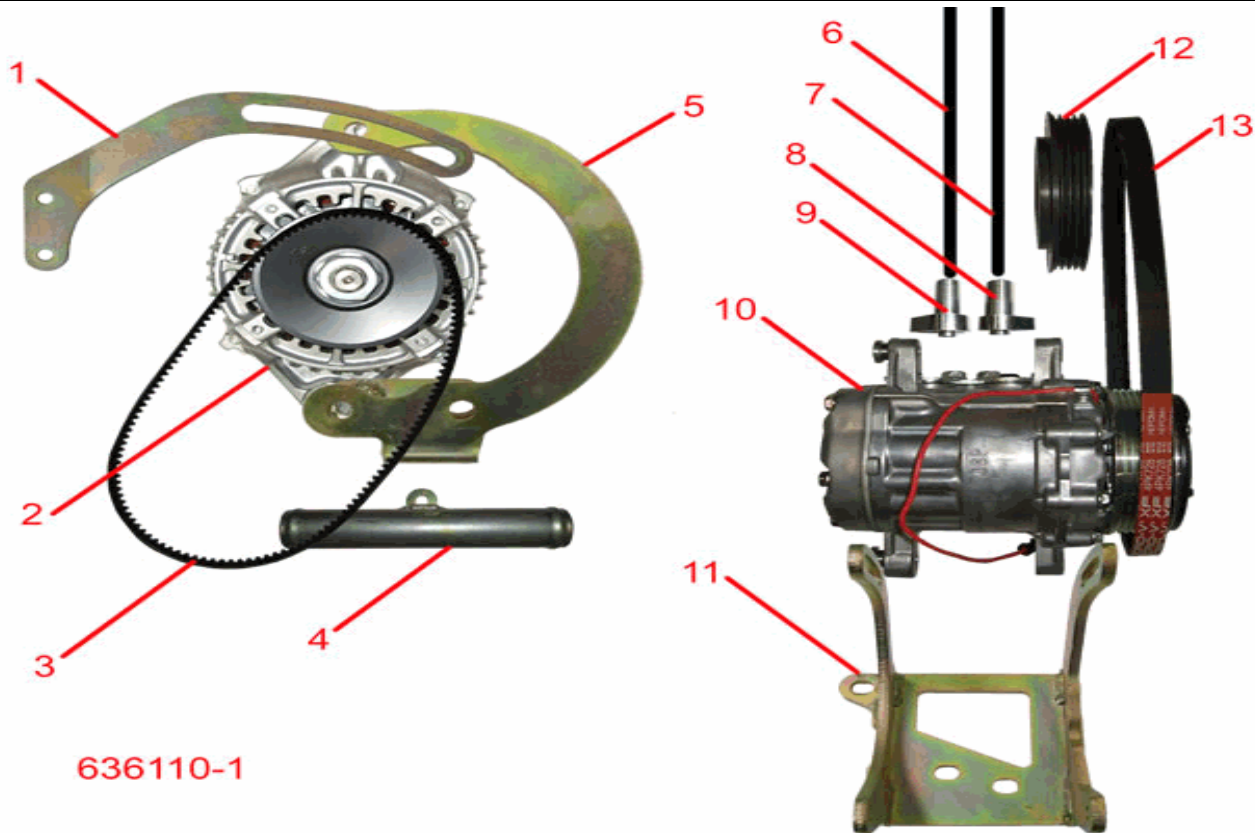

1	PP147 - Bracket, Altenator Adjustable	1
2	PP159 - 90 Amp Alternator	1
3	PP196 - Fan Belt - Air Con Machine	1
4	AC059 - Pipe, Water, Lower Engine	1
5	PP156 - Bracket, Alternator Mounting	1
6	AC137 - Hose, Low Pressure, Evaporator to Com	1
7	AC134 - Hose, High pressure, Compressor to Ca	1
8	AC117 - Adaptor - High Pressure on Compressor	1
9	AC118 - Adaptor - Low Pressure on Compressor	1
10	AC058 - Compressor, Air Conditioning	1
11	AC072 - Compressor Bracket, Air Conditioning	1
12	TC021 - Drive Pulley, Compressor	1
13	AC086 - Belt, Compressor - Micro-V - Air Cond	1

Cab - Underside

Model: **636HS Green Machine**
 From CIN: **1** To CIN: **12**
 Drawing: **636088-8** Revision:

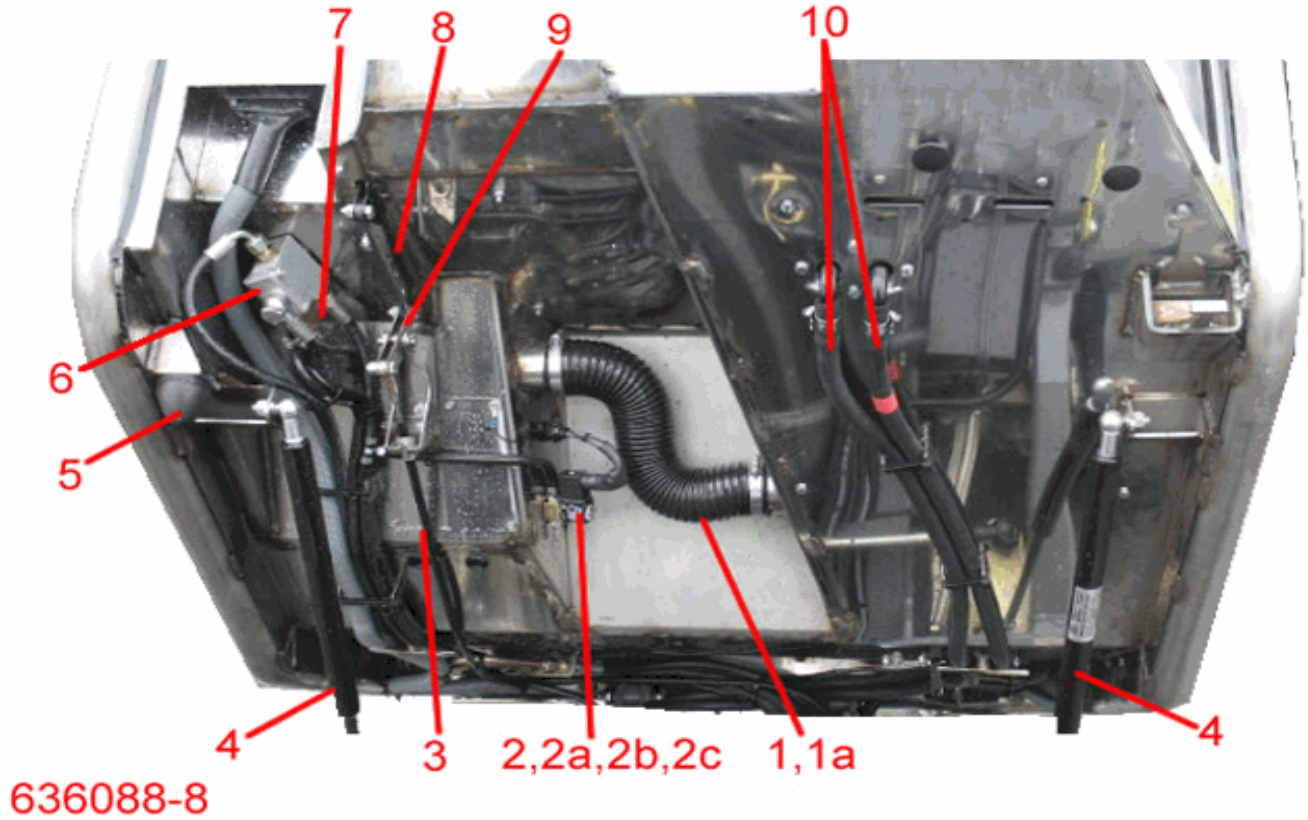

1	MC343 - Hot Air Duct, Crossover 400mm lg.	1
1a	GG123 - Hose Clamp (55 to 70 mm)	2
2	WP214 - Solenoid Valve	1
2a	WP215 - Coil - Solenoid	1
2b	WP216 - Plug - Solenoid Valve	1
2c	WP217 - Hose Tail, 1/8	2
3	BB129 - Brake Cable, Front	1
4	GG282 - GG282 - Gas Strut,Cab Tilt	2
5	GG233 - Conical Progressive Stop, Cab Mounti	2
6	HV133 - Valve Assembly, Brush Height	1
7	WA121 - Needle Valve	1
8	MC312 - Tie Rod, machined, Handbrake Bellcran	1
9	MC309 - Handbrake Bellcrank Weldment	1
10		2
10	PC247 - PC247 - Heater Hose-Radiator to Heate	2
10a	GG077 - Hose Clamp (14mm to 22mm)	2

Cab Carpets and Windows

Model: **636HS Green Machine**
 From CIN: **13** To CIN: **999**
 Drawing: **354861** Revision: **00**

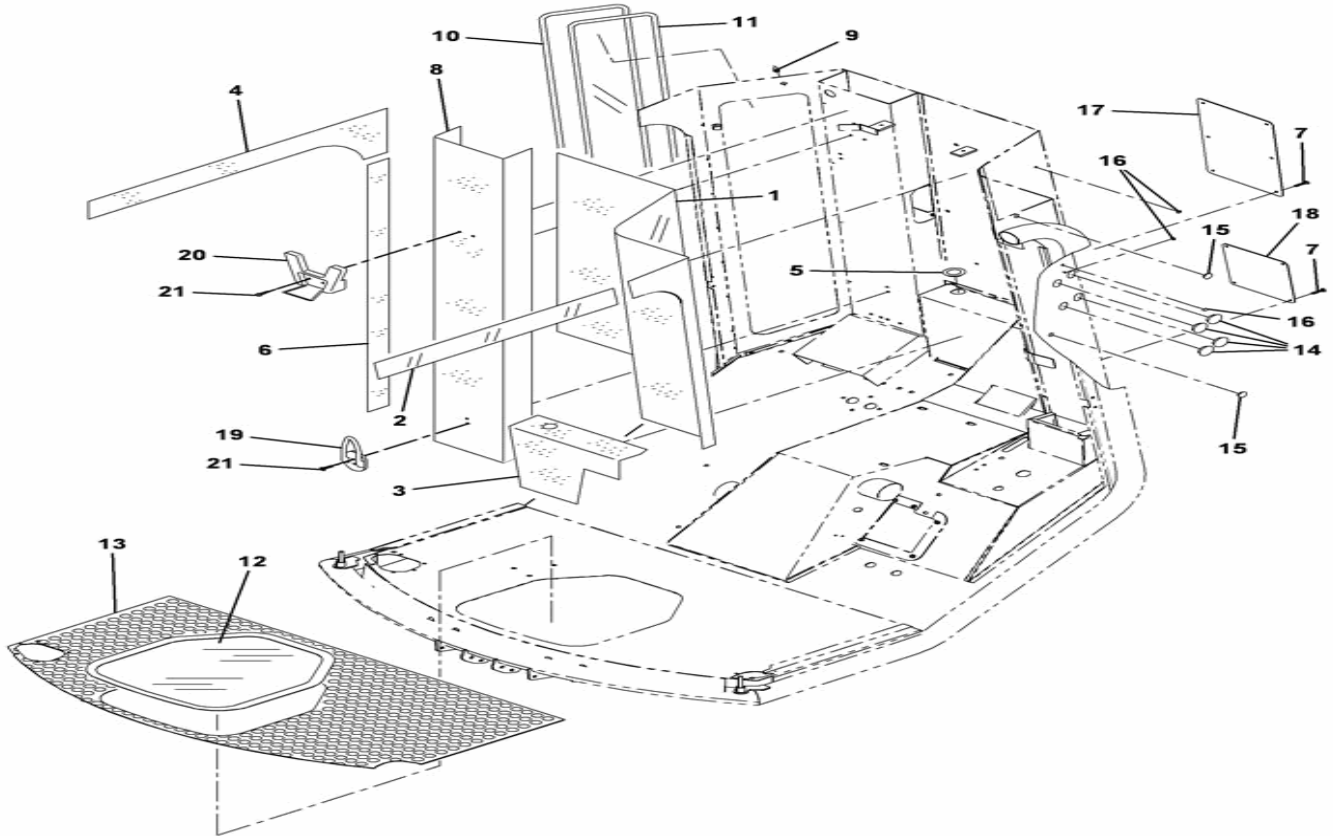

1	MC426 - Carpet Profile Cab Rear	1	20	GG296 - COAT HOOK - DOUBLE	1
2	MC422 - Carpet Profile Left Hand Top	1	21	GT267 - M4 x 12 button head screw st.st.	4
3	MC424 - Carpet Profile, Cab Back Insert	1			
4	MC425 - Carpet Profile Right Hand Top	1			
5	GM387 - Blind Grommet -16.5 MM HOLE DIA	1			
6	MC421 - Carpet Profile, Right Hand Backpost	1			
7	GT320 - Screw, Button Head Hex Socket - M6 x	0			
8	MC420 - Carpet Profile Air Duct	1			
9	GM361 - Grommet Sleeved	1			
10	MC119 - Cab Rear Window	1			
11	KM332 - Seal, Cab Rear Window	1			
12	MC120 - Glass Floor Window	1			
13	GM311 - Rubber Mat	1			
14	GM389 - Blind Grommet - 25 MM HOLE DIA	4			
15	GM387 - Blind Grommet -16.5 MM HOLE DIA	2			
16	GM385 - Blind Grommet - 6.4MM HOLE DIA	3			
17	MC434 - Plate Cover, Cab Rear	1			
18	MC680 - Cover Plate, Cab Back	1			
19	GG295 - COAT HOOK, FOR T-BAR ALLEN KEY	1			

Cab Door - Left Hand

Model: **636HS Green Machine**
 From CIN: **13** To CIN: **999**
 Drawing: **354854** Revision: **00**

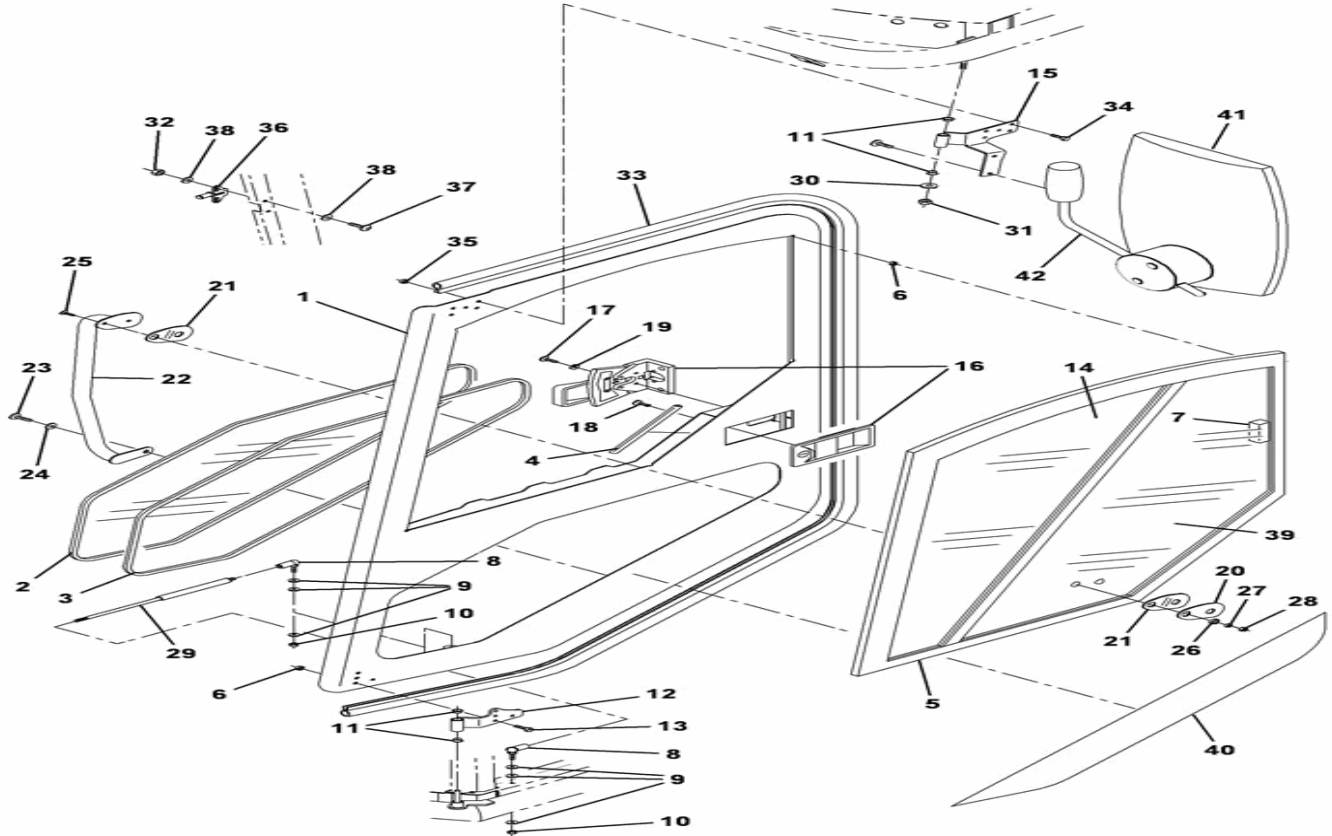

1	MC317 - Cab Door Assembly, LH	1	24	GW079 - M10 Washer - Form A (Stainless Steel)	1
1a	MC930 - Door Weldment, Cab Left Hand	1	25	GT328 - Screw, Button Head Hex Socket - M6 x	2
2	MC118 - Fixed Glass, Lower Door	1	26	GB109 - Isolator Bush, Outer - Window Fixing	2
5	MC121_B - Window Cassette - Left Hand, Black	1	27	GB110 - Sleeve, Inner - Window Fixing Pivot	2
6	GN011 - M6 Locknut - Nylon	0	28	GN011 - M6 Locknut - Nylon	2
7	MC553 - Window Catch	1	29	MC270 - Door Stay, Gas Strut Base Unit	1
8	MC271 - Ball Joints, Door Stay	2	33	MC384 - Door Seal, Rear	1
11	GB060 - Bush	4	36	MC145 - Striker Pin Weldment -Right Hand Cab	1
12	MC163 - Hinge,Bottom,LH Door	1	39	MC355 - Window Glass - sliding	1
14	MC370 - Window Cassette, Fixed Glass	1	40	GM509 - Decal, Door Bottom, Nearside	1
15	MC150 - Hinge,Top - LH Door	1	41	MC364 - Wing Mirror, Unbreakable	1
16	MC663 - Door Lock Kit - Complete (Black)	1	42	MC258 - Wing Mirror Arm	1
17	GT305 - Scre, Button Head Socket - M5 x 35 Zi	2			
18	GT112 - M5 x 16 Button Head Screw	1			
19	GW031 - Washer M6 Form C	2			
20	MC405 - Outer fixing plate - for handle	1			
21	GG280 - Gasket, Window Fixing Pivot	2			
22	MC791 - Window Pivot Weldment - Left Hand	1			
23	GT382 - Screw,Button Head Hex Socket -M10 x 1	1			

Cab Door - Right Hand

Model: **636HS Green Machine**
 From CIN: **13** To CIN: **999**
 Drawing: **354853** Revision: **00**

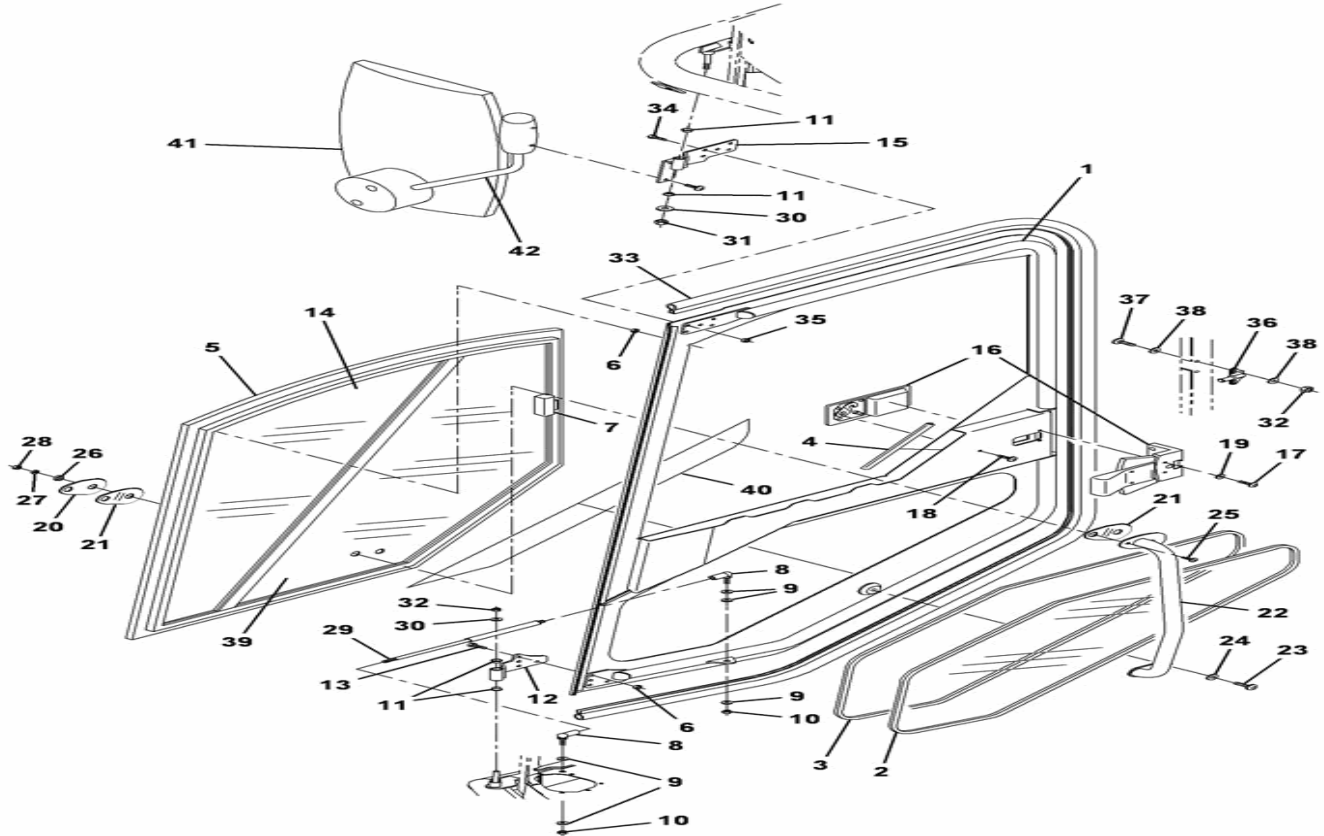

1	MC318 - Cab Door Assembly, RH	1	25	GT328 - Screw, Button Head Hex Socket - M6 x	2
1a	MC931 - Door Weldment, Cab Right Hand	1	26	GB109 - Isolator Bush, Outer - Window Fixing	2
2	MC118 - Fixed Glass, Lower Door	1	27	GB110 - Sleeve, Inner - Window Fixing Pivot	2
5	MC122_B - Window Cassette - Right Hand, Black	1	28	GN011 - M6 Locknut - Nylon	2
6	GN011 - M6 Locknut - Nylon	0	29	MC270 - Door Stay, Gas Strut Base Unit	1
7	MC553 - Window Catch	1	33	MC384 - Door Seal, Rear	1
8	MC271 - Ball Joints, Door Stay	2	36	MC145 - Striker Pin Weldment -Right Hand Cab	1
11	GB060 - Bush	4	39	MC355 - Window Glass - sliding	1
12	MC166 - Hinge, Bottom RH Door	1	40	GM510 - Decal, Door Bottom, Offside	1
14	MC370 - Window Cassette, Fixed Glass	1	41	MC364 - Wing Mirror, Unbreakable	1
15	MC155 - Hinge, Top - RH Door	1	42	MC258 - Wing Mirror Arm	1
16	MC663 - Door Lock Kit - Complete (Black)	1			
17	GT305 - Scre, Button Head Socket - M5 x 35 Zi	2			
18	GT112 - M5 x 16 Button Head Screw	1			
20	MC405 - Outer fixing plate - for handle	1			
21	GG280 - Gasket, Window Fixing Pivot	2			
22	MC790 - Pivot Weldment, Window Right Hand	1			
23	GT382 - Screw, Button Head Hex Socket -M10 x 1	1			
24	GW079 - M10 Washer - Form A (Stainless Steel)	1			

Cab Foot Pedals

Model: **636HS Green Machine**
 From CIN: **13** To CIN: **999**
 Drawing: **354856** Revision: **00**

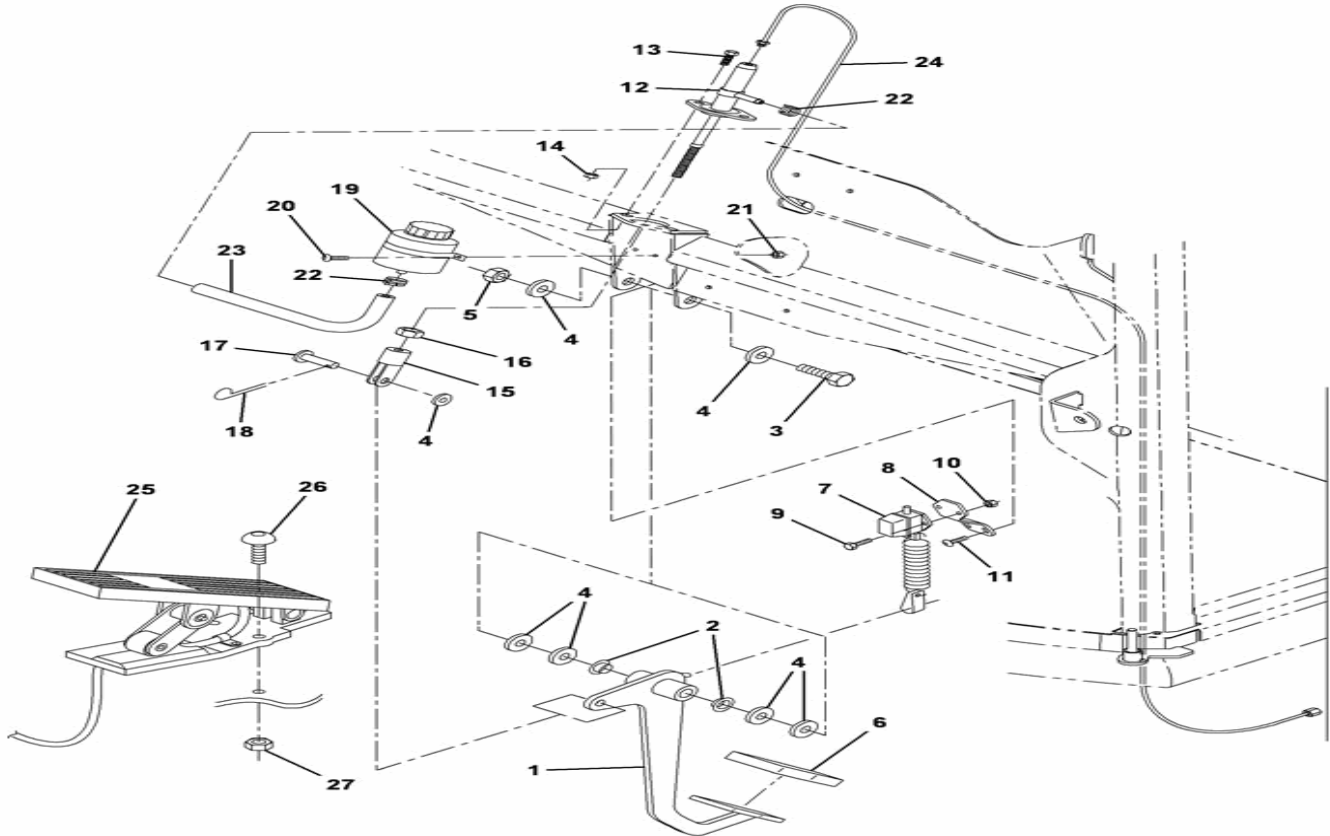

1	MC050 - Brake Pedal	1	27	GN004 - M8 Locknut - Nylon	3
2	GB031 - Bush, Flanged DU - 12 I/D x 14 O/D x	1			
6	BB121 - Brake Pedal Rubber	1			
7	ES230 - Brake Light Switch	1			
8	MC373 - Mounting Plate, Brake Light Switch	1			
9	GT073 - Screw, Hex Head Set - M4 x 16	2			
11	GT194 - M5 x 12 button head screw	2			
12	BB192 - Master Cylinder	1			
15	MC062 - Clevis, Master Cylinder	1			
17	MA200 - Clevis Pin	1			
18	GG249 - Pin ,Split 1 1/2" x 1/8"	1			
19	BB120 - Footbrake Reservoir	1			
20	GT159 - Screw, M6 x 16	2			
21	GN011 - M6 Locknut - Nylon	2			
23	BB154 - Hose - Brake Reservoir to Master Cyli	1			
24	BB196 - Brake Pipe - Cab Master Cylinder To U	1			
25	ES423 - Pedal, Dual Track	1			
25a	ES424 - Footpedal Potentiometer	1			
26	GT054 - M8 x 20 Button Head Socket Screw	3			

Cab Heater

Model: **636HS Green Machine**
 From CIN: **13** To CIN: **999**
 Drawing: **354863** Revision: **00**

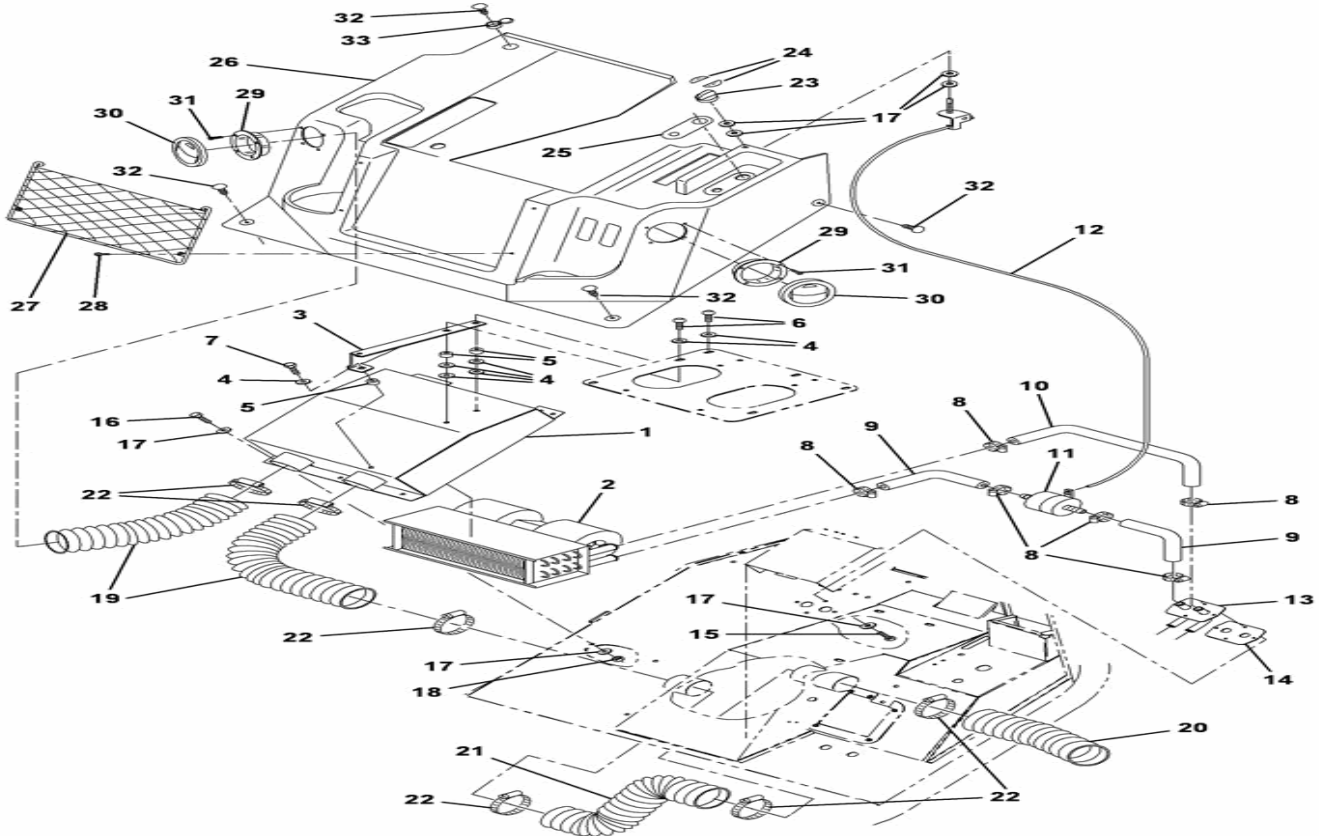

1	MC093 - Heater Box	1	21	MC343 - Hot Air Duct, Crossover 400mm lg.	1
2	MC397 - Heater Unit c/w connector	1	23	GG259 - Knob, Heater Control Valve	1
3	MC501 - Cab Seat Wedge	1	24	GM356 - Label Sheet, Black Vinyl	1
4	GW055 - Washer - M8 FORM C ST/ST 314	7	25	GM356 - Label Sheet, Black Vinyl	1
5	MC735 - Spacer, Seat Assembly	3	26	CP197 - Seat Box Moulding	1
6	GT152 - M8 x 35 button head screw	2	27	CD001 - Glove Net - Document Rack/Net	1
7	GT042 - M8 x 30 Hex Screw	1	28	GT119 - 8 x 3/4 self-tapping screw	4
9	PC114 - Heater Box Hose, Valve to Heater	2	29	MC334 - Spigot Weld - Heater Vent	2
10	PC115 - Heater Box Hose, Return	1	30	MC222 - Heater Outlet Vent	2
11	MC221 - Flow/Temperature Control Valve	1	31	GT410 - Screw, Self Tapper Pozzi	8
12	BB116 - Heater Control Cable	1	33	ES012 - Screw Caps - plastic	1
13	MC277 - Bulkhead Bracket, Heater Hose	1			
14	MC280 - Bulkhead Brkt. Gasket, Heater Hose	1			
15	GT135 - M6 x 16 Hex Screw	4			
16	GT027 - M6 x 20 Hex Screw	7			
17	GW031 - Washer M6 Form C	2			
18	GN011 - M6 Locknut - Nylon	7			
19	MC342 - Hot Air Duct, 200mm lg.	2			
20	MC344 - Hot Air Duct, Left Hand 300mm lg	1			

Cab Instrument Panel

Model: **636HS Green Machine**
 From CIN: **13** To CIN: **999**
 Drawing: **354865** Revision: **00**

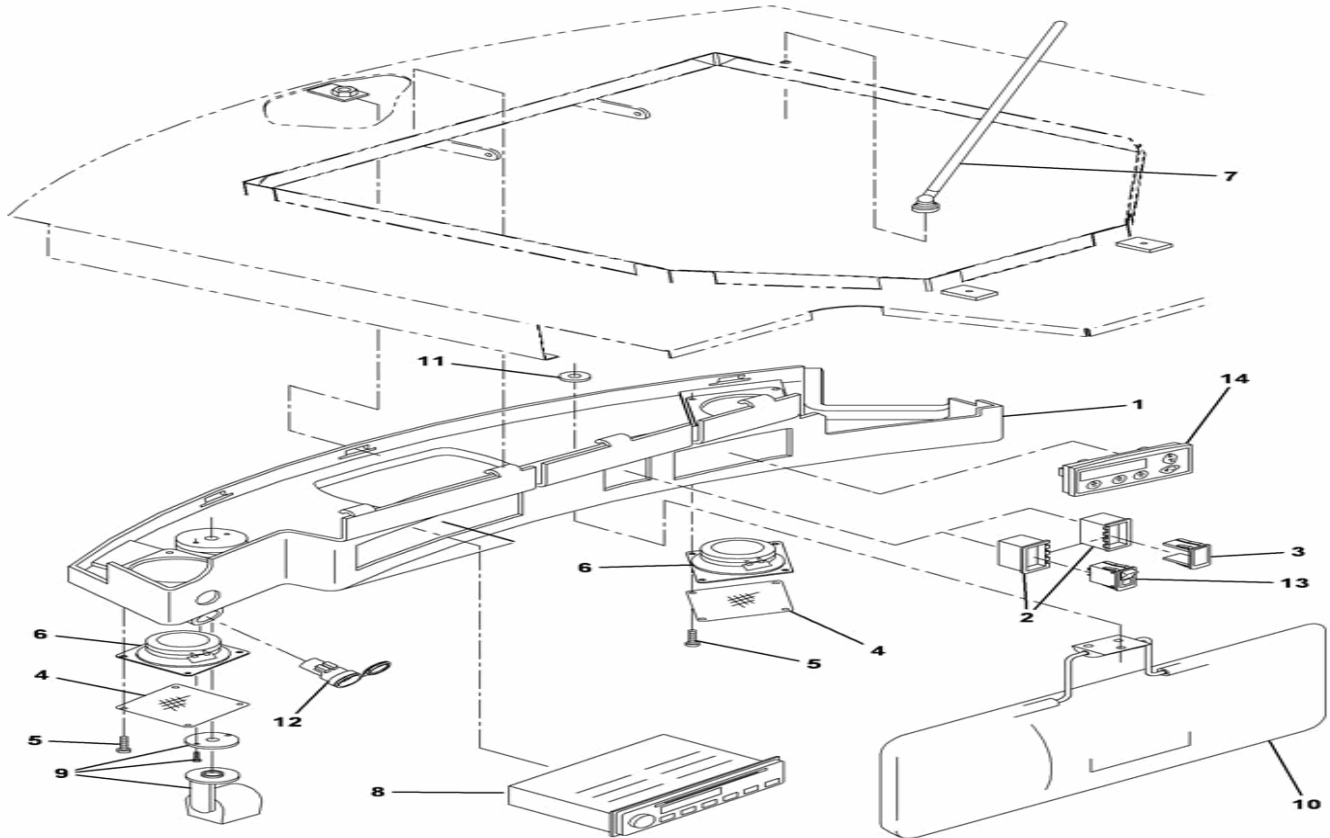

1	CP214 - Console Moulding, Cab Roof	1	8a	ES266 - Bulb & Holder	1
1	MC629 - Switch Panel-Cab	1	9	ES247 - Interior Light	1
2	ES252 - Switch Surround	2	9	ES271 - Switch Blanking Plate	2
2	GM447 - Label,Fan and Brush Speed	1	10	MC479 - Sun Visor	1
3	GM448 - Label,Cloudmaker	1	10	ES530 - Switch Kit - ES221	1
3	ES271 - Switch Blanking Plate	1	11	GW021 - Washer, M8 x 25	3
4	ES252 - Switch Surround	2	11	ES531 - Switch Kit - ES232	1
4	GM310 - Speaker Mesh	2	12	ES272 - Power Socket	1
5	GT106 - #8 x 1/2 in. Phillips Sheet Metal Scr	8	12	ES532 - Switch Kit - ES214	1
5	ES526 - Switch Kit - ES210	3	12	ES532 - Switch Kit - ES214	1
5a	ES266 - Bulb & Holder	1	12	ES532 - Switch Kit - ES214	1
6	ES250 - Speaker	2	13	GT222 - M5 x 8 buttonhead screw	2
6	ES527 - Switch Kit - ES212	1	13	ES526 - Switch Kit - ES210	1
6a	ES266 - Bulb & Holder	1	13a	ES266 - Bulb & Holder	1
7	EC014 - Aerial, Flexible Rubber	1	15	ES017 - Warning Light - Amber	1
7	ES528 - Switch Kit - ES219	1	16	ES192 - Warning Light (Green)	1
7a	ES266 - Bulb & Holder	1	17	ES130 - Warning Light, Amber	1
8	ES248 - Radio/CD	1	17a	ES134 - Bulb for Turn Signal Indicator (Panel	1
8	ES529 - Switch Kit - ES213	2	18	EH018 - Fuel Gauge	1

Cab Instrument Panel

Model: 636HS Green Machine
 From CIN: 13 To CIN: 999
 Drawing: 354859 Revision: 00

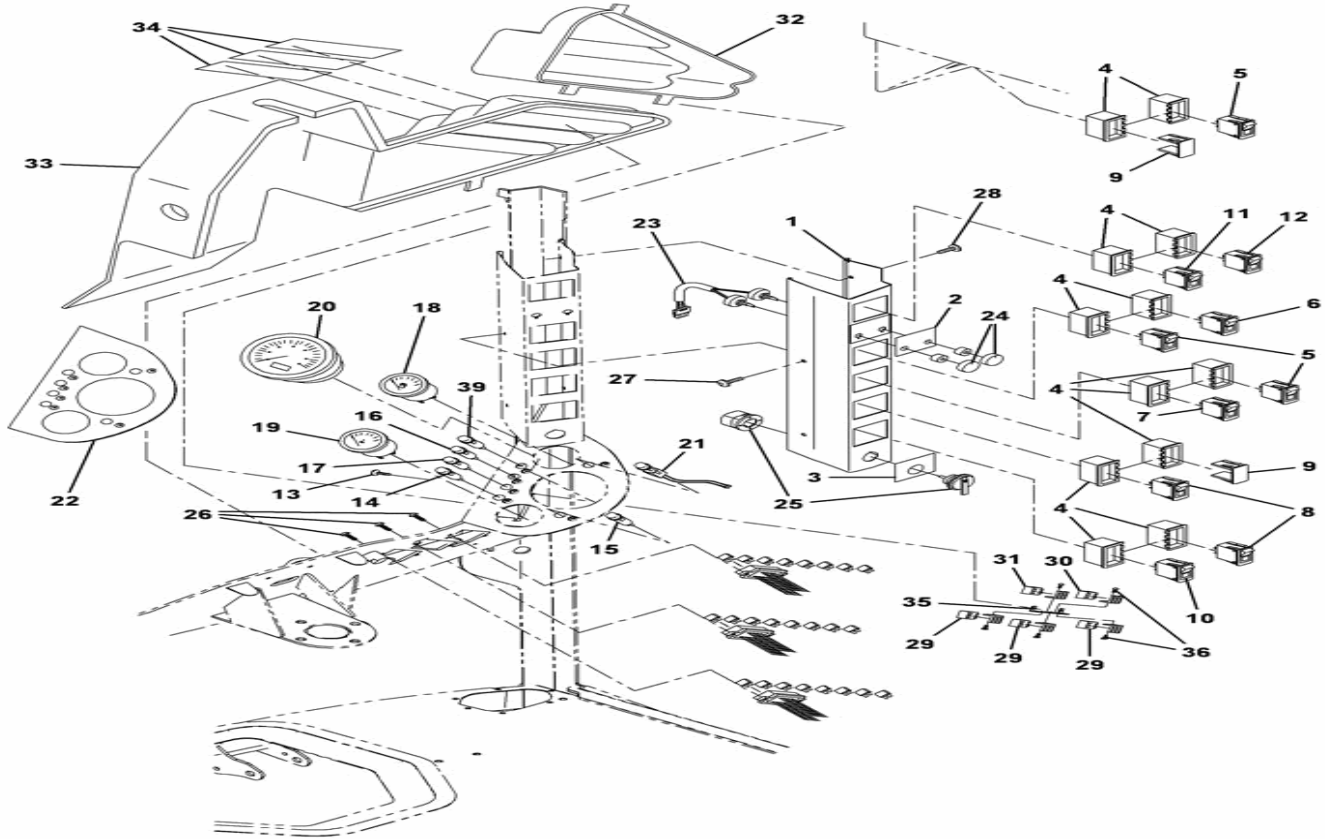

19	EH015 - Temperature Gauge	1
20	EH025 - Tachometer c/w Hour Counter	1
21	ES209 - Main Beam Warning Light (Blue)	1
23	EW221 - Potentiometer Assembly, Brush & Fan C	1
24	ES352 - Knob, Fan/Brush Speed	2
25	ES426 - Switch, Rotary Cam Assembly	1
26	GT194 - M5 x 12 button head screw	6
27	GT194 - M5 x 12 button head screw	2
28	GT222 - M5 x 8 buttonhead screw	3
29	ES180 - Relay - Multi Use - 12V, 35/40	3
30	ES151 - Flasher Unit Indicator Warning	1
31	ES224 - Heated Windscreen Timer/Relay	1
32	CP196 - Relay Box Cover	1
33	CP242 - Cover, Fuse/Brake Cylinder	1
34	GM461 - Label Set, Fuse Box	1
35	MC359 - Relay Holder Weldment	1
36	GT222 - M5 x 8 buttonhead screw	5

Cab Parking Brake

Model: 636HS Green Machine
 From CIN: 13 To CIN: 999
 Drawing: 354860 Revision: 00

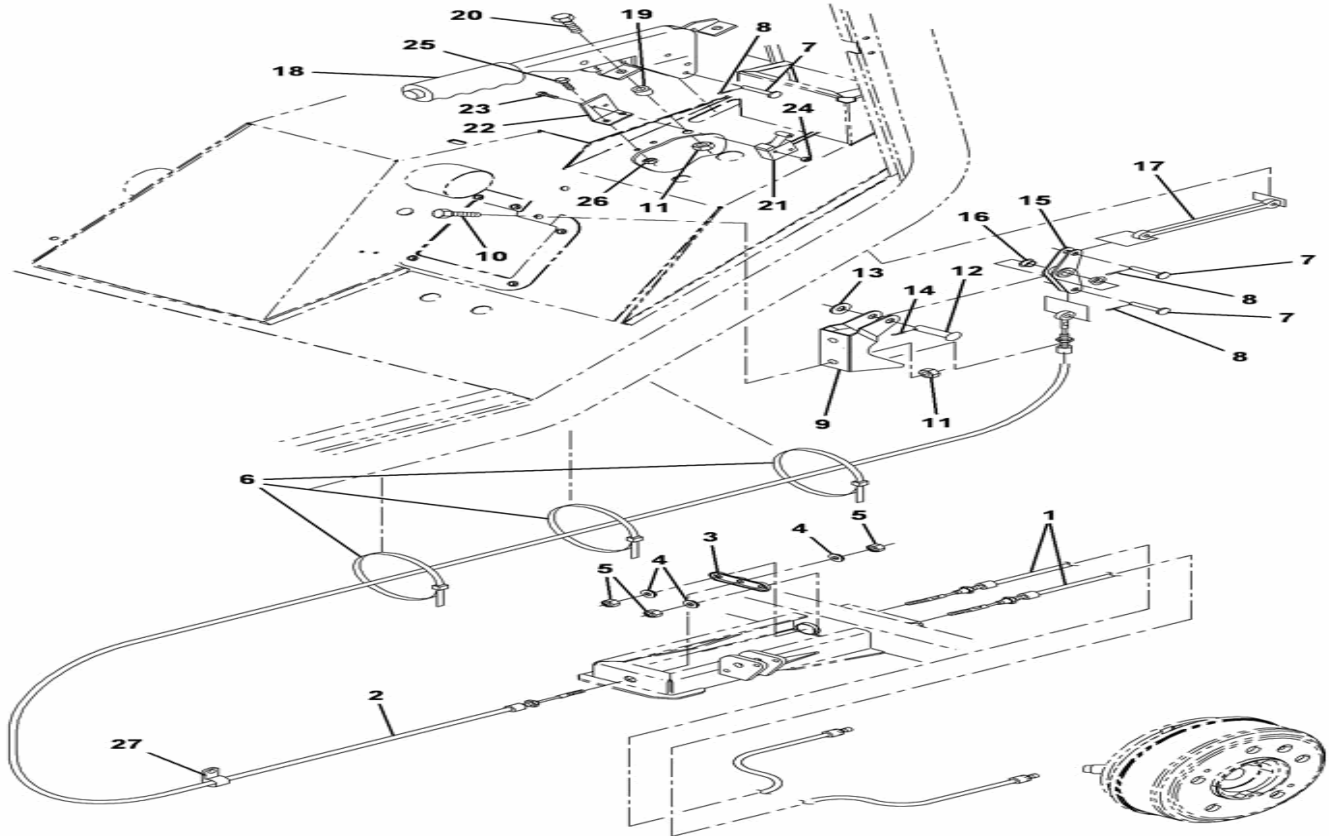

1	BB182 - Brake Cable, Rear - 636	2	23	GT279 - Screw, Hex Head - M3 x 15	2
2	BB129 - Brake Cable, Front	1	24	GN058 - Nut, Nyloc - M3	2
3	BB132 - Brake Cable Balance Bar	1	25	GT196 - Screw, Hex Head - M5 x 10	2
4	GW081 - Cup Washer	3	26	GN006 - M5 Locknut - Nylon	2
5	GW013 - M10 Flat Washer	1	27	BB079 - P - Clip - ABA Rubber Lined - 13mm	1
6	MC309 - Handbrake Bellcrank Weldment	1			
7	GG301 - Cotter Pin, 5/16 x 3/42 Zinc Plated	3			
8	GG132 - Pin, Split - 3/32 x 3/4 - ST.ST.	3			
9	MC298 - Handbrake Pivot Bracket Weldment	1			
10	GT028 - M8 x 20 Setscrew	2			
11	GN004 - M8 Locknut - Nylon	4			
12	GG249 - Pin ,Split 1 1/2" x 1/8"	1			
13	GW013 - M10 Flat Washer	1			
14	GG249 - Pin ,Split 1 1/2" x 1/8"	1			
15	MC309 - Handbrake Bellcrank Weldment	1			
16	GB034 - Bush, Oilite	2			
17	MC312 - Tie Rod, machined, Handbrake Bellcran	1			
18	BB118 - Hand Brake Lever	1			
19	MC251 - Spacer, seat front left	2			
20	GT042 - M8 x 30 Hex Screw	2			
21	ES275 - Microswitch,Handbrake	1			
22	MC223 - Bracket, handbrake warning switch,	1			

Cab Seat

Model: **636HS Green Machine**
 From CIN: **13** To CIN: **999**
 Drawing: **354866** Revision: **00**

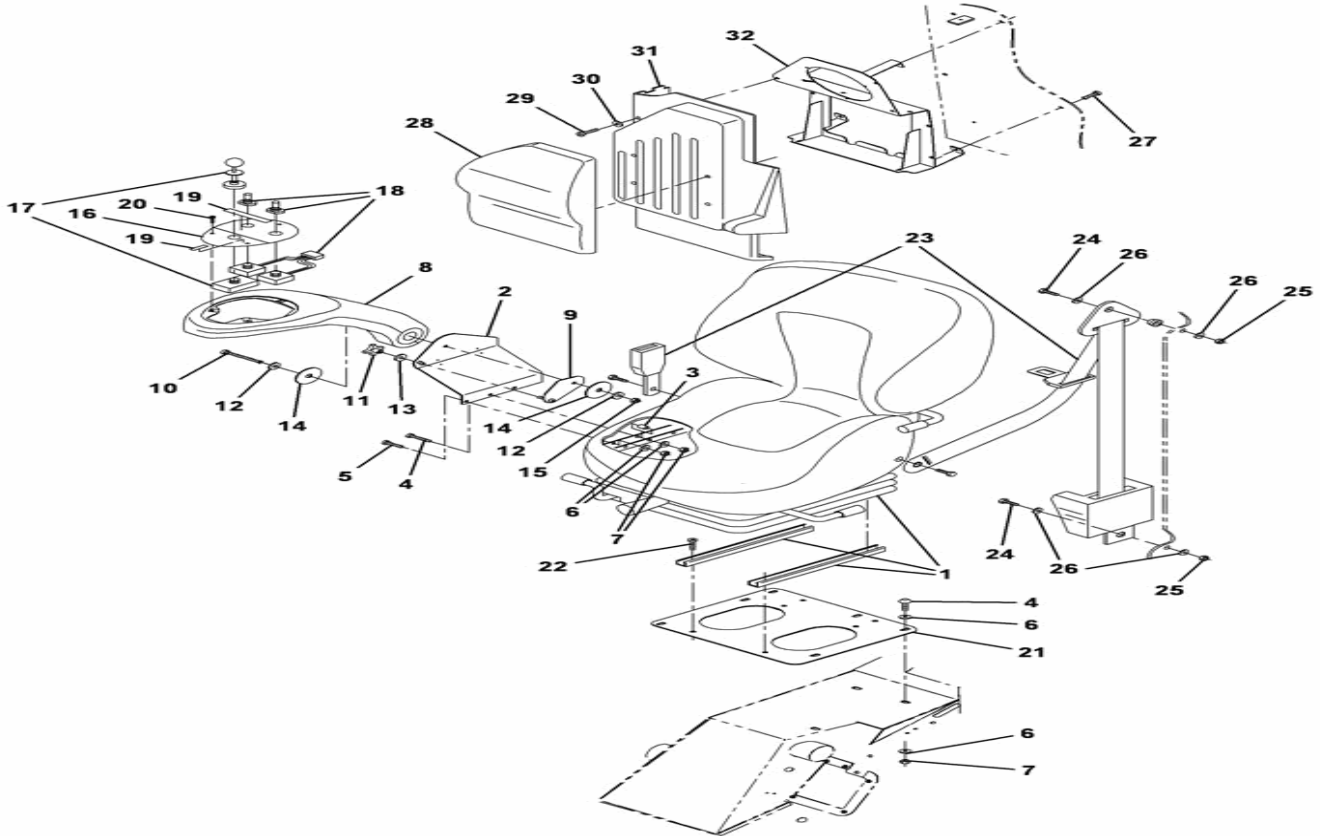

1	MC519 - Cab Seat	1	20	GT119 - 8 x 3/4 self-tapping screw	3
2	MC490 - Armrest Support Bracket	1	21	MC488 - Seat Adaptor Plate	1
3	MC383 - Spacer, Armrest	1	22	GT050 - M8 x 16 Button Head Screw	6
4	GT152 - M8 x 35 button head screw	2	23	MC700 - Seat Belt Kit - 3 Point	1
5	GT331 - Screw,Button Head HEX Socket -M8 x 20	4	24	GT310 - Screw, Hex Head Set - M16 x 80	2
6	GW041 - M8 Washer Form A	0	25	GN019 - M10 Locknut - Nylon	2
7	GN043 - M8 locknut - nylon - stainless steel	6	26	GW013 - M10 Flat Washer	4
8	CP205 - Control Arm Moulding	1	27	GT050 - M8 x 16 Button Head Screw	4
9	MC672 - BRACKET, ADJUSTABLE - ARMREST	1	28	MC502 - ASYMETRIC HEADREST	1
10	GT262 - M8 x 55 Button Head Screw	1	29	GT051 - M5 x 16 Hex Screw	7
11	GG021 - Panel Knob - black M8	1	30	GW031 - Washer M6 Form C	7
12	GW021 - Washer, M8 x 25	2	31	CP201 - Headrest Mounting	1
13	GW041 - M8 Washer Form A	1	32	AC017 - BRACKET, EVAPORATOR WELDMENT	1
14	GW086 - Washer Nylon	2			
15	GN043 - M8 locknut - nylon - stainless steel	2			
16	MC378 - Facia Plate	1			
17	ES355 - Switch, Joystick - Forward/Neutral/Re	1			
18	ES405 - Joystick - Brush Control	1			
19	GM356 - Label Sheet, Black Vinyl	1			

Cab Tilt Group

Model: **636HS Green Machine**
 From CIN: **13** To CIN: **999**
 Drawing: **354858** Revision: **00**

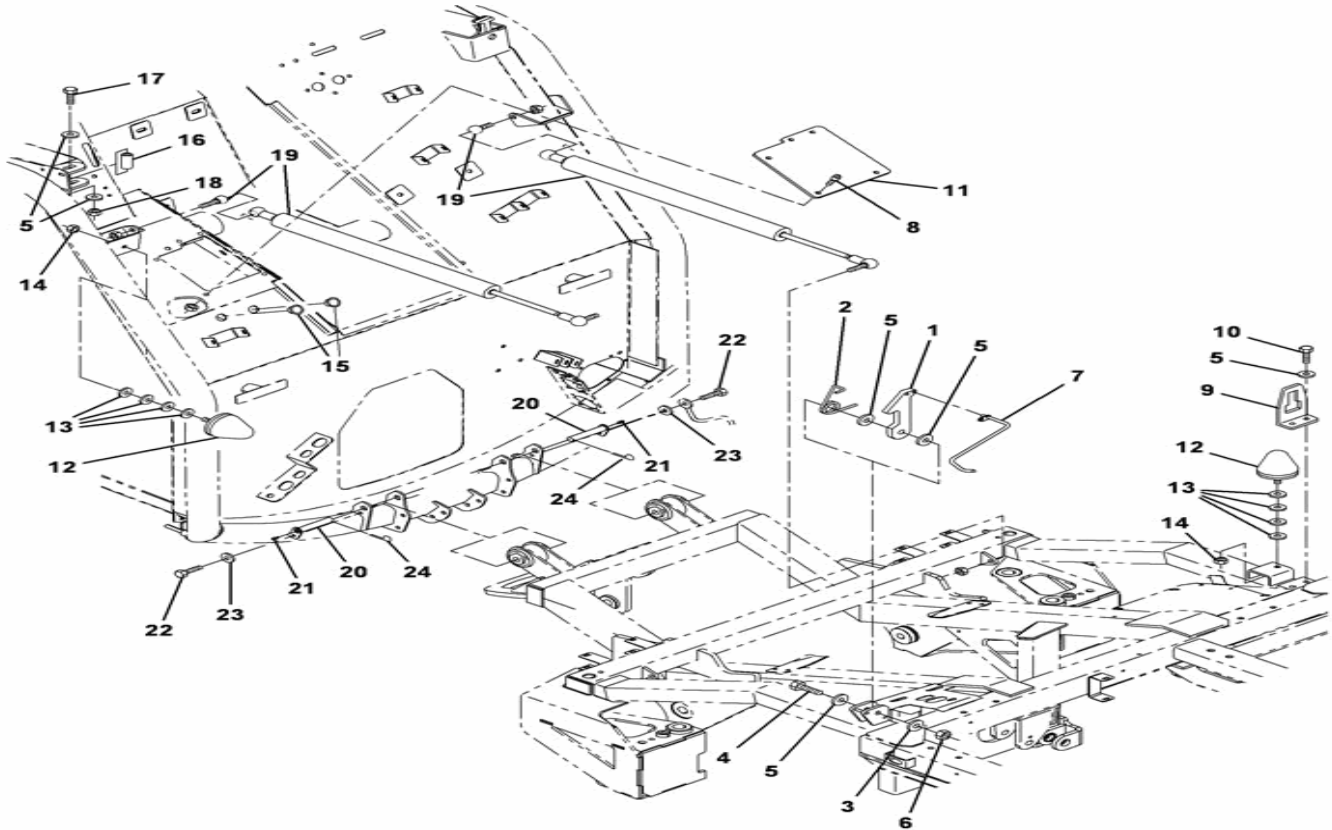

1	MC724 - Cab Lockdown Latch Left Hand	1
2	MC732 - Spring Torsion Cab Lockdown	1
3	MC730 - Collar Latch Spring	1
7	MC740 - Latch Arm Assembly	1
8	GT386 - Screw, Skt hd. M5 x 16 st st	5
9	MC727 - Cab Lockdown Bracket Right Hand	1
11	MC603 - Plate, Infill Lower Tunnel	1
12	GG233 - Conical Progressive Stop, Cab Mounti	1
13	GW021 - Washer, M8 x 25	4
14	GN004 - M8 Locknut - Nylon	1
15	GM387 - Blind Grommet -16.5 MM HOLE DIA	2
16	MC729 - Cab Lockdown Collar	1
17	GT325 - Bolt, Hex Head M10 X 70 - ST.ST A4	1
18	GN071 - Nut, nyloc - M10 ST.ST A4	1
19	GG282 - GG282 - Gas Strut,Cab Tilt	2
20	MC350 - Pivot Pin, Cab Tilt	2
21	GG039 - Grease nipple	2
24	GG177 - Pin,Split - 1/8" DIA x 1 1/4" LON	2

9a MC473 Cab Lockdown Bracket Right Hand Pre Feb/08.....1

Cab-Console

Model: **636HS Green Machine**
 From CIN: **1** To CIN: **12**
 Drawing: **636081-8** Revision:

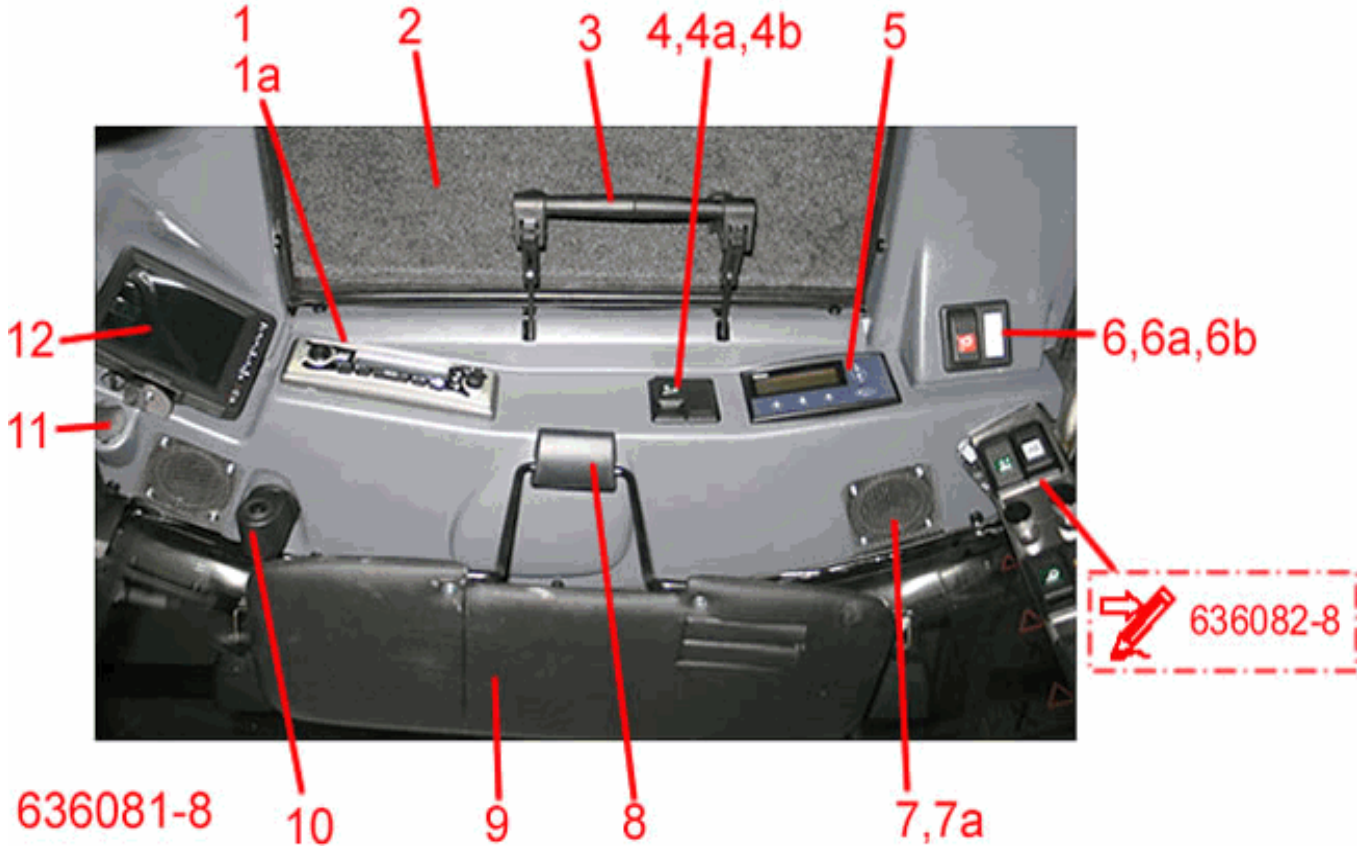

636081-8

1	ES248 - Radio/CD	1	5j	ES420 - IQAN Master Display - English/Spanish	1
1a	EC019 - Blanking Plug, radio not fitted	1	5k	ES449 - IQAN Master Display - English/Czech R	1
2	MC550 - Roof Hatch Assembly including carpet	1	5l	ES447 - IQAN Master Display - English 32 KM/H	1
3	MC272 - Hatch Stay, Double Hinge	1	5m	ES448 - IQAN Master Display - Australian/Cana	1
4	ES210 - Switch, Off/On Single Pole	1	6	ES252 - Switch Surround	2
4a	ES252 - Switch Surround	2	6a	GM466 - Legend,Hopper Drain	1
4b	GM380 - Legend, Pressure Washer	1	7	GM310 - Speaker Mesh	2
4c	ES271 - Switch Blanking Plate	1	7a	ES250 - Speaker	2
5	ES411 - IQAN Master Display - English/Spanish	1	8	MC480 - Sun Visor Cap	1
5b	ES412 - IQAN Master Display - German Language	1	9	MC479 - Sun Visor	1
5c	ES413 - IQAN Master Display - French Language	1	10	ES247 - Interior Light	1
5d	ES414 - IQAN Master Display - Portugese Langu	1	10a	ES332 - Bulb - Interior Light	1
5e	ES415 - IQAN Master Display - Italian Languag	1	11	ES272 - Power Socket	1
5e	ES415 - IQAN Master Display - Italian Languag	1	12	EC020 - Monitor, 5	1
5e	ES415 - IQAN Master Display - Italian Languag	1	12a	MC626 - Bracket, Mounting - Monitor	1
5f	ES416 - IQAN Master Display - Swedish Languag	1			
5g	ES417 - IQAN Master Display - Norwegian Langu	1			
5h	ES418 - IQAN Master Display - Dutch Language	1			
5i	ES419 - IQAN Master Display - Bulgarian Langu	1			

Cab-Controls

Model: **636HS Green Machine**
 From CIN: **1** To CIN: **12**
 Drawing: **636080-8** Revision:

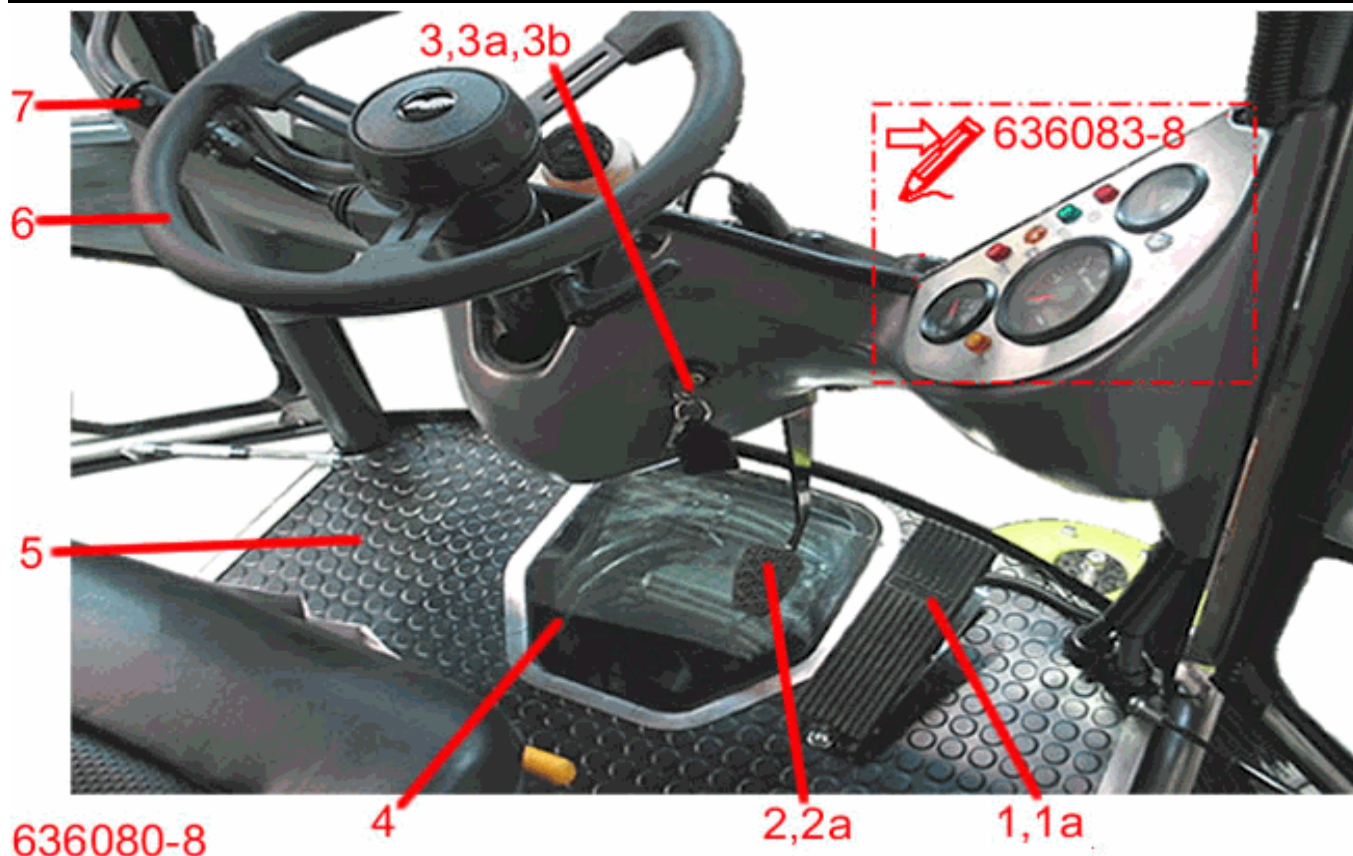

1	ES284 - Accelerator Pedal	1
1a	ES348 - Footpedal Potentiometer	1
1b	ES424 - Footpedal Potentiometer	1
2	MC050 - Brake Pedal	1
2a	BB121 - Brake Pedal Rubber	1
3	ES277 - Ignition Switch	1
3a	ES296 - Ignition key - Kubota	1
4	MC120 - Glass Floor Window	1
5	GM311 - Rubber Mat	1
6	FS015 - Steering Wheel	1
7	ES215 - Multifunction Column Switch	1

Cab-Doors

Model: **636HS Green Machine**
 From CIN: **1** To CIN: **12**
 Drawing: **636085-8** Revision:

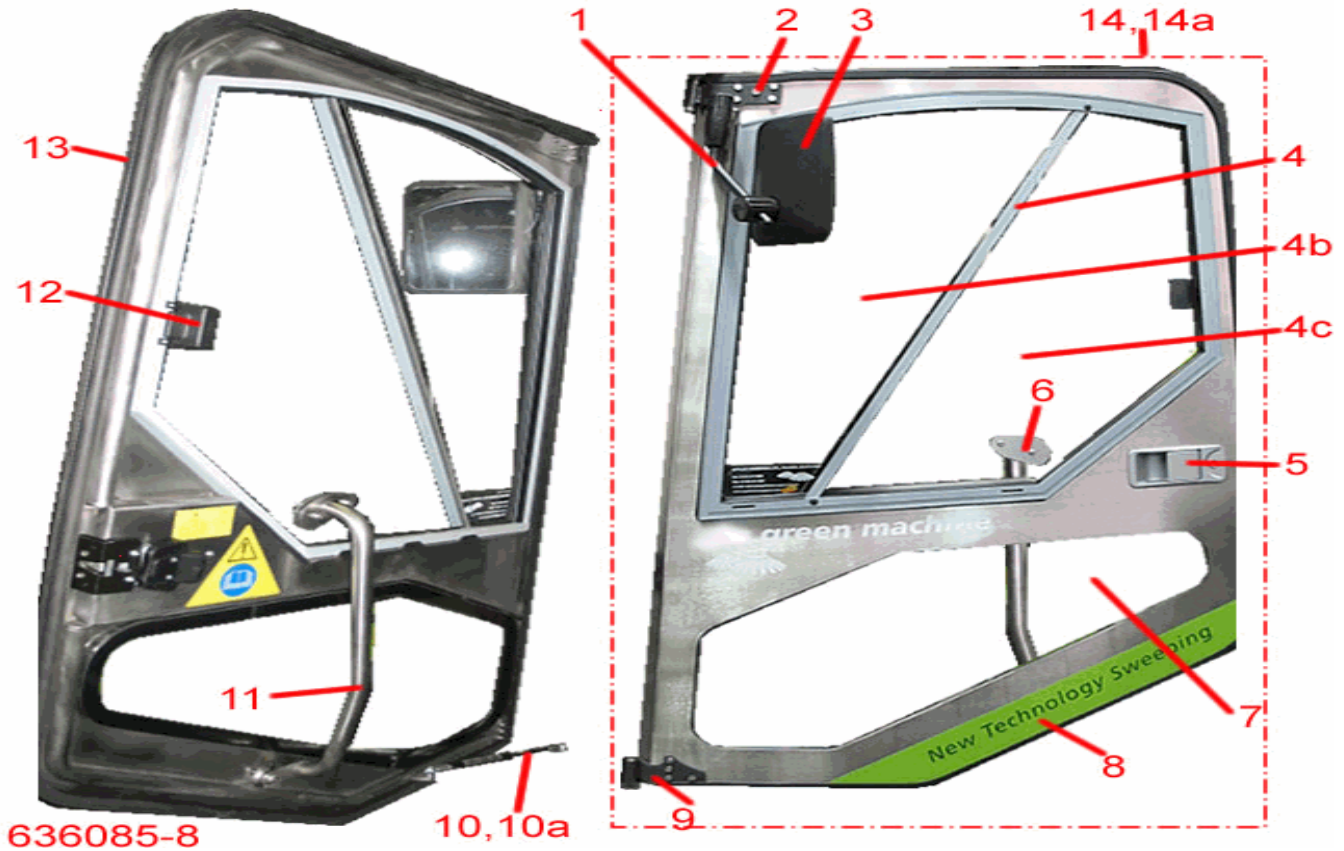

Photo Shows Left Hand Door Only

1	MC258 - Wing Mirror Arm	2	10	MC270 - Door Stay, Gas Strut Base Unit	2
2	MC150 - Hinge,Top - LH Door	1	10a	MC271 - Ball Joints, Door Stay	4
2a	MC155 - Hinge, Top - RH Door	1	11	MC249 - Pivot Arm,Window,LH	1
2b	GB060 - Bush	8	11a	MC250 - Pivot Arm,Window,RH	1
3	MC364 - Wing Mirror, Unbreakable	2	12	MC553 - Window Catch	2
4	MC121 - Window Cassette, LH	1	13	MC384 - Door Seal, Rear	2
4a	MC122 - Window Cassette, RH	1	14	MC317 - Cab Door Assembly, LH	1
4b	MC370 - Window Cassette, Fixed Glass	2	14a	MC318 - Cab Door Assembly, RH	1
4c	MC355 - Window Glass - sliding	2			
5	MC663 - Door Lock Kit - Complete (Black)	1			
5a	MC392 - Replacement Door Key	1			
6	MC405 - Outer fixing plate - for handle	2			
6a	GB110 - Sleeve, Inner - Window Fixing Pivot	4			
6b	GB109 - Isolator Bush, Outer - Window Fixing	4			
6c	GG280 - Gasket, Window Fixing Pivot	2			
7	MC118 - Fixed Glass, Lower Door	2			
9	MC163 - Hinge,Bottom,LH Door	1			
9a	MC166 - Hinge,Bottom RH Door	1			

Cab-Front

Model: **636HS Green Machine**
 From CIN: **1** To CIN: **12**
 Drawing: **636087-8** Revision:



636087-8

1	ES186 - Rotating Beacon	1
1a	ES218 - Bulb for Rotating Beacon	1
1b	GM406 - Velcro, Beacon Lock Down	1
1c	ES206 - Beacon Pivot	1
2	MC274 - Number Plate-Front	1
3	ES347 - Work Light	2
3a	ES298 - Bulb, Dipped Beam	4
4	MC582 - Heated Windscreen	1
5	ES244 - Headlamp/Indicator/Side Light (RHD)	2
5a	ES245 - Headlamp/Indicator/Side Light (LHD)	2
5b	ES217 - Bulb, Main Beam & Work Light	2
5c	ES032 - Bulb 12V 21W	2
6	MC227 - Wiper Blade, 600mm Curved	1
7	MC226 - Wiper Arm, 450mm	1
8	EC025 - Wiper Motor	1

Cab-Instrument Panel

Model: 636HS Green Machine
From CIN: 1 To CIN: 12
Drawing: 636083-8 Revision:

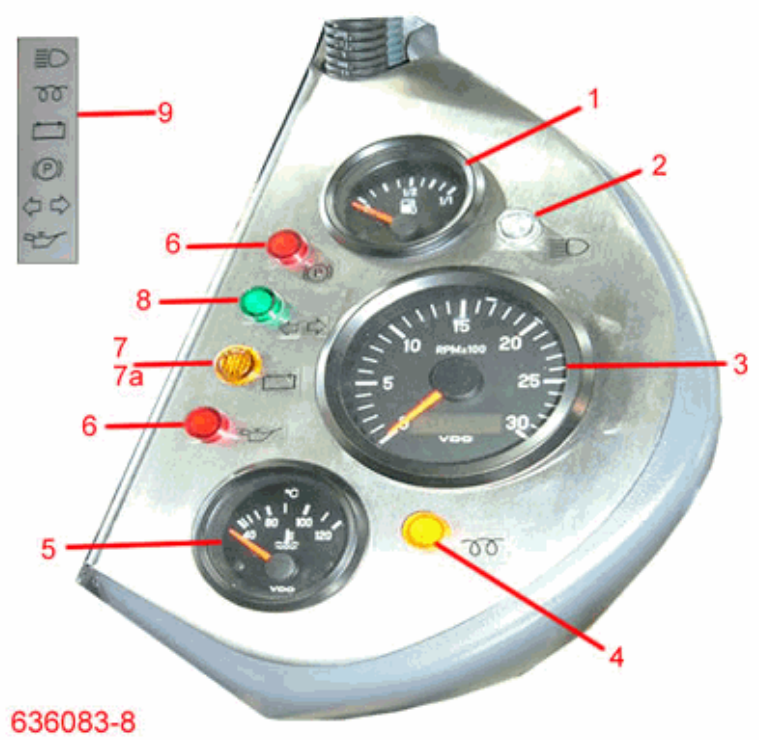

1	EH018 - Fuel Gauge	1
2	ES209 - Main Beam Warning Light (Blue)	1
3	EH025 - Tachometer c/w Hour Counter	1
4	ES017 - Warning Light - Amber	1
5	EH015 - Temperature Gauge	1
6	ES018 - Warning Light - Red	2
7	ES130 - Warning Light, Amber	1
7a	ES134 - Bulb for Turn Signal Indicator (Panel	1
8	ES192 - Warning Light (Green)	1
9	GM312 - Labels,Instrument Panel	1

Cab-Seat /Armrest Controls

Model: **636HS Green Machine**
 From CIN: **1** To CIN: **12**
 Drawing: **636084-8** Revision:

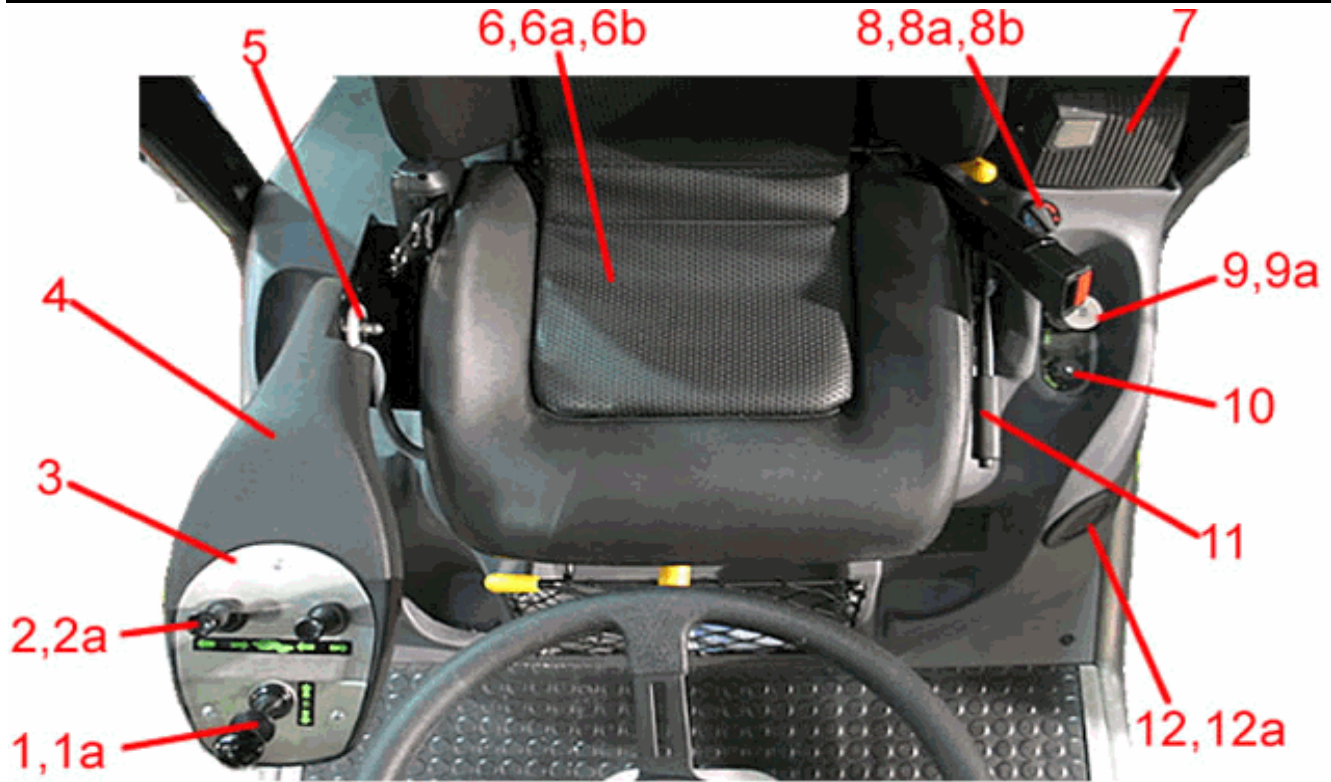

636084-8

1	ES355 - Switch, Joystick - Forward/Neutral/Re	1	11a	ES275 - Microswitch,Handbrake	1
1a	GM329 - Label-Forward,Neutral,Reverse	1	12	MC222 - Heater Outlet Vent	1
2	ES405 - Joystick - Brush Control	1	12a	MC344 - Hot Air Duct, Left Hand 300mm lg	1
2a	GM330 - Label-Brush Control	1			
3	MC378 - Facia Plate	1			
4	CP205 - Control Arm Moulding	1			
5	MC490 - Armrest Support Bracket	1			
6	MC519 - Cab Seat	1			
6a	MC225 - Lap Belt	1			
6b	MC501 - Cab Seat Wedge	1			
7	ES243 - XT2	1			
8	GG259 - Knob, Heater Control Valve	1			
8a	BB116 - Heater Control Cable	1			
8b	GM315 - Label-Temperature Increase	1			
8c	GM316 - Label-Temperature Decrease	1			
9	HV134 - Brush Pressure Valve	1			
9a	GM332 - Label-Water And Brush Pressure	1			
10	WA121 - Needle Valve	1			
11	BB118 - Hand Brake Lever	1			

Cab-Switch Panel

Model: **636HS Green Machine**
 From CIN: **1** To CIN: **12**
 Drawing: **636082-8** Revision:

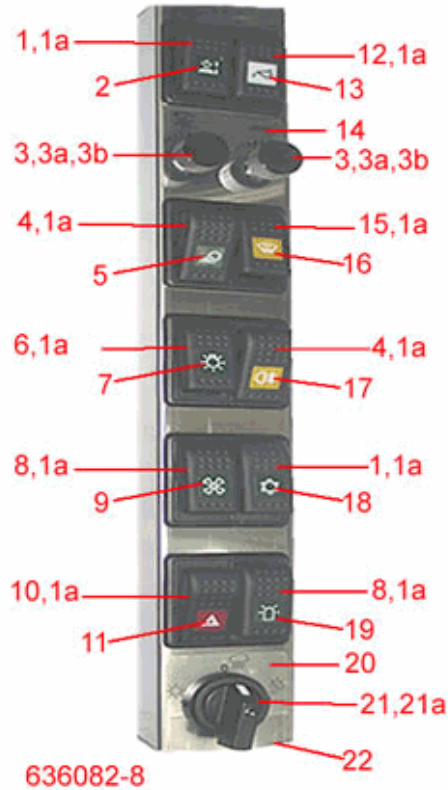

1	ES232 - Switch, Off / On double pole, double	2	16	GM251 - Legend, Windscreen Defrosting	1
1a	ES266 - Bulb & Holder	0	17	GM249 - Legend, Rear Fog Lamp	1
2	GM257 - Legend, Sweep / Transit	1	18	GM381 - Legend, Air Conditioning	1
3	ES351 - Potentiometer-Fan/Brush Speed	2	19	GM250 - Legend, Rotating Beacon	1
3a	ES352 - Knob,Fan/Brush Speed	2	20	GM448 - Label,Cloudmaker	1
3b	ES354 - Cover (potentiometer)	2	21	ES359 - Switch,Cloudmaker	1
3c	ES363 - Friction Sleeve, Speed Pots.	2	21a	ES360 - Switch,Rotary Cam	1
4	ES210 - Switch, Off/On Single Pole	2	22	MC629 - Switch Panel-Cab	1
5	GM248 - Legend, Work Light	1			
6	ES219 - Switch, Off/On/On Double Pole	1			
7	GM247 - Legend, Main Light	1			
8	ES213 - Switch, Off/On/On	2			
9	GM253 - legend, Heater Fan	1			
10	ES221 - Hazard Flasher Switch	1			
11	GM252 - Legend, Warning Lamp	1			
12	ES214 - Switch, On/Off/On Double Pole	1			
13	GM254 - Legend, Hopper Lift	1			
14	GM447 - Label,Fan and Brush Speed	1			
15	ES212 - Switch, Off/On (MOM)	1			

Brake Lines

Model: **636HS Green Machine**
 From CIN: **13** To CIN: **999**
 Drawing: **354868** Revision: **00**

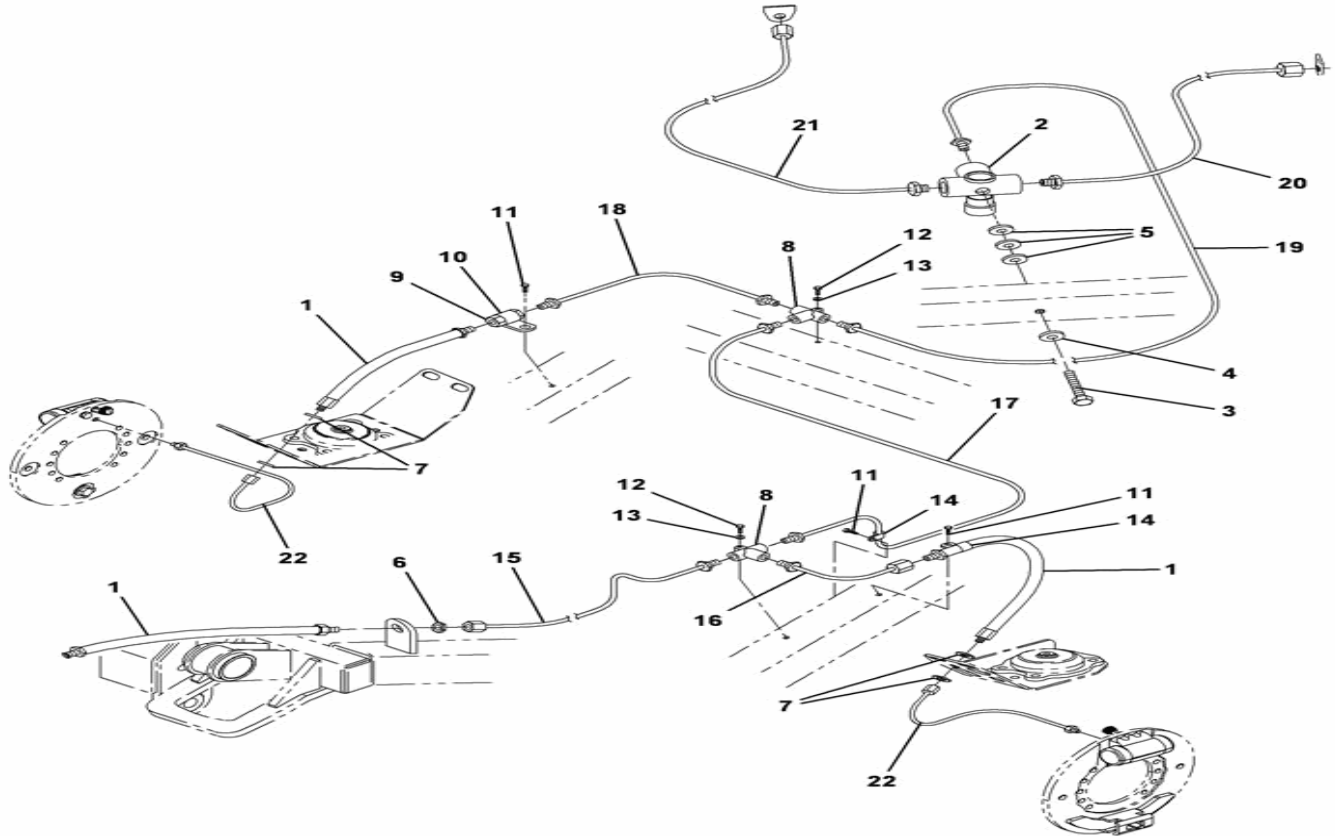

1	CT039 - Flexible Hose	3	21	BB184 - Brake Pipe - Limiter to Rear Right Ha	1
2	BB149 - Pressure Limiter - Front Brakes	1	22	BB187 - Brake Pipe, Front Right side - 636	2
3	GT318 - Bolt, Hex Head - M8 x 55	1			
4	GW015 - M8 Split Lockwasher	1			
5	GW041 - M8 Washer Form A	3			
6	GN073 - Nut,Hex Lock (Thin) M10 X 1.0P	1			
8	BB140 - Brake Pipe T-Piece	2			
9	BB146 - Brake Pipe Connector - M10 Female/Fem	1			
10	BB079 - P - Clip - ABA Rubber Lined - 13mm	1			
11	GT203 - M6 x 12 Hex Flanged Sheet Metal Screw	3			
12	GT151 - M6 x 35 Brass Setscrew	2			
13	GW029 - Washer M6 brass	2			
14	BB045 - Bracket for cable (keyhole shape)	2			
15	BB190 - Brake Pipe, T Piece to Cab - 636	1			
16	BB189 - Brake Pipe, Cab to Front Left side -	1			
17	BB188 - Brake Pipe, Centre to T-Piece Left si	1			
18	BB197 - Brake Pipe-Centre T-Peice to Right Ha	1			
19	BB186 - Brake Pipe, Rear to Centre - 636	1			
20	BB185 - Brake Pipe, Rear Left side - 636	1			

Braking System - Footbrake & Cables

Model: 636HS Green Machine
 From CIN: 1 To CIN: 12
 Drawing: 636041-8 Revision:

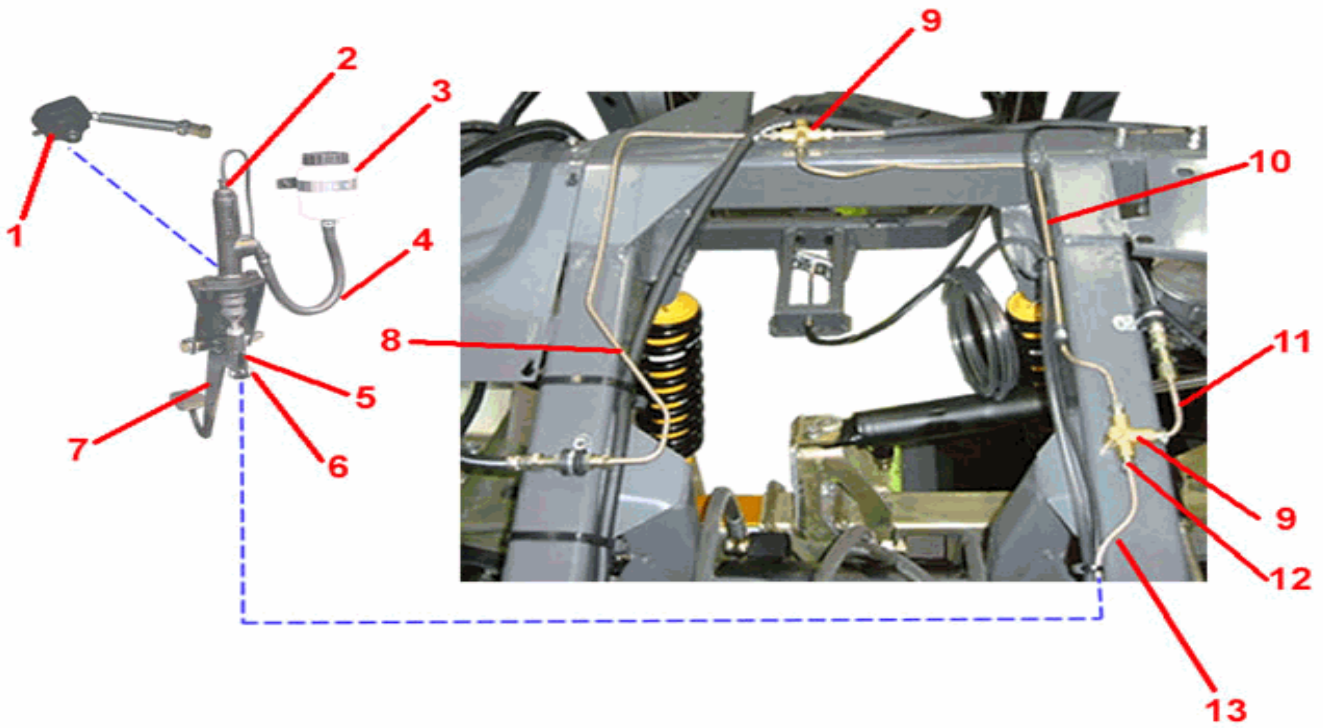

636041-8

1	ES230 - Brake Light Switch	1
2	BB148 - Master Cylinder - Footbrake - Front B	1
3	BB120 - Footbrake Reservoir	1
4	BB154 - Hose - Brake Reservoir to Master Cyli	1
5	MC062 - Clevis, Master Cylinder	1
6	MA200 - Clevis Pin	1
7	MC050 - Brake Pedal	1
8	BB187 - Brake Pipe, Front Right side - 636	1
9	BB140 - Brake Pipe T-Piece	2
10	BB188 - Brake Pipe, Centre to T-Piece Left si	1
11	BB189 - Brake Pipe, Cab to Front Left side -	1
12	BB139 - Brake Pipe Nut, Male	3
13	BB190 - Brake Pipe, T Piece to Cab - 636	1

Braking System - Front Brakes

Model: 636HS Green Machine
From CIN: 1 To CIN: 12
Drawing: 636039-8 Revision:

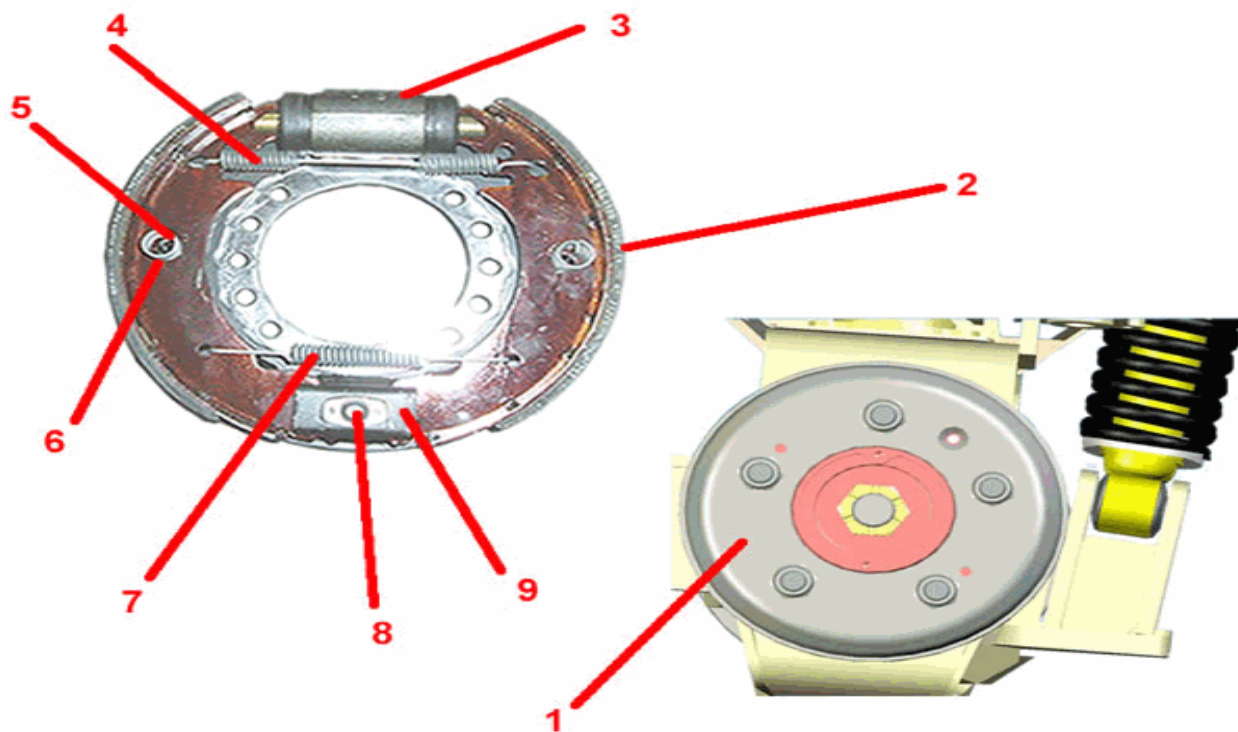

636039-8

1	FA174 - Brake Drum, Front - 636	2
2	BB177 - Brake Shoe Replacement Kit, Front	2
3	BB171 - Wheel Cylinder, Front Brake	1
4	BB179 - Tension Spring, Upper - Front Brake	1
5	BB173 - Shoe Steady Spring, Front Brake	2
6	BB176 - Spring Buckle, Front Brake	2
7	BB178 - Tension Spring, Lower - Front Brake	1
8	BB174 - Adjuster Bolt, Front Brake	1
9	BB175 - Adjuster Wedge, Front Brakes	1

Braking System - Handbrake & Cables

Model: 636HS Green Machine
 From CIN: 1 To CIN: 12
 Drawing: 636042-8 Revision:

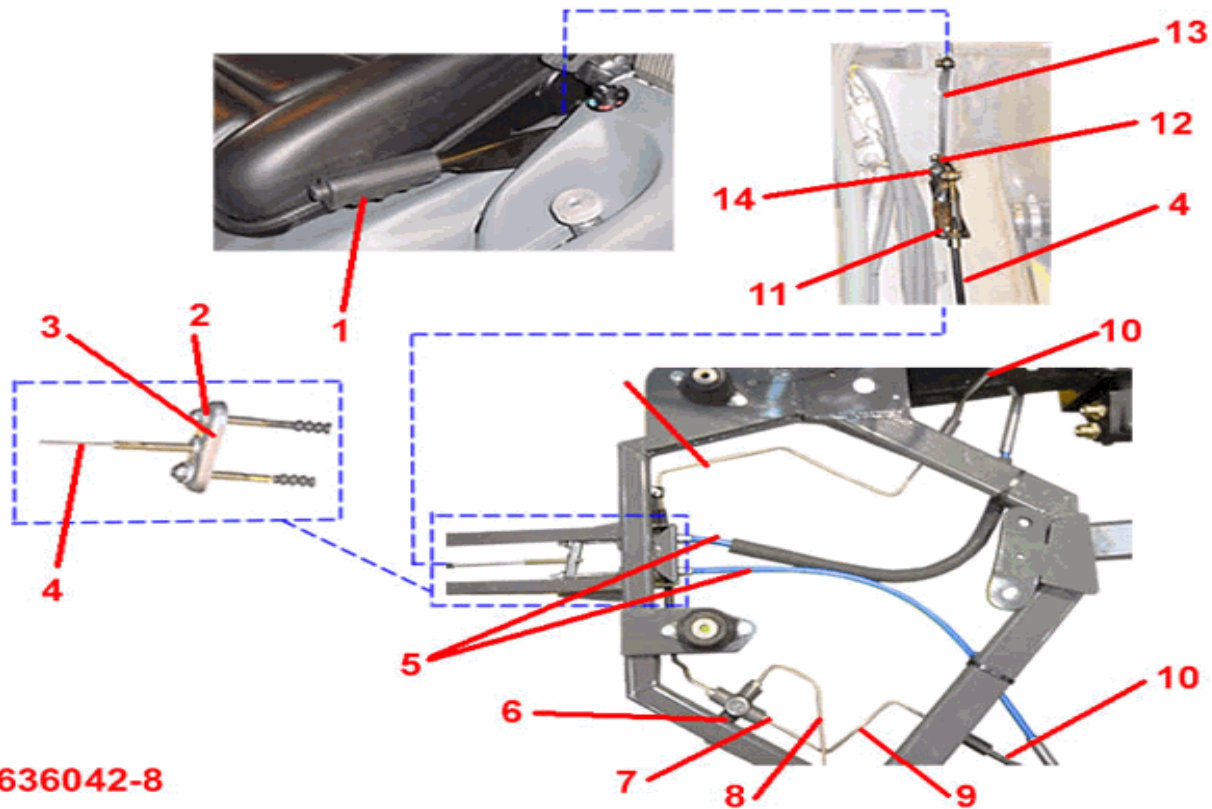

636042-8

1	BB118 - Hand Brake Lever	1
2	GW081 - Cup Washer	2
3	BB132 - Brake Cable Balance Bar	1
4	BB129 - Brake Cable, Front	1
5	BB182 - Brake Cable, Rear - 636	2
6	BB149 - Pressure Limiter - Front Brakes	1
7	BB150 - Brake Pipe Nut - Male - M12	3
8	BB186 - Brake Pipe, Rear to Centre - 636	1
9	BB185 - Brake Pipe, Rear Left side - 636	1
10	CT039 - Flexible Hose	5
11	CC219 - Clevis Pin.	1
12	MC309 - Handbrake Bellcrank Weldment	1
13	MC312 - Tie Rod, machined, Handbrake Bellcran	1
13	MC312 - Tie Rod, machined, Handbrake Bellcran	1
14	MC298 - Handbrake Pivot Bracket Weldment	1
15	BB138 - Brake Pipe Nut, Female	2

Braking System - Rear Brakes

Model: 636HS Green Machine
From CIN: 1 To CIN: 12
Drawing: 636040-8 Revision:

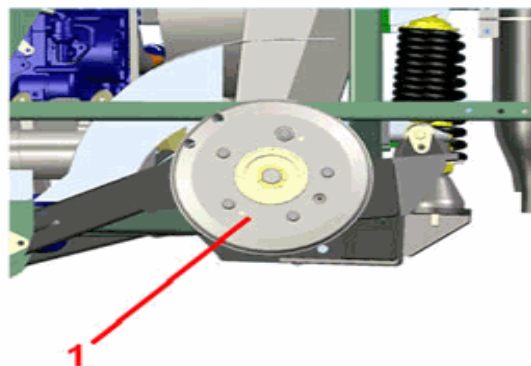
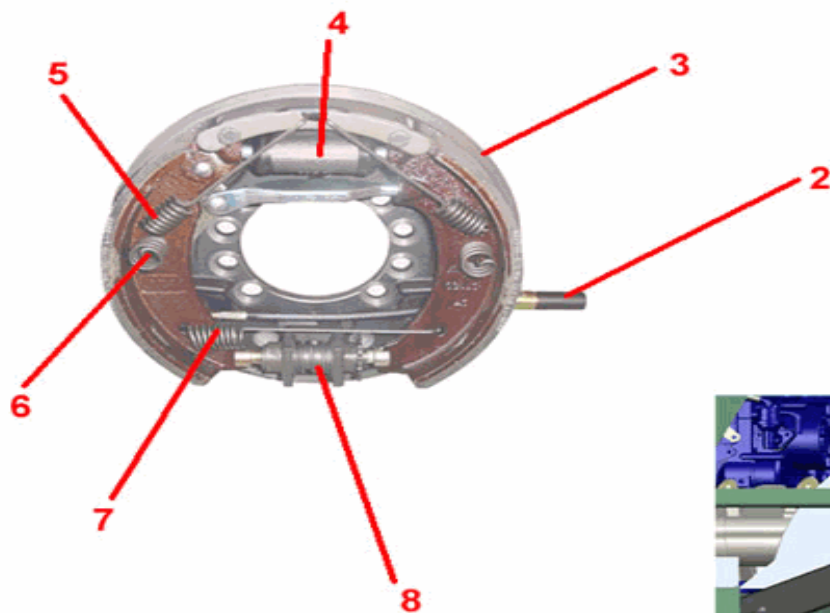

636040-8

1	CT056 - Rear Brake Drum - 636	2
2	BB125 - Brake Cable Adaptor	2
3	BB126 - Brake Shoe Replacement Kit	1
4	BB133 - Wheel Cylinder	2
5	BB135 - Brake, Upper Tension Spring	4
6	BB134 - Brake Shoe Steady Spring	4
7	BB136 - Lower Tension Spring	2
8	BB127 - Manual Adjuster	2

Front Axle

Model: **636HS Green Machine**
 From CIN: **13** To CIN: **999**
 Drawing: **354825** Revision: **00**

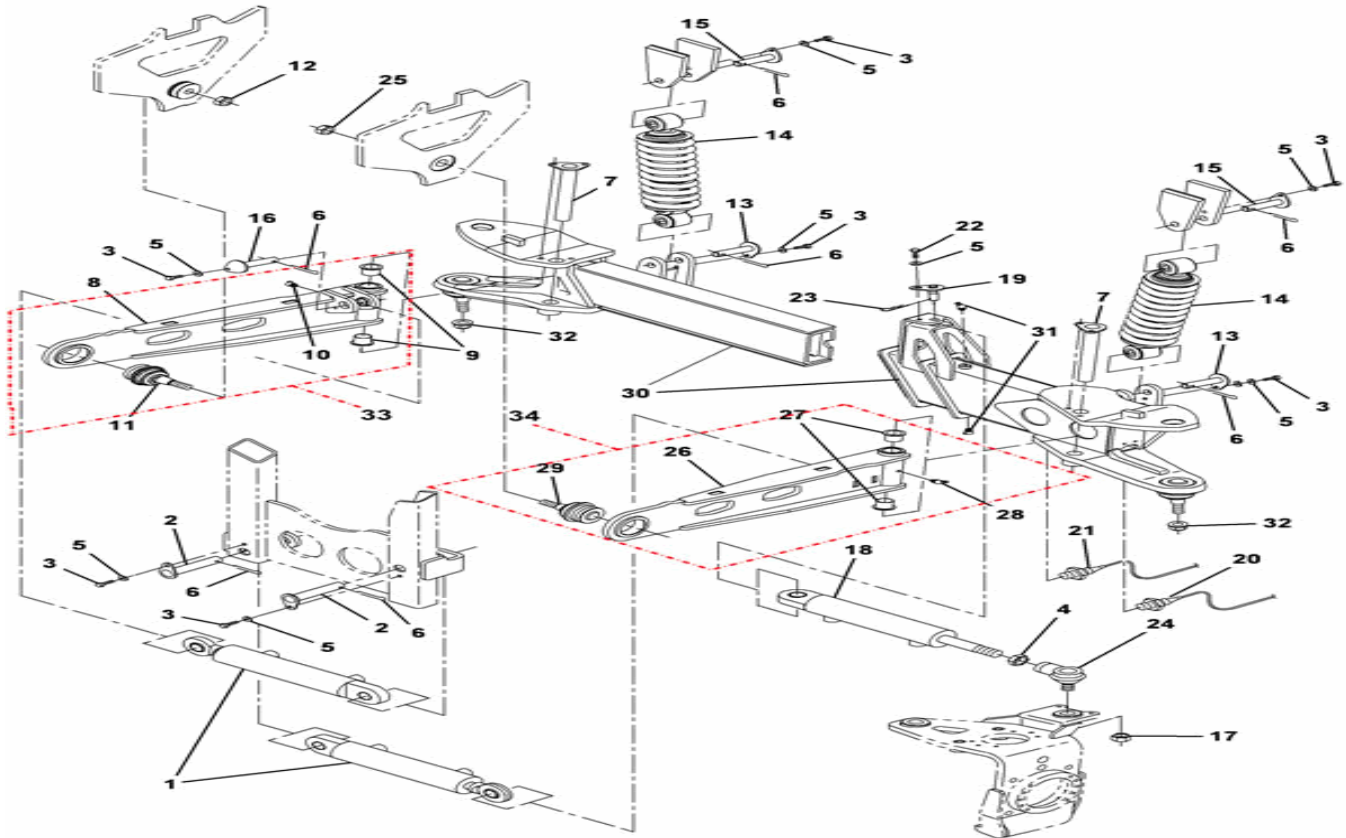

1	HC198 - Hydraulic Cylinder - Tracking	2	24	GG229 - Ball Joint, Track Rod/Drag Link End	1
2	FA127 - Pivot Pin, Tracking Cylinder Anchor	2	26	FA083 - Trailing Arm, Left Hand	1
4	GN064 - Nut Hex Lock Thin - M16 x 1.5P	1	27	GB073 - DU Flanged Bush 20 id x 23 od x 22 l	2
6	GG265 - Pin, Split 4.0 x 25 ST.ST	8	28	GG023 - Grease Nipple 45 degree - 6mm	1
7	FA085 - Pivot Pin, Trailing Arm	2	29	GG227 - Ball Joint	1
8	FA073 - Trailing Arm, Right Hand	1	30	FA151 - Axle Assy c/w lower ball joints	1
9	GB073 - DU Flanged Bush 20 id x 23 od x 22 l	2	31	GG039 - Grease nipple	2
10	GG023 - Grease Nipple 45 degree - 6mm	1	33	FA072 - Trailing Arm Assy R.H inc ball joint	1
11	GG227 - Ball Joint	1	34	FA082 - Trailing Arm Assy L.H. inc ball join	1
13	FA130 - Pivot Pin, Front Shock Absorber Lower	2			
14	CT053 - Shock Absorber Assembly (Yellow Sprin	2			
15	CT025 - Pivot Pin	2			
16	FA123 - Pivot Pin, Tracking Cylinder	2			
17	GN091 - Nut, Stover - M16 x 1.5P	1			
18	HC137 - Hydraulic Cylinder - Steering	1			
19	FA069 - Pivot Pin, Steering Cylinder	1			
20	ES280 - Tracking Sensor, IN	1			
21	ES281 - Tracking Sensor, OUT	1			
23	BB028 - R Pin	1			

Front Axle & Steering Linkage

Model: **636HS Green Machine**
 From CIN: 1 To CIN: 12
 Drawing: **636086-8** Revision:

636086-8

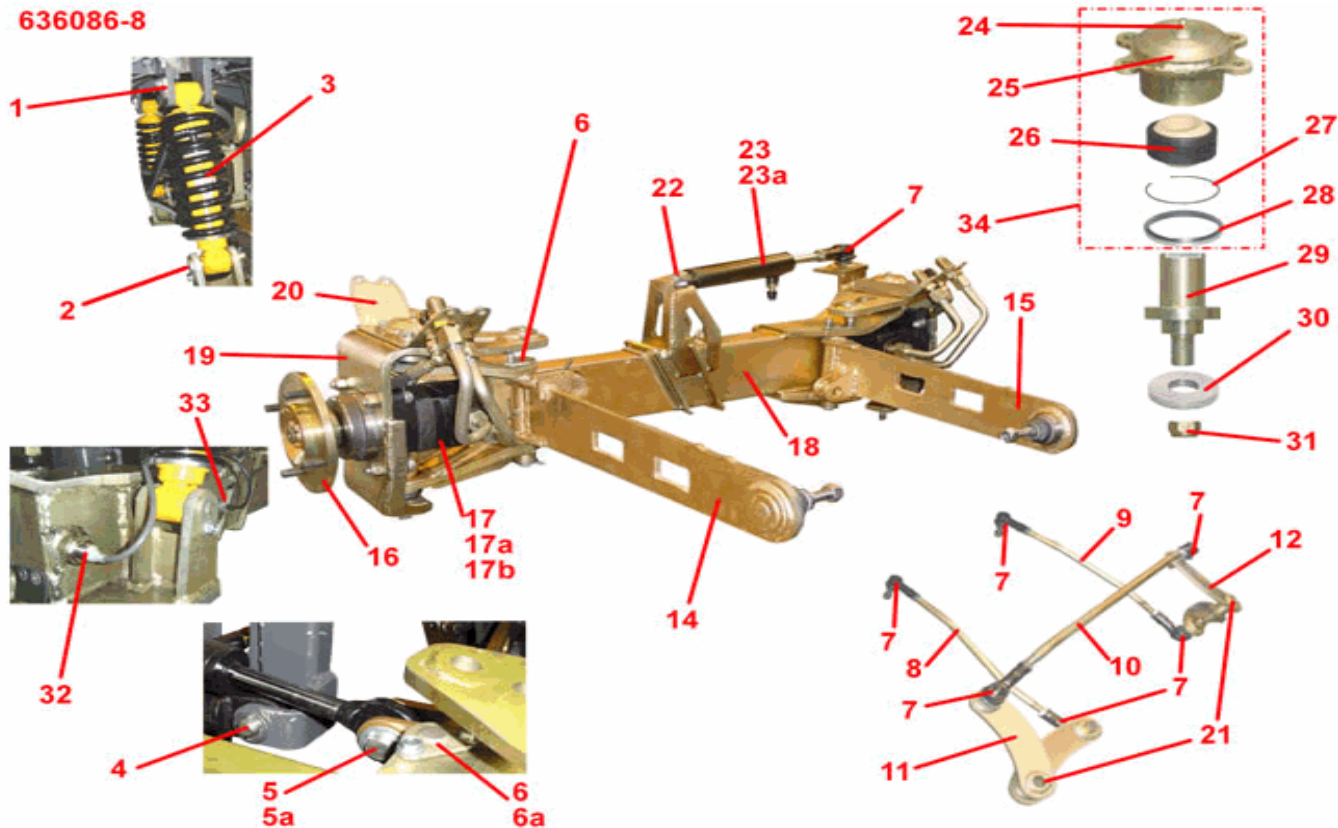

1	CT025 - Pivot Pin	2	17a	HM031 - Key, Wheel Motor	2
2	FA130 - Pivot Pin, Front Shock Absorber Lower	2	17b	HM033 - Seal Kit, Wheel Motor	1
3	CT053 - Shock Absorber Assembly (Yellow Sprin	2	18	FA151 - Axle Assy c/w lower ball joints	1
4	FA127 - Pivot Pin, Tracking Cylinder Anchor	2	19	FA155 - Hub Carrier, LH	1
5	FA123 - Pivot Pin, Tracking Cylinder	2	19a	FA156 - Hub Carrier, RH	1
5a	FA129 - Spacer for Tracking Cylinder	2	20	FA117 - Bulkhead, RH Transmission	1
6	FA085 - Pivot Pin, Trailing Arm	2	21	FA089 - Pivot Pin, Bell Crank	2
6a	GB091 - Bushes for Brush Arms	8	22	FA069 - Pivot Pin, Steering Cylinder	1
7	GG229 - Ball Joint, Track Rod/Drag Link End	7	23	HC137 - Hydraulic Cylinder - Steering	1
8	FS016 - Drag Link Assy. R.H. inc ball joint	1	23a	HC139 - Seal Kit, Steering Cylinder	1
9	FS007 - Drag Link Assy. L.H. inc ball joint	1	24	GG039 - Grease nipple	2
10	FS010 - Track Rod Assembly	1	25	FA064 - Bearing Housing, Top King Pin	2
11	FS001 - Bell Crank Steering Lever R.H. assy	1	26	GG244 - Spherical Bearing, 30 i/d x 55	2
12	FS005 - Bell Crank Steering Lever L.H. assy	1	27	GM260 - Snap Ring, Internal 55mm bore	2
14	FA072 - Trailing Arm Assy R.H. inc ball joint	1	28	HC163 - Scraper 56 o/d x 50 i/d x 7mm	2
15	FA082 - Trailing Arm Assy L.H. inc ball joint	1	29	FA093 - Pivot Pin, Top Kingpin	2
16	FA175 - Wheel Hub Assembly, Front c/w Studs -	2	30	FA134 - Washer, Top Kingpin	2
16a	GT392 - Wheel Stud, M16 x 1.5 x 45 - 636	0	31	GN091 - Nut, Stover - M16 x 1.5P	2
17	HM035 - Wheel Motor, 100cc	2	32	ES280 - Tracking Sensor, IN	1

Front Axle & Steering Linkage

Model: 636HS Green Machine
 From CIN: 1 To CIN: 12
 Drawing: 636086-8 Revision:

636086-8

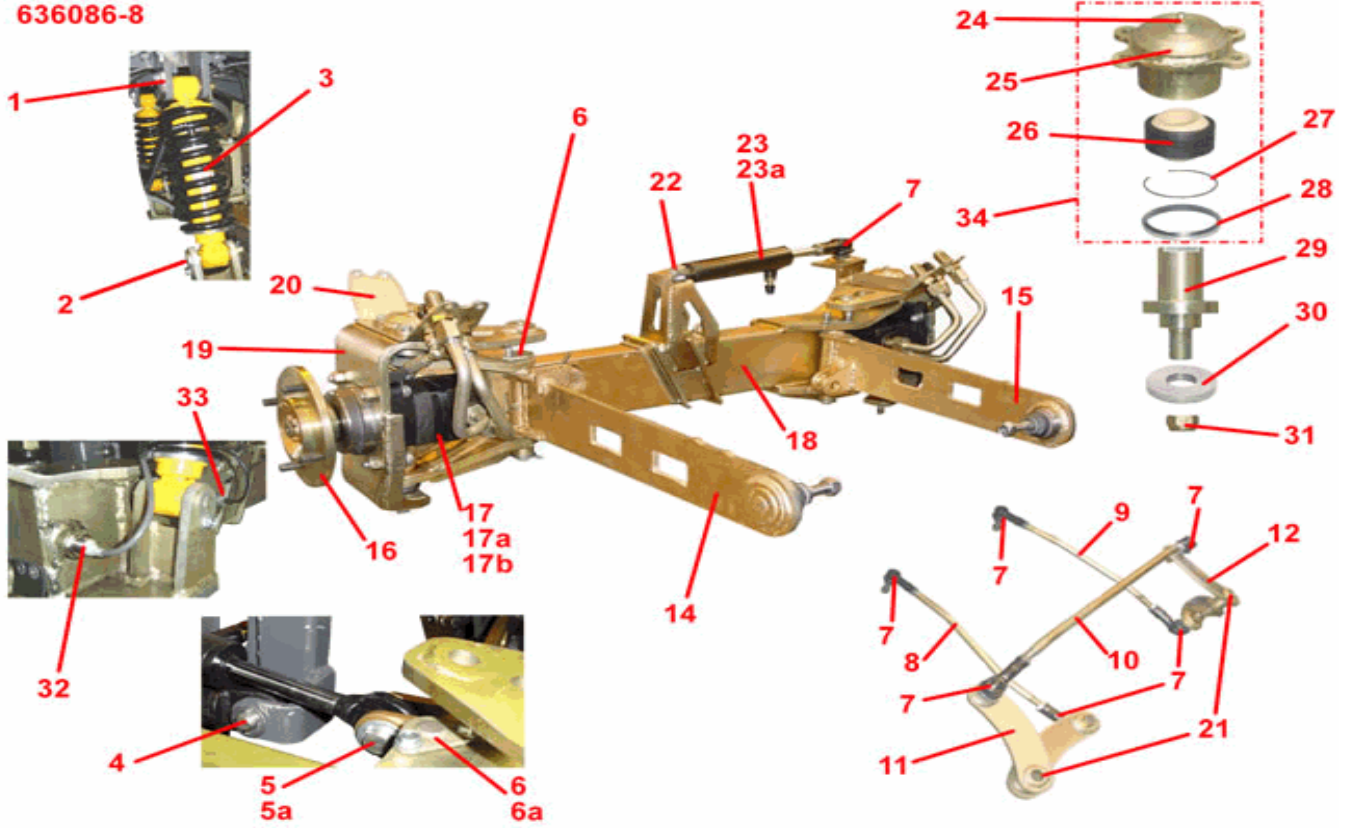

33	ES281 - Tracking Sensor, OUT	1
34	FA176 - Bearing Housing Assembly, Top King Pi	2

Front Drive Wheel Motor - Left Hand

Model: 636HS Green Machine
 From CIN: 13 To CIN: 999
 Drawing: 354821 Revision: 00

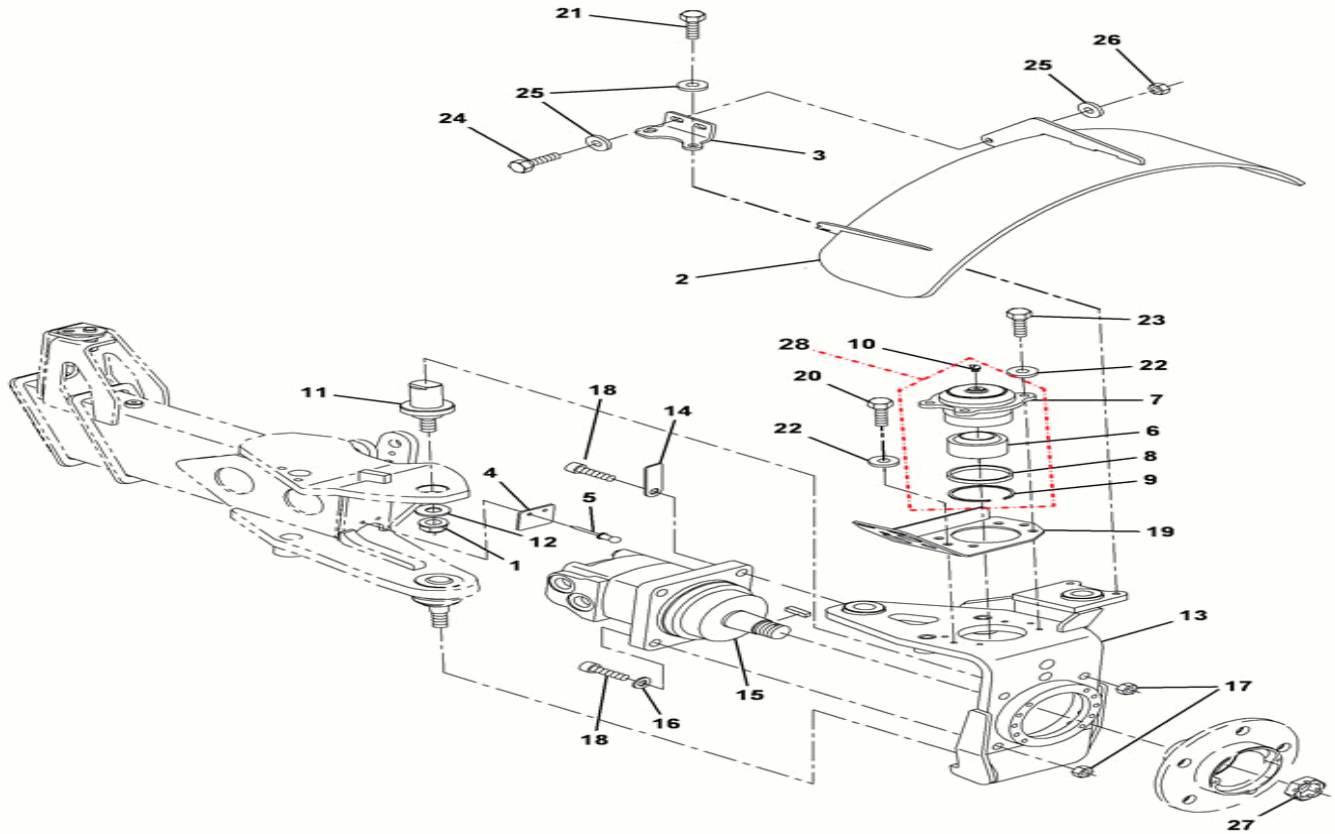

1	GN091 - Nut, Stover - M16 x 1.5P	1
2	CB878 - Mudguard, Left Hand	1
3	CD007 - Plate, Fixing - Left Hand Mudguard	1
4	FA171 - End Cover, Axle Beam	1
5	GG134 - Pop Rivets - 3/16' Large Flange	2
6	GG244 - Spherical Bearing, 30 i/d x 55	1
7	FA064 - Bearing Housing, Top King Pin	1
8	HC163 - Scraper 56 o/d x 50 i/d x 7mm	1
9	GM260 - Snap Ring, Internal 55mm bore	1
10	GG023 - Grease Nipple 45 degree - 6mm	1
11	FA093 - Pivot Pin, Top Kingpin	1
12	FA134 - Washer, Top Kingpin	1
13	FA155 - Hub Carrier, LH	1
14	FA116 - Plate, Support - Case Drain Hose - De	2
15	HM057 - Motor Wheel - 130CC Rev Displacement	1
18	GT293 - Screw, Socket Head Cap - M12 x 50 - G	4
19	FA119 - Bulkhead, LH Transmission	1
27	HM032 - Nut, Rear Wheel Drive Motors	1
28	FA176 - Bearing Housing Assembly, Top King Pi	1

Front Drive Wheel Motor - Right Hand

Model: 636HS Green Machine
 From CIN: 13 To CIN: 999
 Drawing: 354822 Revision: 00

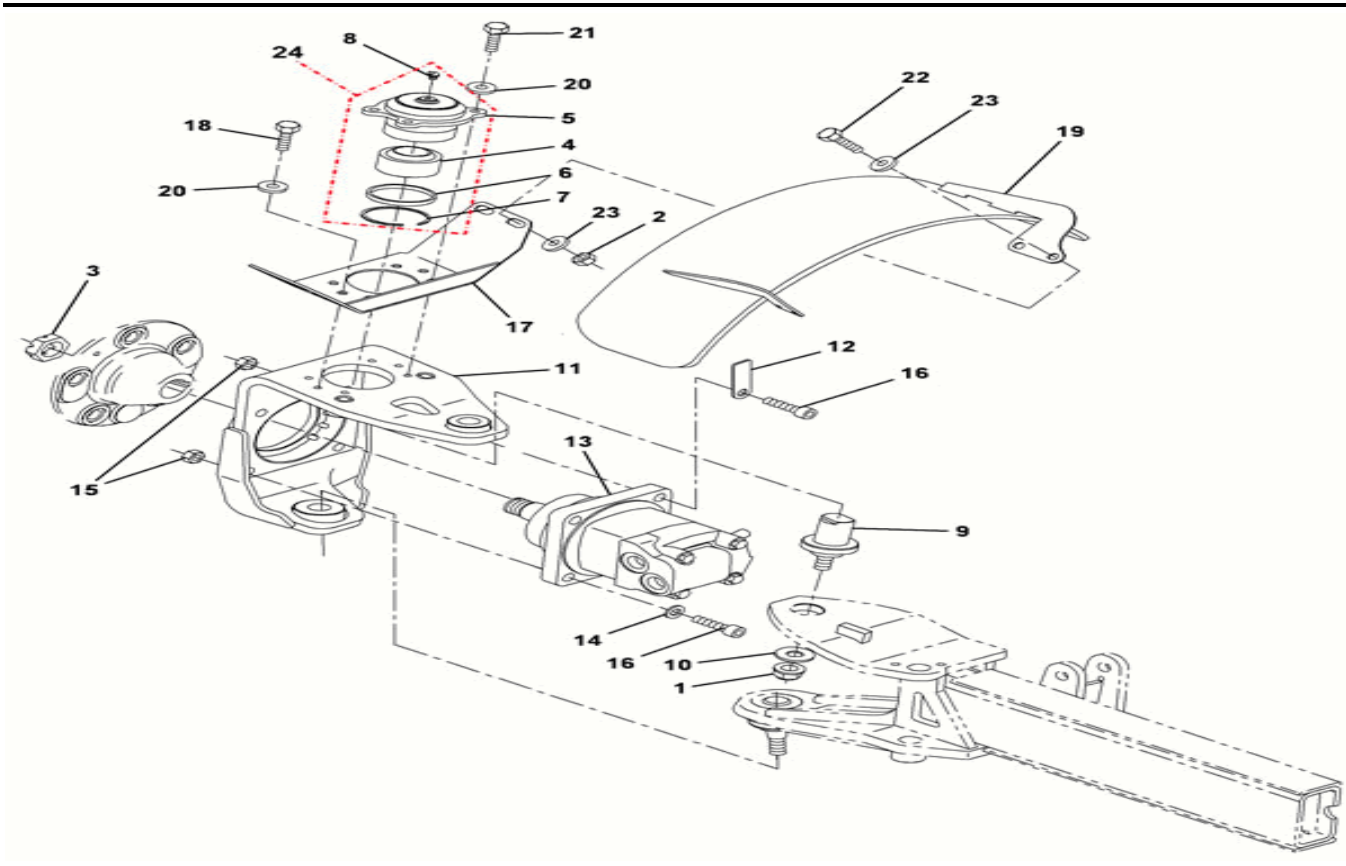

1	GN091 - Nut, Stover - M16 x 1.5P	1
3	HM032 - Nut, Rear Wheel Drive Motors	1
4	GG244 - Spherical Bearing, 30 i/d x 55	1
5	FA064 - Bearing Housing, Top King Pin	1
6	HC163 - Scraper 56 o/d x 50 i/d x 7mm	1
7	GM260 - Snap Ring, Internal 55mm bore	1
8	GG023 - Grease Nipple 45 degree - 6mm	1
9	FA093 - Pivot Pin, Top Kingpin	1
10	FA134 - Washer, Top Kingpin	1
11	FA156 - Hub Carrier, RH	1
12	FA116 - Plate, Support - Case Drain Hose - De	2
13	HM057 - Motor Wheel - 130CC Rev Displacement	1
16	GT293 - Screw, Socket Head Cap - M12 x 50 - G	4
17	FA117 - Bulkhead, RH Transmission	1
19	CB890 - Mudguard, Right Hand	1
24	FA176 - Bearing Housing Assembly, Top King Pi	1

Main Chassis

Model: **636HS Green Machine**
 From CIN: **13** To CIN: **999**
 Drawing: **354867** Revision: **00**

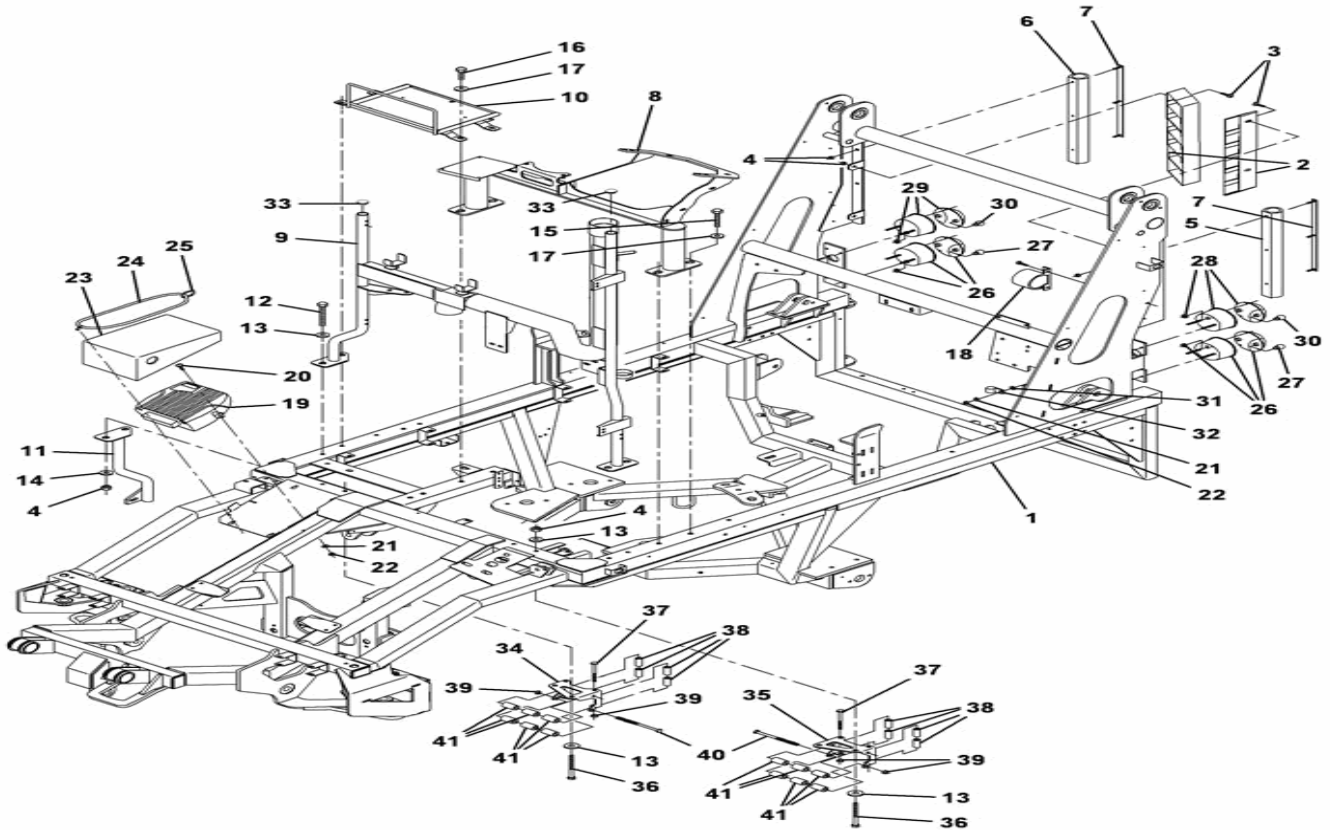

1	CA364 - Chassis Weldment	1	29	ES255 - Indicator / Fog Lamp	1
2	CD290 - Louvre Weldment	2	30	ES032 - Bulb 12V 21W	4
5	GM294 - GM294 - Bumper,Rear Left Hand	1	34	CB855 - Bracket, Transmission Hose Guide Right	1
6	GM463 - GM463 - Bumper,Rear Right Hand	1	35	CB850 - Bracket, Transmission Hose Guide Left	1
7	CD055 - Fixing Bracket Assembly, Rubber Bumper	2	36	GT377 - Bolt Hex Head M8 x 75 ST.ST A4	2
8	CD170 - Support Frame Inlet Tube	1	37	GT312 - Bolt Hex Head - M6 x 70 ST.ST A4	4
9	PP403 - Air intake Goalpost Weldment	1	38	GB095 - Boss 16 od x 8.5 id x 28 lg	8
10	CD090 - Battery Tray Weldment	1	39	GN046 - Nut Nyloc Thin M6	8
11	CD083 - Bracket, Right Hand Side Panel	1	40	GT313 - Bolt Hex Head - M6 x 100 ST.ST A4	4
16	GT325 - Bolt, Hex Head M10 X 70 - ST.ST A4	2	41	GB090 - Roller,Nylon-28mm long	2
18	ES038 - Audible Beeper - Horn	1			
19	ES243 - XT2	1			
20	GT111 - M6 x 20 Button Head Screw	2			
23	CP223 - Plastic Cover - XT2 Unit	1			
24	AW009 - Rubber fastener for whoosh hose	1			
25	GM154 - Snap Clip	1			
26	ES254 - Rear / Brake Lamp	2			
27	ES276 - Bulb for ES254	2			
28	ES256 - Indicator / Reverse Lamp	1			

Rear Trailing Arm - Left Hand

Model: 636HS Green Machine
 From CIN: 13 To CIN: 999
 Drawing: 354817 Revision: 00

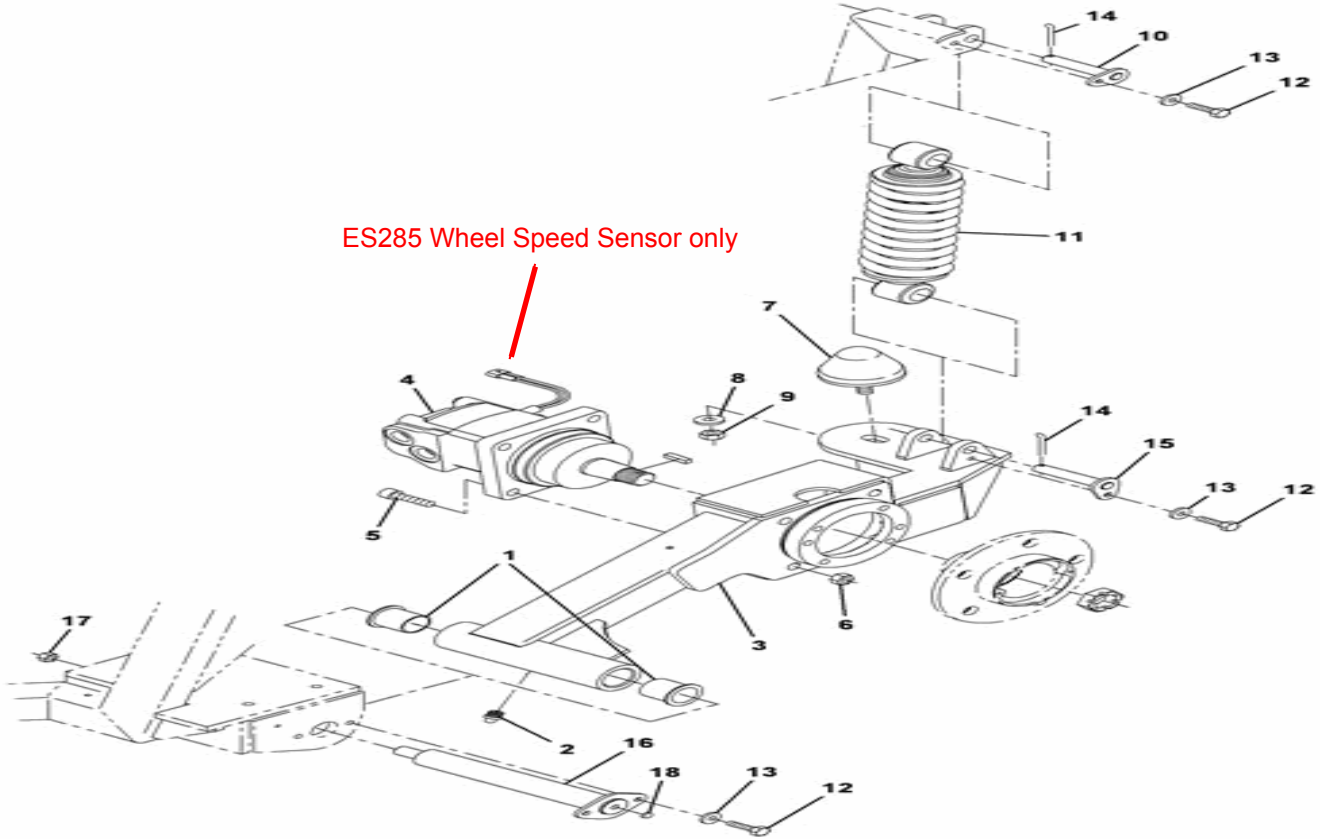

1	GB089 - Bush, 30 i/d x 34 o/d x 37 lg	2
2	GG039 - Grease nipple	1
3	CT019 - Rear Axle L.H.	1
4	HM058 - Motor, Wheel - 130CC - C/W Speed Sens	1
5	GT376 - Screw - Cap SKT HD - M12 x 45 - ZN PT	4
7	GG234 - Conical Stop 72mm o/d x 58mm	1
10	CT025 - Pivot Pin	1
11	CT053 - Shock Absorber Assembly (Yellow Sprin	1
14	GG265 - Pin, Split 4.0 x 25 ST.ST	2
15	FA130 - Pivot Pin, Front Shock Absorber Lower	1
16	CT021 - Pivot Pin, Rear Axle	1
17	GN068 - M16 Nylon Nut	1
18	GG260 - Locking Pin Spring	1

Rear Trailing Arm - Right Hand

Model: 636HS Green Machine
 From CIN: 13 To CIN: 999
 Drawing: 354818 Revision: 00

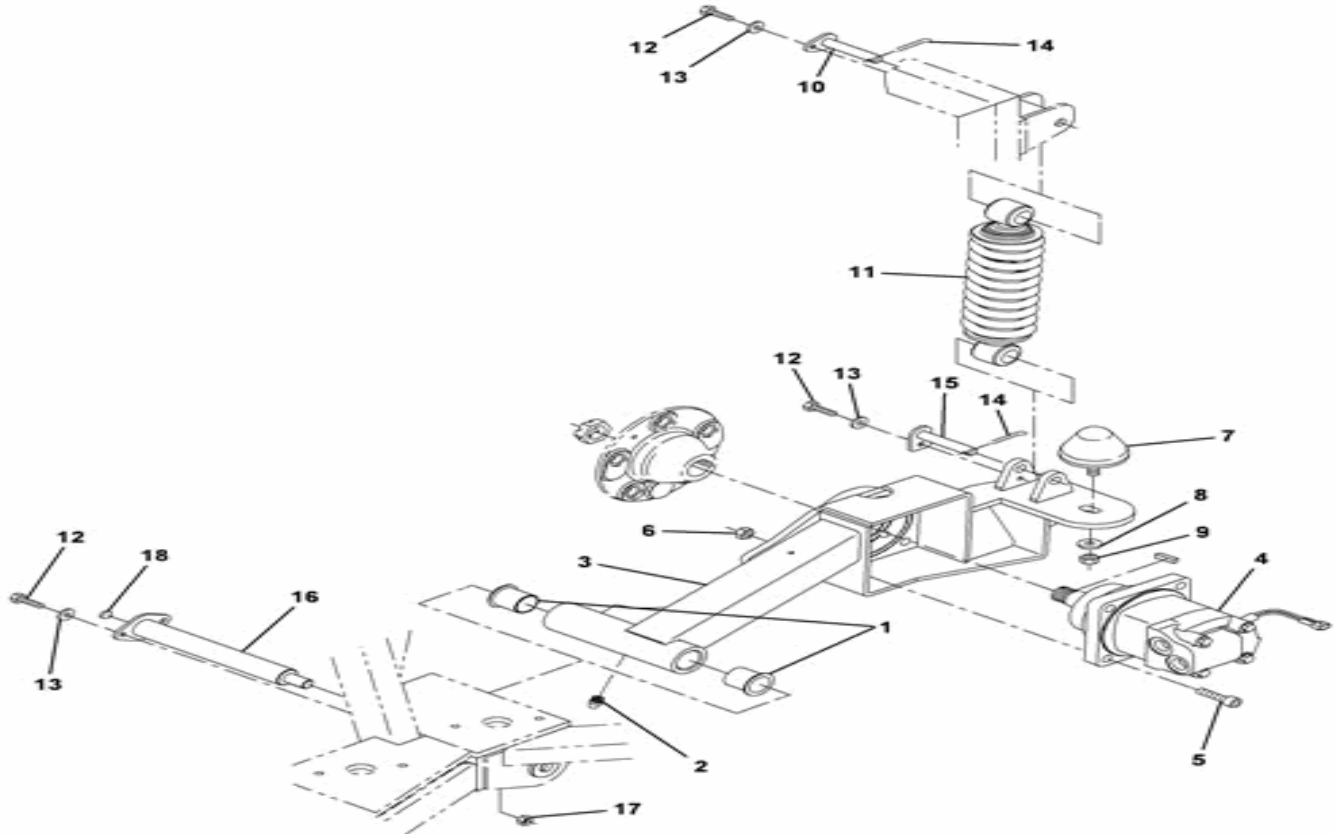

1	GB089 - Bush, 30 i/d x 34 o/d x 37 lg	2
2	GG039 - Grease nipple	1
3	CT002 - Rear Axle R.H.	1
5	GT376 - Screw - Cap SKT HD - M12 x 45 - ZN PT	4
7	GG234 - Conical Stop 72mm o/d x 58mm	1
10	CT025 - Pivot Pin	1
11	CT053 - Shock Absorber Assembly (Yellow Sprin	1
14	GG265 - Pin, Split 4.0 x 25 ST.ST	2
15	FA130 - Pivot Pin, Front Shock Absorber Lower	1
16	CT021 - Pivot Pin, Rear Axle	1
17	GN068 - M16 Nylon Nut	1
18	GG260 - Locking Pin Spring	1

Steering Linkage

Model: **636HS Green Machine**
 From CIN: **13** To CIN: **999**
 Drawing: **354824** Revision: **00**

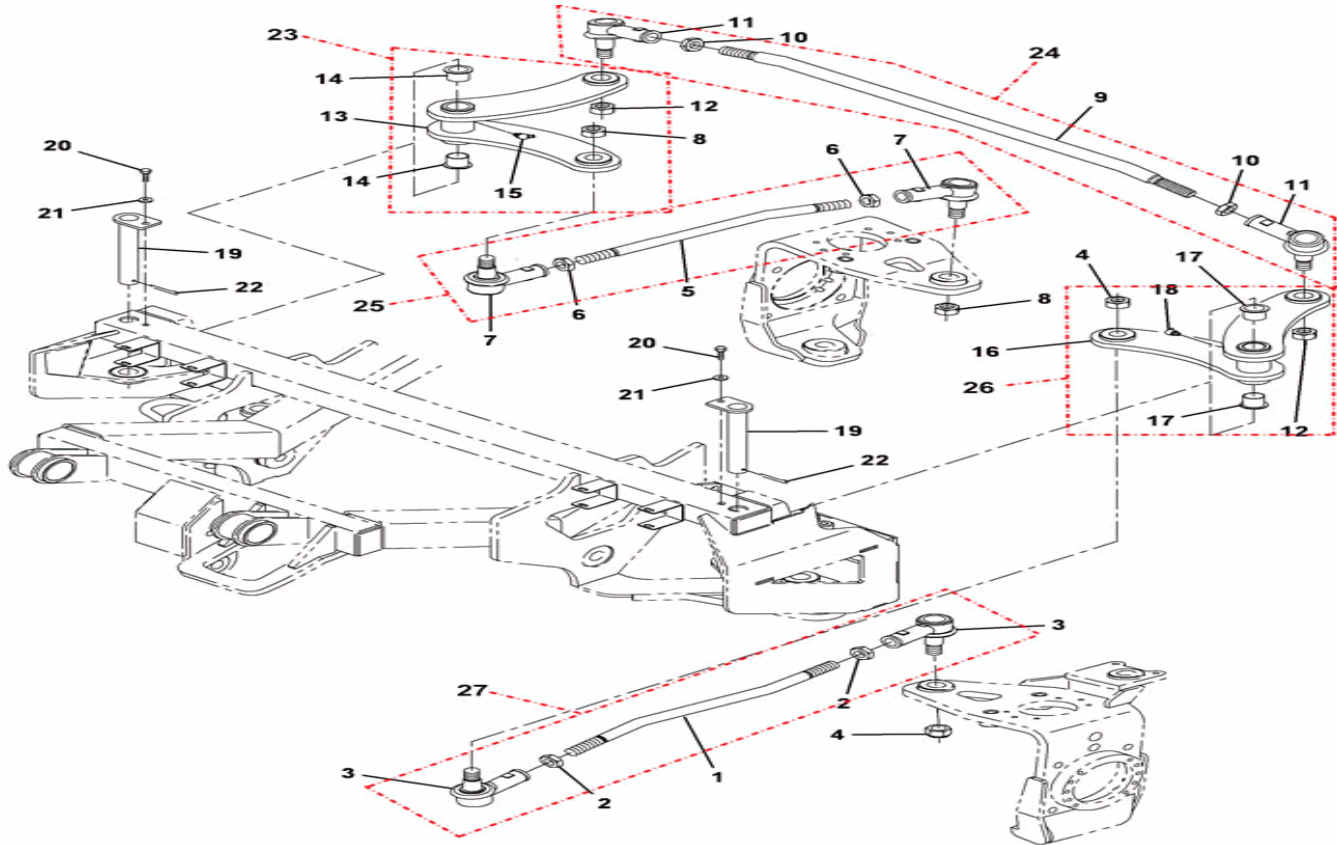

1	FS008 - Drag Link LH	1	22	GG265 - Pin, Split 4.0 x 25 ST.ST	2
2	GN064 - Nut Hex Lock Thin - M16 x 1.5P	2	23	FS001 - Bell Crank Steering Lever R.H. assy	1
3	GG229 - Ball Joint, Track Rod/Drag Link End	2	24	FS010 - Track Rod Assembly	1
4	GN091 - Nut, Stover - M16 x 1.5P	2	25	FS016 - Drag Link Assy. R.H. inc ball joint	1
5	FS017 - Drag Link - Right Hand	1	26	FS005 - Bell Crank Steering Lever L.H. assy	1
6	GN064 - Nut Hex Lock Thin - M16 x 1.5P	2	27	FS007 - Drag Link Assy. L.H. inc ball join	1
7	GG229 - Ball Joint, Track Rod/Drag Link End	2			
8	GN091 - Nut, Stover - M16 x 1.5P	2			
9	FS012 - Track Rod Tube	1			
10	GN064 - Nut Hex Lock Thin - M16 x 1.5P	2			
11	GG229 - Ball Joint, Track Rod/Drag Link End	2			
12	GN091 - Nut, Stover - M16 x 1.5P	2			
13	FS002 - Bell Crank Steering Lever, Right Hand	1			
14	GB073 - DU Flanged Bush 20 id x 23 od x 22 l	2			
15	GG023 - Grease Nipple 45 degree - 6mm	1			
16	FS006 - Bell Crank Steering Lever, Left Hand	1			
17	GB073 - DU Flanged Bush 20 id x 23 od x 22 l	2			
18	GG023 - Grease Nipple 45 degree - 6mm	1			
19	FA089 - Pivot Pin, Bell Crank	2			

Wheel and Brake - Rear

Model: 636HS Green Machine
 From CIN: 13 To CIN: 999
 Drawing: 354819 Revision: 00

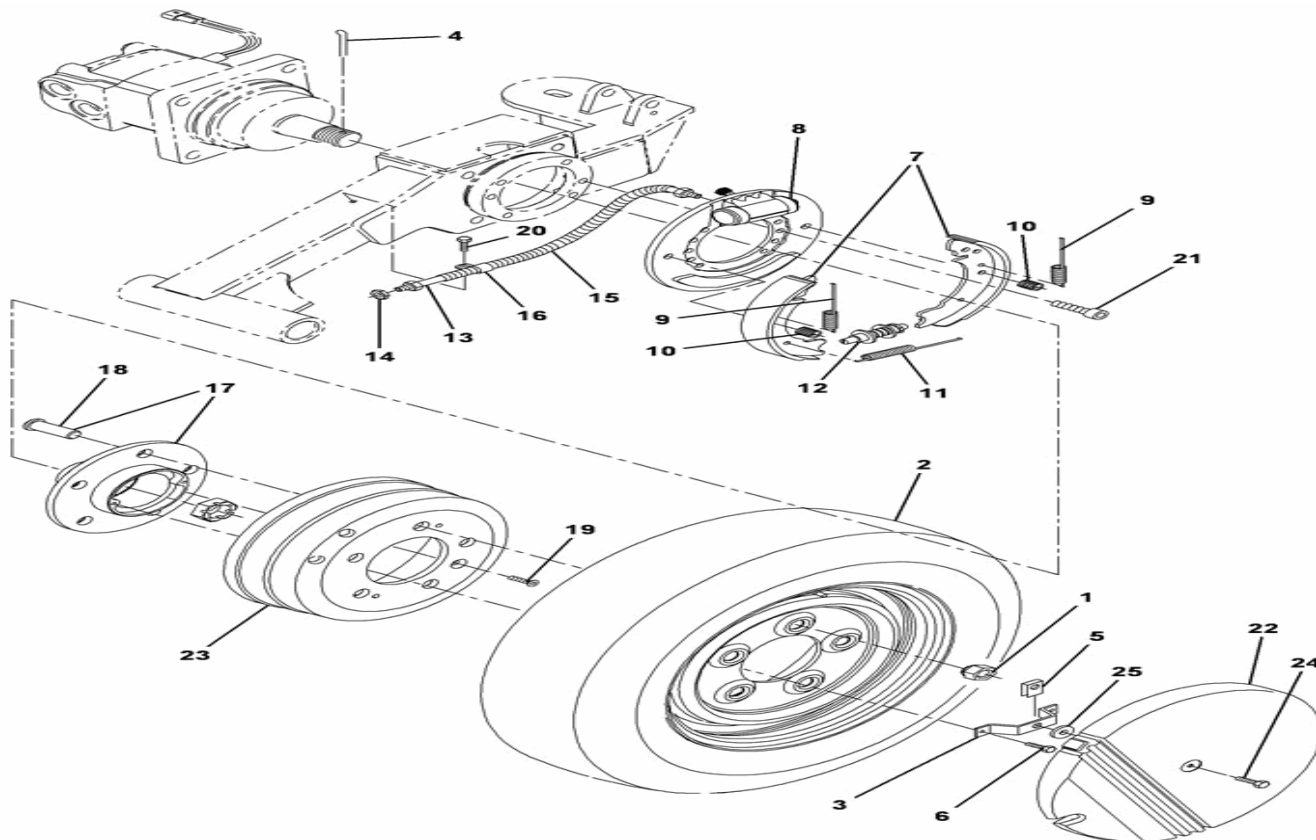

1	GN090 - Wheel Nut, M16 x 1.5p - 636	0	22	TW056 - TW056 - Wheel Trim - 636	2
2	TW055 - Wheel & Tyre Assembly - 636	2	23	CT056 - Rear Brake Drum - 636	2
3	CB946 - Wheel Trim Bracket	2	24	GG256 - Slotted Fastener	2
4	GG249 - Pin ,Split1 1/2" x 1/8"	2	25	GG073 - Dzus Retainer	2
5	GG074 - Clip on receptacle	2			
6	GT234 - M6 x 10 Low Head Socket Cap Screw	4			
7	BB126 - Brake Shoe Replacement Kit	1			
8	BB133 - Wheel Cylinder	2			
9	BB135 - Brake, Upper Tension Spring	4			
10	BB134 - Brake Shoe Steady Spring	4			
11	BB136 - Lower Tension Spring	2			
12	BB127 - Manual Adjuster	2			
13	CT039 - Flexible Hose	2			
14	GN073 - Nut,Hex Lock (Thin) M10 X 1.0P	2			
16	BB079 - P - Clip - ABA Rubber Lined - 13mm	2			
17	CT057 - Rear Wheel Hub c/w Studs - 636	2			
18	GT414 - Wheel Stud - M16 x 1.5 X 47 LG	0			
19	GT302 - Brass Screw, Countersunk M8 x 12	2			
21	GT291 - Screw, Sochet Head Cap - M12 x 20 Zinc	2			

Electrical System-Cab Electronic Management

Model: **636HS Green Machine**
 From CIN: **1** To CIN: **12**
 Drawing: **636090-8** Revision:

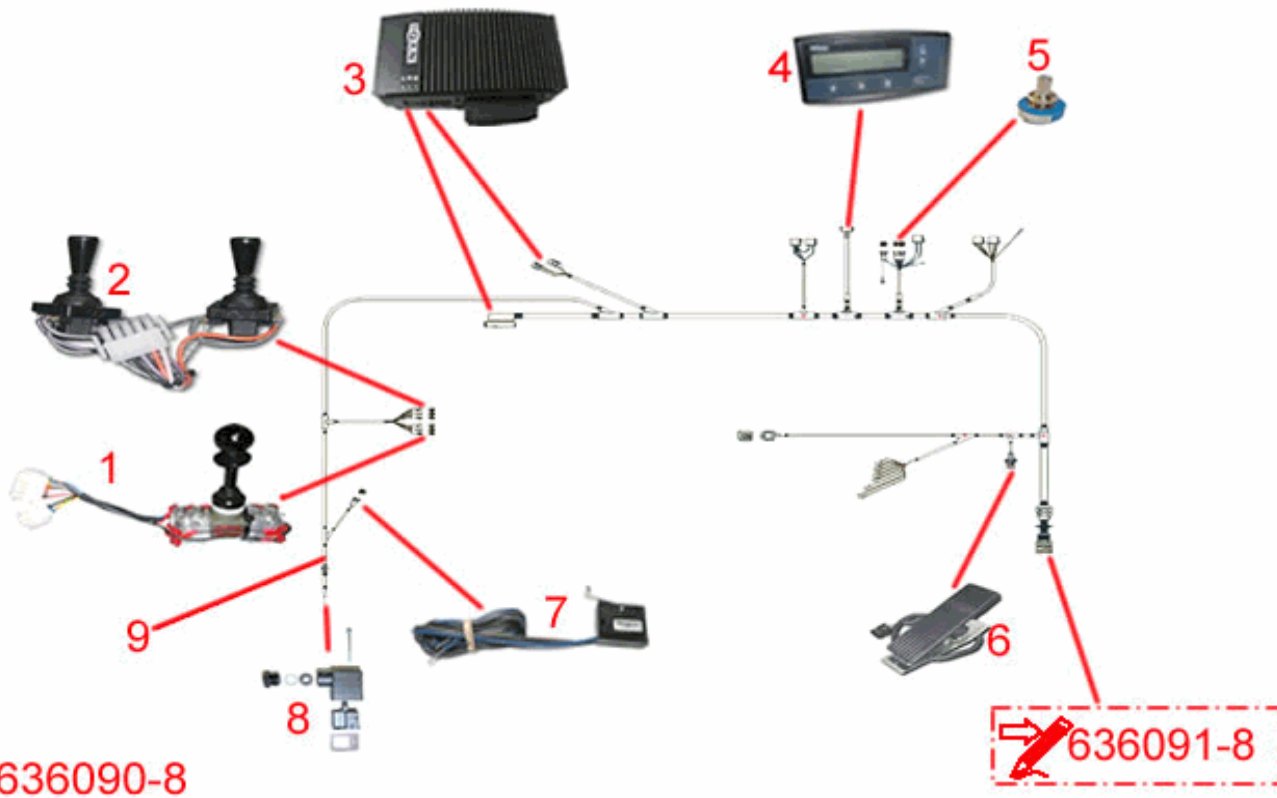

636090-8

1	ES355 - Switch, Joystick - Forward/Neutral/Re	1
2	ES405 - Joystick - Brush Control	1
3	ES329 - IQAN XS Unit,Input-Output	1
4	ES305 - IQAN Master Display - English/French	4
4a	ES312 - IQAN Master Display - German language	4
4b	ES313 - IQAN Master Display - Spanish language	4
4c	ES314 - IQAN Master Display - Portuguese langu	4
4d	ES315 - IQAN Master Display - Italian language	4
4e	ES316 - IQAN Master Display - Swedish language	4
4f	ES317 - IQAN Master Display - Norwegian langua	4
4g	ES318 - IQAN Master Display - Dutch language	4
5	ES351 - Potentiometer-Fan/Brush Speed	2
6	ES284 - Accelerator Pedal	1
7	ES275 - Microswitch,Handbrake	1
8	WP216 - Plug - Solenoid Valve	1
9	EW213 - Wiring Loom-MMU Cab 636	1

4	ES411	IQAN MASTER DISPLKAY - EN/ES KM/H
4	ES412	IQAN MASTER DISPLKAY - DE
4	ES413	IQAN MASTER DISPLKAY - FR
4	ES414	IQAN MASTER DISPLKAY - PT
4	ES415	IQAN MASTER DISPLKAY - IT
4	ES416	IQAN MASTER DISPLKAY - SE
4	ES417	IQAN MASTER DISPLKAY - NO
4	ES418	IQAN MASTER DISPLKAY - NL
4	ES419	IQAN MASTER DISPLKAY - BG
4	ES420	IQAN MASTER DISPLKAY - EN/ES MPH
4	ES449	IQAN MASTER DISPLKAY - EN/CZ
4	ES447	IQAN MASTER DISPLKAY - EN 32 KM/H Transit Speed
4	ES448	IQAN MASTER DISPLKAY - Australian/Canada

Electrical System-Chassis Electronic Management

Model: 636HS Green Machine
 From CIN: 1 To CIN: 12
 Drawing: 636091-8 Revision:

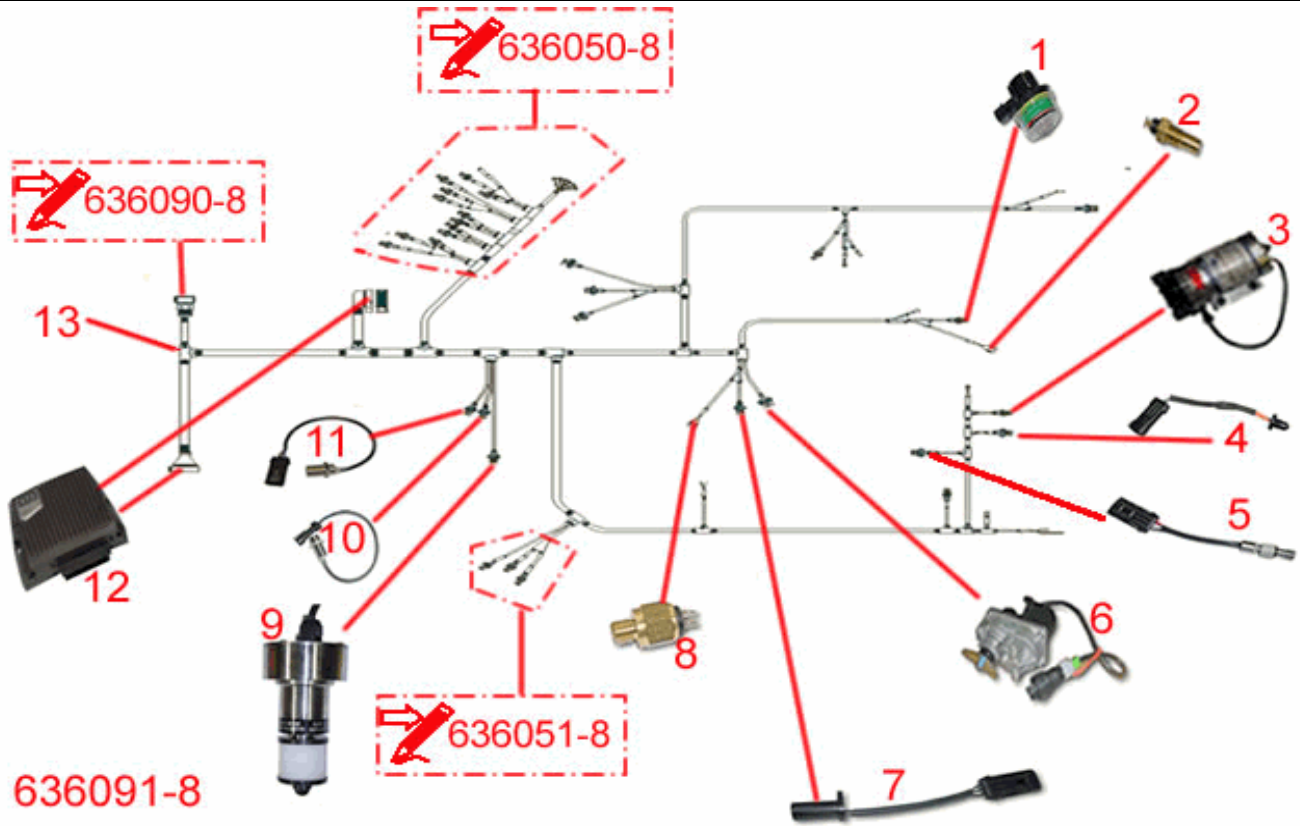

1	ES295 - Air Filter Minder	1
2	EH016 - Temperature Sender	1
3	WP169 - Water Pump c/w Connector	1
4	ES289 - Water Level Sensor c/w plug	1
5	ES285 - Speed Sensor, Wheel Motor with plug	1
6	ES282 - E-Gas Actuator c/w connections	1
7	ES279 - Vacuum Fan/Eng. Speed Sensor c/w plu	1
8	ES253 - Temperature Switch - Hydraulic Oil	1
9	WA269 - Atomising Spray Assembly with plug	1
10	ES280 - Tracking Sensor, IN	1
11	ES281 - Tracking Sensor, OUT	1
12	ES243 - XT2	2
13	EW212 - Wiring Loom-MMU Chassis 636	1

Engine - Cooling System

Model: **636HS Green Machine**
 From CIN: **1** To CIN: **12**
 Drawing: **636049-8** Revision:

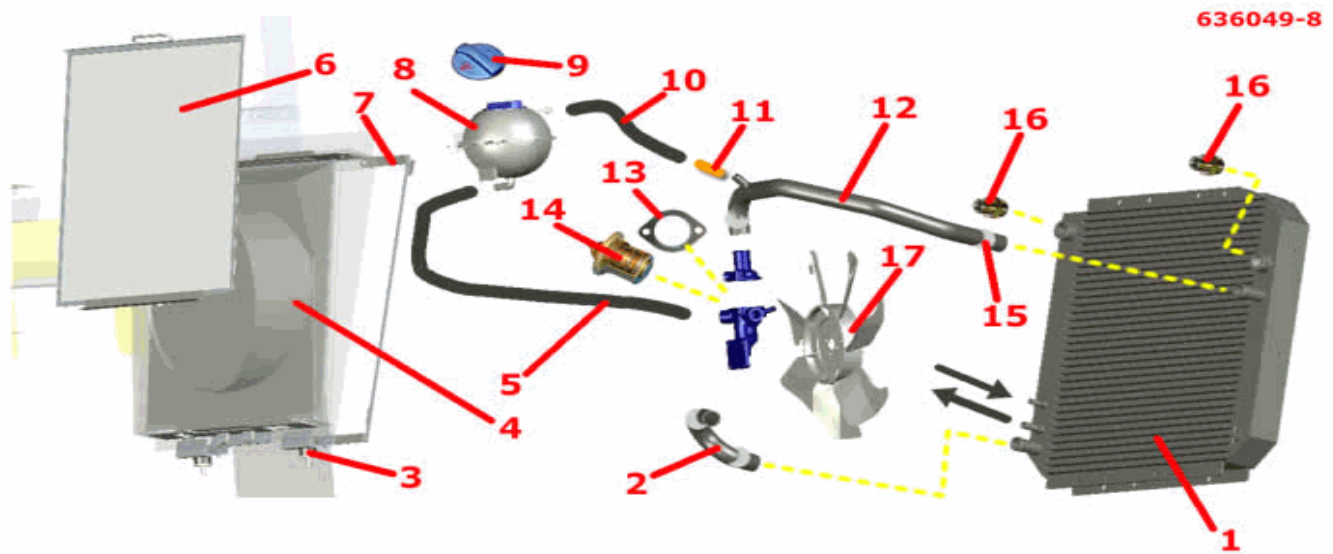

1	PC173 - Radiator - Emmegi - 636	1
2	PP092 - Bottom Hose, Oil Cooler	1
3	PC176 - Bracket - radiator mounting	2
4	PC174 - Radiator shroud - for Emmegi - 636	1
5	PC241 - Hose, Filler - Cooling System	1
6	PC239 - Screen, Radiator	1
7	PC175 - Stay, Radiator	1
8	PC086 - Header Tank	1
9	PC087 - Header Tank Pressure Relief Cap	1
10	PC242 - Hose, Bleed - Cooling System	1
11	PC240 - Pipe, Top Hose - Header Tank	1
12	PC178 - Hose - Top Radiator - Emmegi 636	1
13	PP182 - Gasket, Thermostat	1
14	PP233 - Thermostat Assy	1
16	HF039 - Adaptor, 3/4 to 3/4	2
16a	HF015 - Hydraulic Bonded Seal - 3/4 BSP (26mm)	2
17	PP121 - Fan, Pusher - Multiwing - 8 Blade - 3	1

Engine - Fuel Tank & Filter

Model: **636HS Green Machine**
 From CIN: **1** To CIN: **12**
 Drawing: **636048-8** Revision:

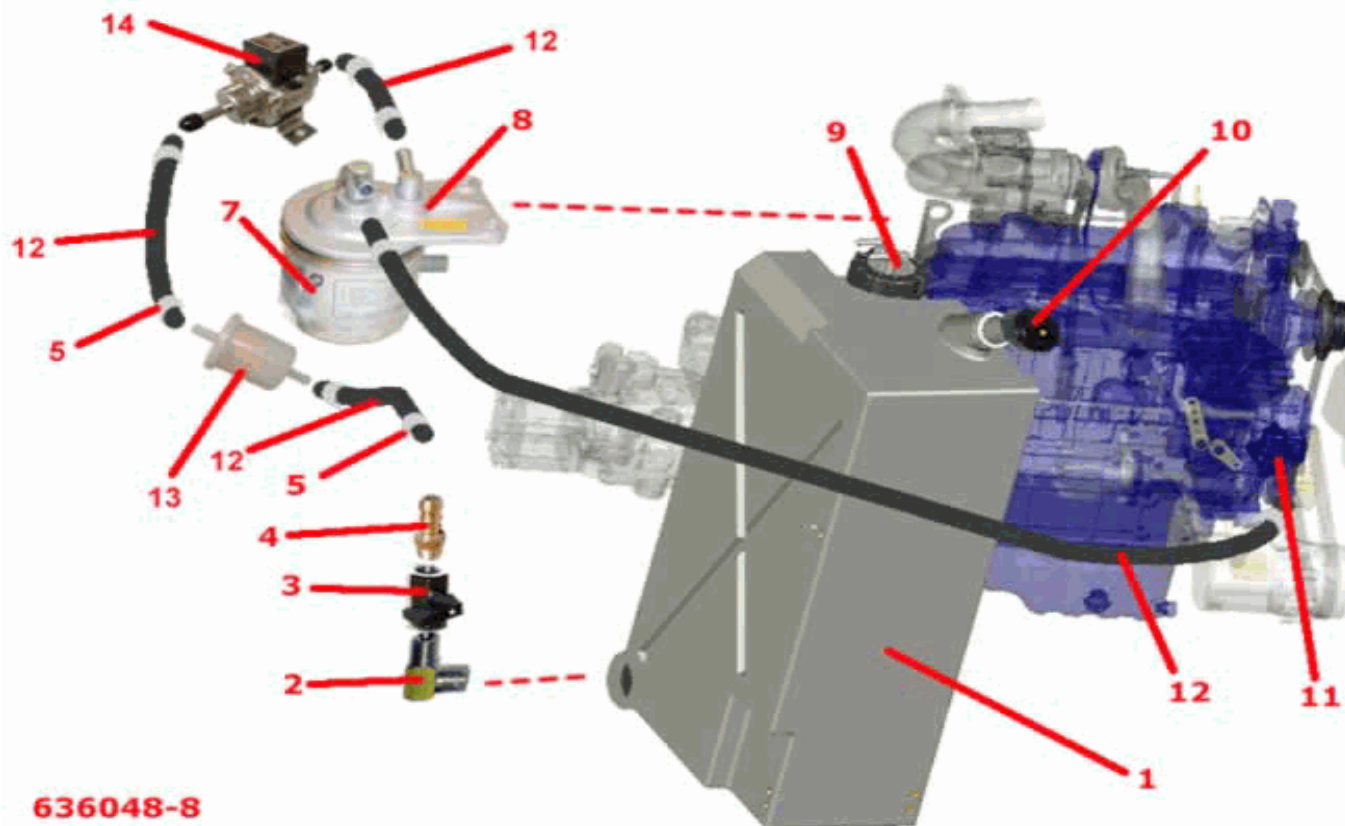

1	PG080 - Diesel Tank	1
2	HF158 - Connector - 1/4	1
3	WP131 - Valve, on/off	1
4	WP036 - Hose Tail - 1/4 BSP -3/8 Hose	1
5	GG045 - Hose Clamp (16mm)	8
7	PP082 - Fuel Filter Element	1
8	PP085 - Fuel Filter Assembly	1
9	PG069 - Fuel Level Sensor (Stainless Tank only)	1
10	PG090 - Diesel Filler Cap, Locking	1
10a	PG068 - Filler Cap - Diesel (stainless tank)	1
12	PG030 - Fuel Pipe	4
13	PP313 - Inline Fuel Filter	1
14	PP298 - Fuel Pump, Electronic	1

Engine - Left Side

Model: 636HS Green Machine
 From CIN: 1 To CIN: 12
 Drawing: 636044-8 Revision:

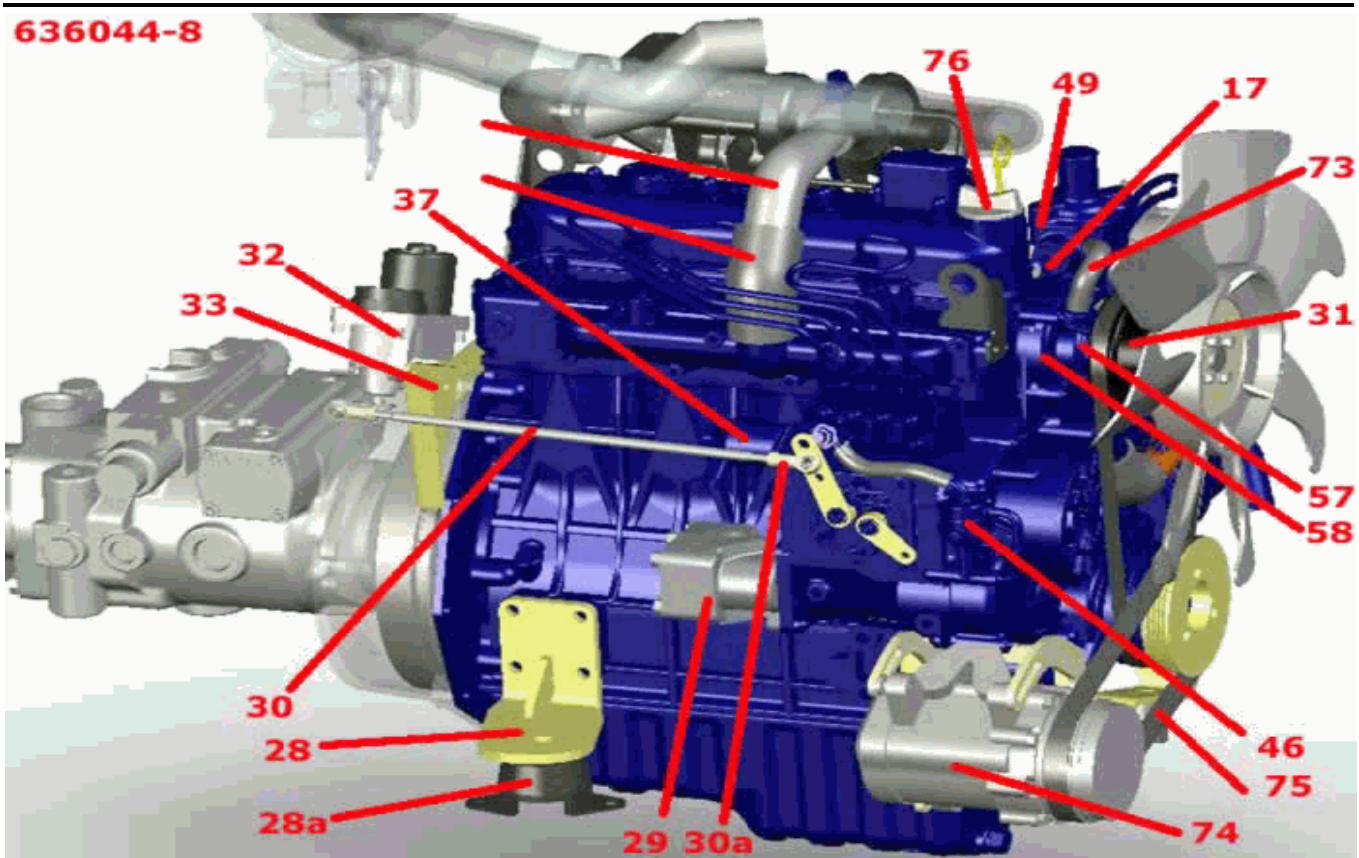

17	EH016 - Temperature Sender	1
28	PP035 - Mounting Bracket LH, Engine	1
28a	GG230 - Rubber Anti-Vibration Mount, Engine	2
29	HP021 - Hydraulic Pump, Steering	1
30	CD268 - Link Rod Assembly, E-gas Actuator - 6	1
30a	BB007 - Rose Bearing	2
31	PP088 - Pulley Fan	1
32	ES282 - E-Gas Actuator c/w connections	1
33	CB793 - Bracket, Support, E Gas Actuator	1
37	PP115 - Fuel Stop Solenoid	1
46	PP179 - Fuel Lift Pump, Mechanical	1
49	PP182 - Gasket, Thermostat	1
57	PP215 - Water Pump Assembly	1
58	PP216 - Gasket, Engine Water Pump	1
73	PP245 - Pipe, Water - Water Pump	1
74	AC058 - Compressor, Air Conditioning	1
74a	AC072 - Compressor Bracket, Air Conditioning	1
75	AC086 - Belt, Compressor - Micro-V - Air Cond	1
76	PD039 - Oil Filler Cap	1

Engine - Rear

Model: 636HS Green Machine
 From CIN: 1 To CIN: 12
 Drawing: 636046-8 Revision:

636046-8

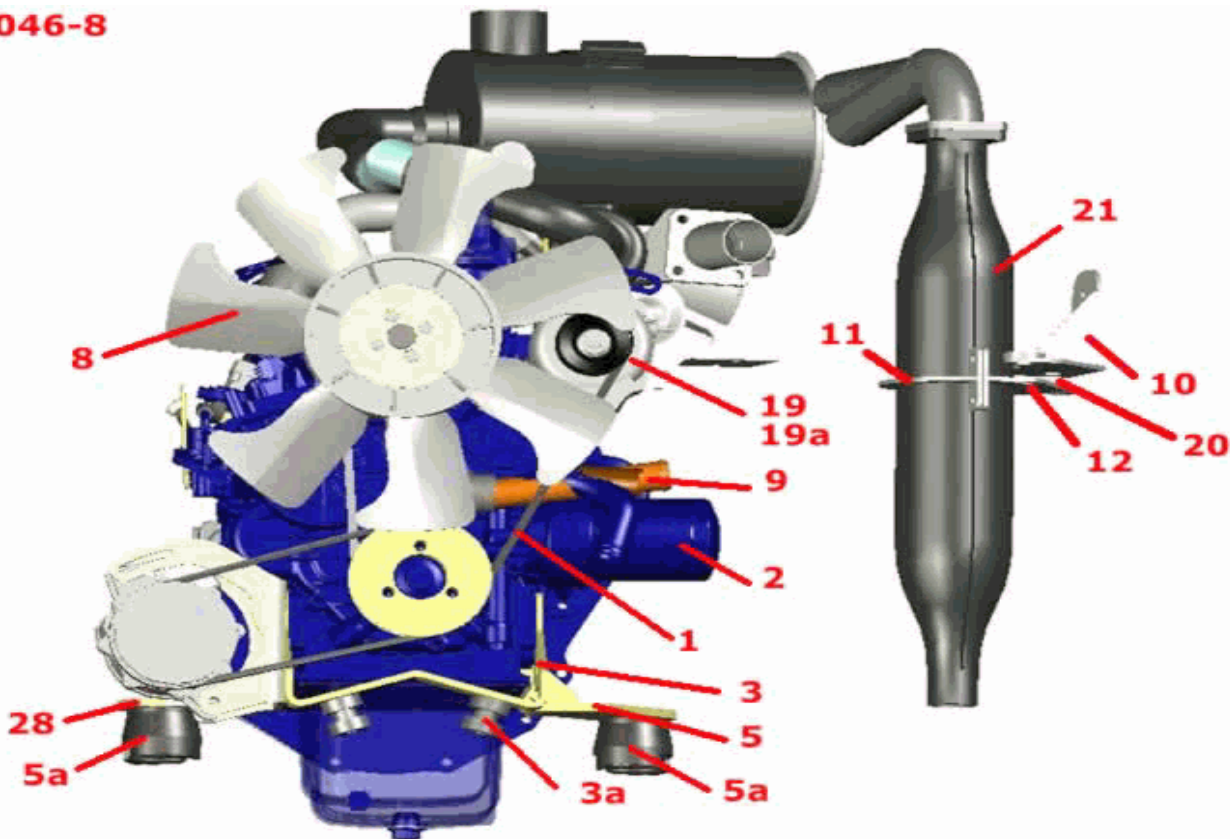

1	PP096 - Fan Belt	1
2	PP083 - Oil Filter Element	1
3	PP193 - Rear Mounting Bracket	1
3a	GG231 - Rubber Anti-Vibration Mount, 2 Piece	2
5	PP034 - Mounting Bracket RH, Engine	1
5a	GG230 - Rubber Anti-Vibration Mount, Engine	2
8	PP347 - Fan, Pusher - Multiwing - 8 Blade - 3	1
8a	PP277 - Spacer, Cooling Fan	1
9	PP093 - Water Pipe	1
10	PP206 - Bracket	1
11	PP207 - Bracket	1
12	PP208 - Bracket	1
19	PP133 - 60 Amp Alternator	1
19a	PP159 - 90 Amp Alternator	1
19b	PP163 - Connector Kit for PP159	1
20	GG231 - Rubber Anti-Vibration Mount, 2 Piece	1
21	PP095 - Muffler Exhaust	1
28	PP035 - Mounting Bracket LH, Engine	1
29	PP353 - Flexi-Pipe, Exhaust	1

Engine - Right Side

Model: **636HS Green Machine**

From CIN: **1** To CIN: **2**

Drawing: **636045-8** Revision:

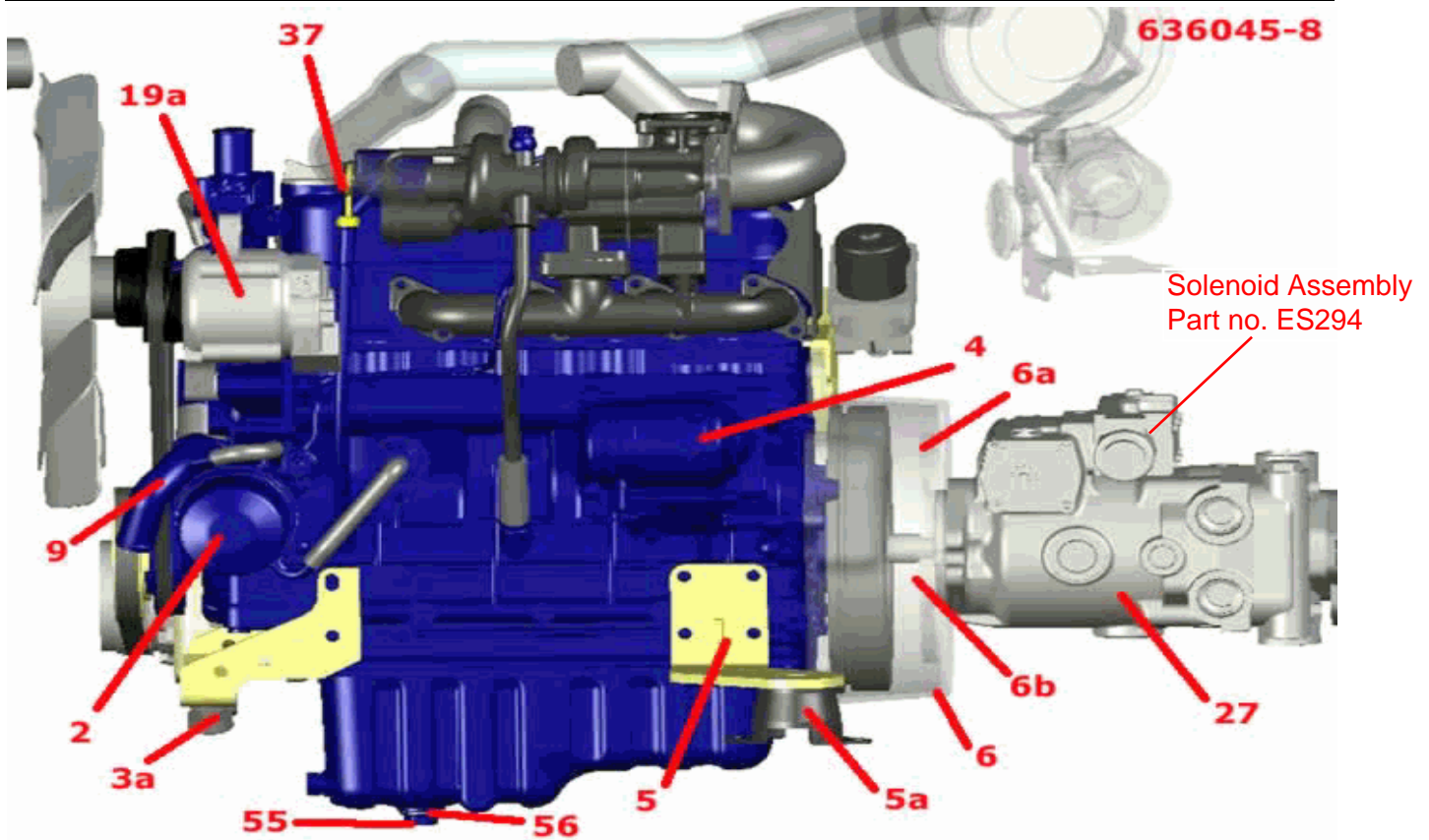

2	PP083 - Oil Filter Element	1	19b	PP163 - Connector Kit for PP159	1
2	PP083 - Oil Filter Element	1	19b	PP163 - Connector Kit for PP159	1
3a	GG231 - Rubber Anti-Vibration Mount, 2 Piece	2	27	HP032 - Transmission Pump c/w Connector-11 to	1
3a	GG231 - Rubber Anti-Vibration Mount, 2 Piece	2	27	HP030 - Transmission Pump c/w Connector-9 Too	1
4	PP097 - Starter Assembly	1	27a	GM410 - Solenoid Protector Kit	1
4	PP097 - Starter Assembly	1	27a	HP032 - Transmission Pump c/w Connector-11 to	1
5	PP034 - Mounting Bracket RH, Engine	1	27b	GM410 - Solenoid Protector Kit	1
5	PP034 - Mounting Bracket RH, Engine	1	37	PP350 - Dipstick Kit	1
5a	GG230 - Rubber Anti-Vibration Mount, Engine	2	37	PP350 - Dipstick Kit	1
6	PP276 - Engine/Pump Housing - M14 Pump Fixing	1	55	PP213 - Plug, Drain - Sump	1
6	PP004 - Engine Housing	1	55	PP213 - Plug, Drain - Sump	1
6a	PP274 - Drive Coupling, Bobbin Type	1	56	PP214 - Gasket, Drain Plug	1
6a	PP274 - Drive Coupling, Bobbin Type	1	56	PP214 - Gasket, Drain Plug	1
9	PP093 - Water Pipe	1			
9	PP093 - Water Pipe	1			
19	PP133 - 60 Amp Alternator	1			
19	PP133 - 60 Amp Alternator	1			
19a	PP159 - 90 Amp Alternator	1			
19a	PP159 - 90 Amp Alternator	1			

Engine - Top View

Model: 636HS Green Machine
 From CIN: 1 To CIN: 12
 Drawing: 636047-8 Revision:

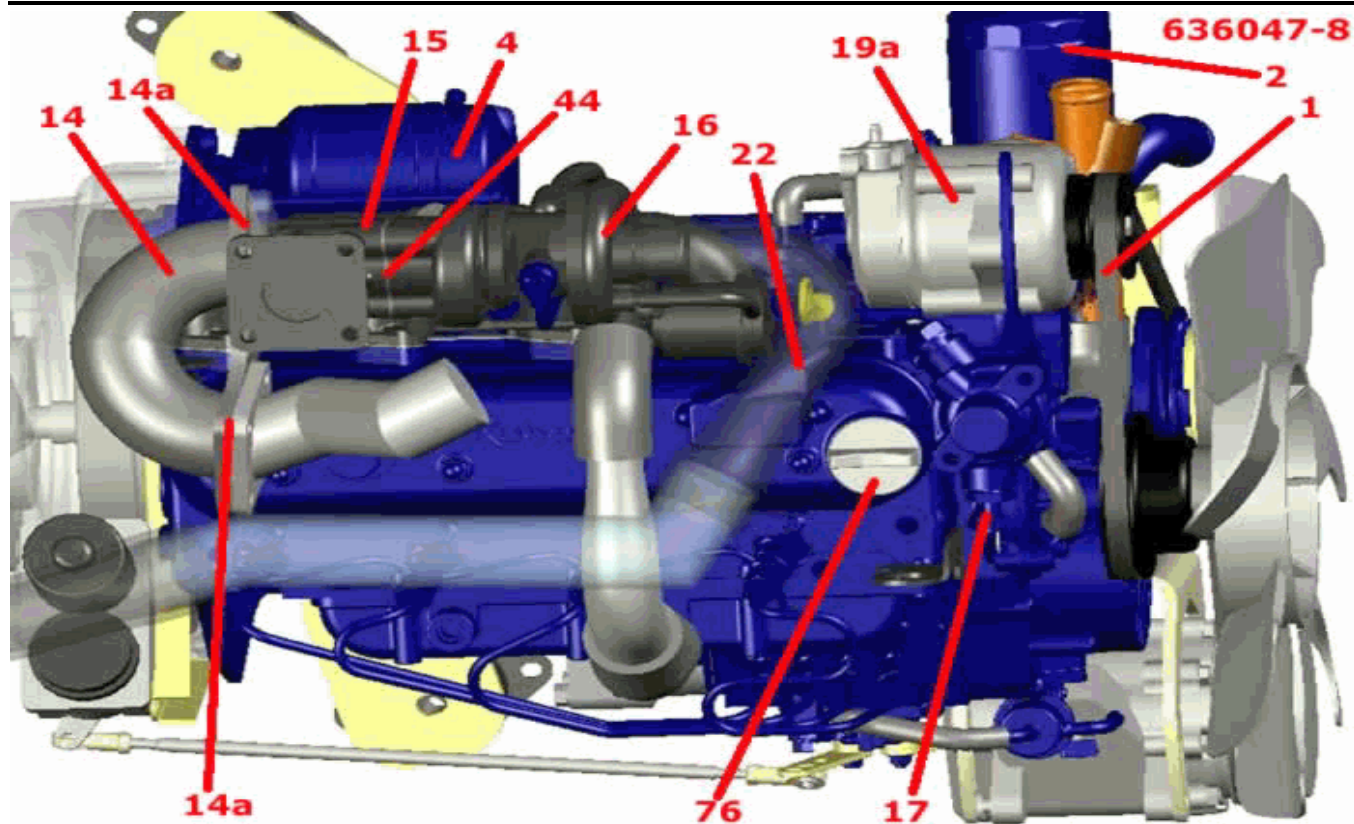

1	PP096 - Fan Belt	1
1a	PP196 - Fan Belt - Air Con Machine	1
2	PP083 - Oil Filter Element	1
4	PP097 - Starter Assembly	1
14	PP326 - Exhaust Manifold Weldment - 636	1
14a	PP089 - Muffler Gasket	2
15	PP087 - Flange, Turbo	1
16	PP098 - Turbocharger Assembly	1
17	EH016 - Temperature Sender	1
19	PP133 - 60 Amp Alternator	1
19a	PP159 - 90 Amp Alternator	1
19b	PP163 - Connector Kit for PP159	1
22	PP104 - Hose, Pipe to Turbo	1
44	PP169 - Gasket, Turbo to Muffler Flange	1
76	PD039 - Oil Filler Cap	1

Engine Air Filter

Model: **636HS Green Machine**
 From CIN: **13** To CIN: **999**
 Drawing: **354842** Revision: **00**

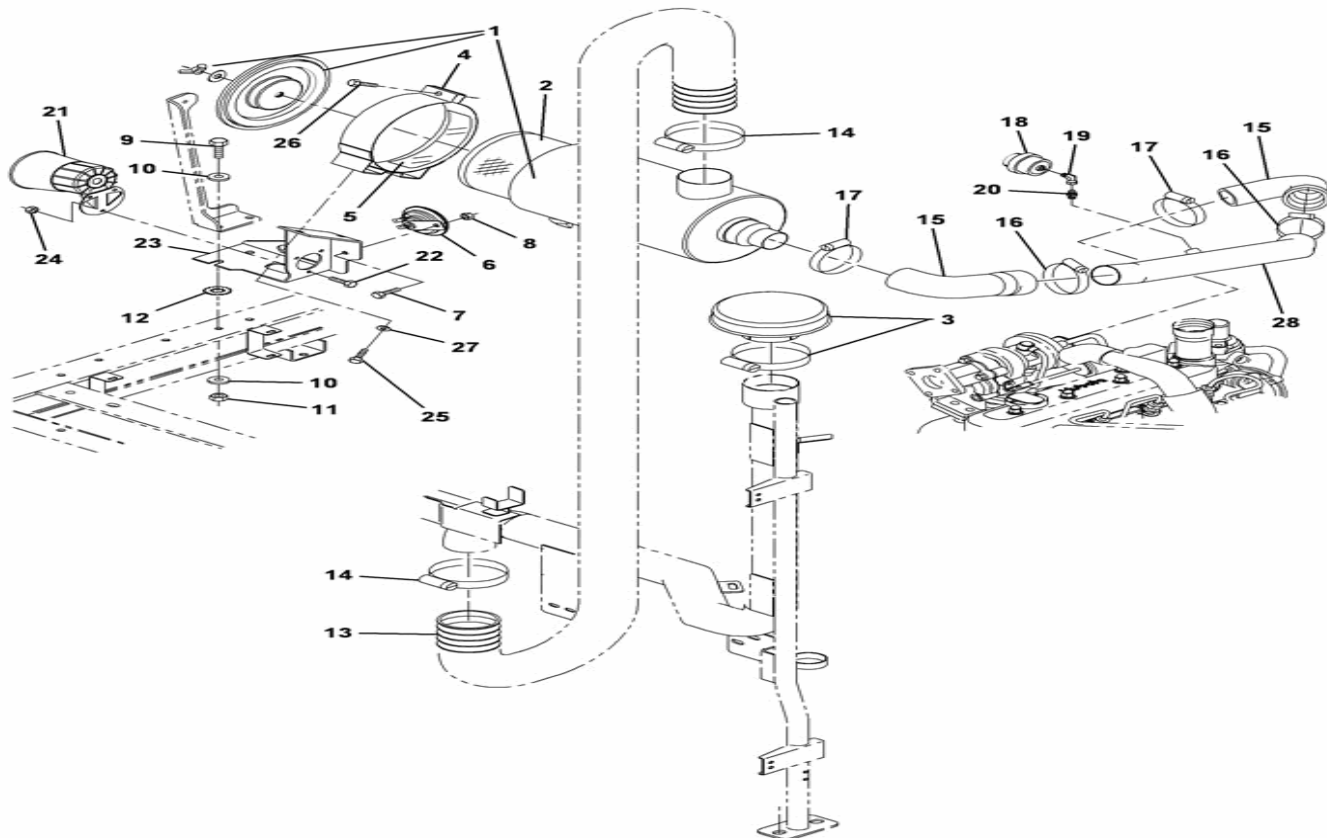

1	PP101 - Air Cleaner	1	25	GT028 - M8 x 20 Setscrew	2
2	PP084 - Air Filter Element	1	26	GT042 - M8 x 30 Hex Screw	1
3	PP284 - Air Precleaner	1	27	GW060 - M8 Washer Form A st.st.	2
4	PP102 - Air Cleaner Band	1	28	PP440 - Tube Weldment, Turbo - Air Cleaner	1
5	GM013 - Rubber band - 8 in. diameter	1			
6	ES451 - Horn	1			
7	GT327 - M6 x 16 Stainless Steel Button Head	1			
9	GT395 - Bolt,Hex Head SET M8 x 110 MM	2			
12	GW032 - M8 Flat Washer	1			
13	PC113 - Air Cleaner Intake Hose	1			
15	PP103 - Hose. Air Cleaner to Pipe	2			
17	GG066 - Hose Clamp (50mm)	2			
18	ES295 - Air Filter Minder	1			
19	PP436 - Connector - 1/8"BSPM x 2/8"BSPF 90 DE	1			
20	ES099 - Nipple for filter minder	1			
21	ES162 - English Language Voice Box (standard	1			
22	GT378 - Screw,Button Head Socket -M5 x 10 ST	3			
23	CD065 - Bracket,Weldment,Air Filter	1			
24	GN042 - M5 Locknut - nylon	3			

Engine Battery and Alternator

Model: **636HS Green Machine**
 From CIN: **13** To CIN: **999**
 Drawing: **354871** Revision: **00**

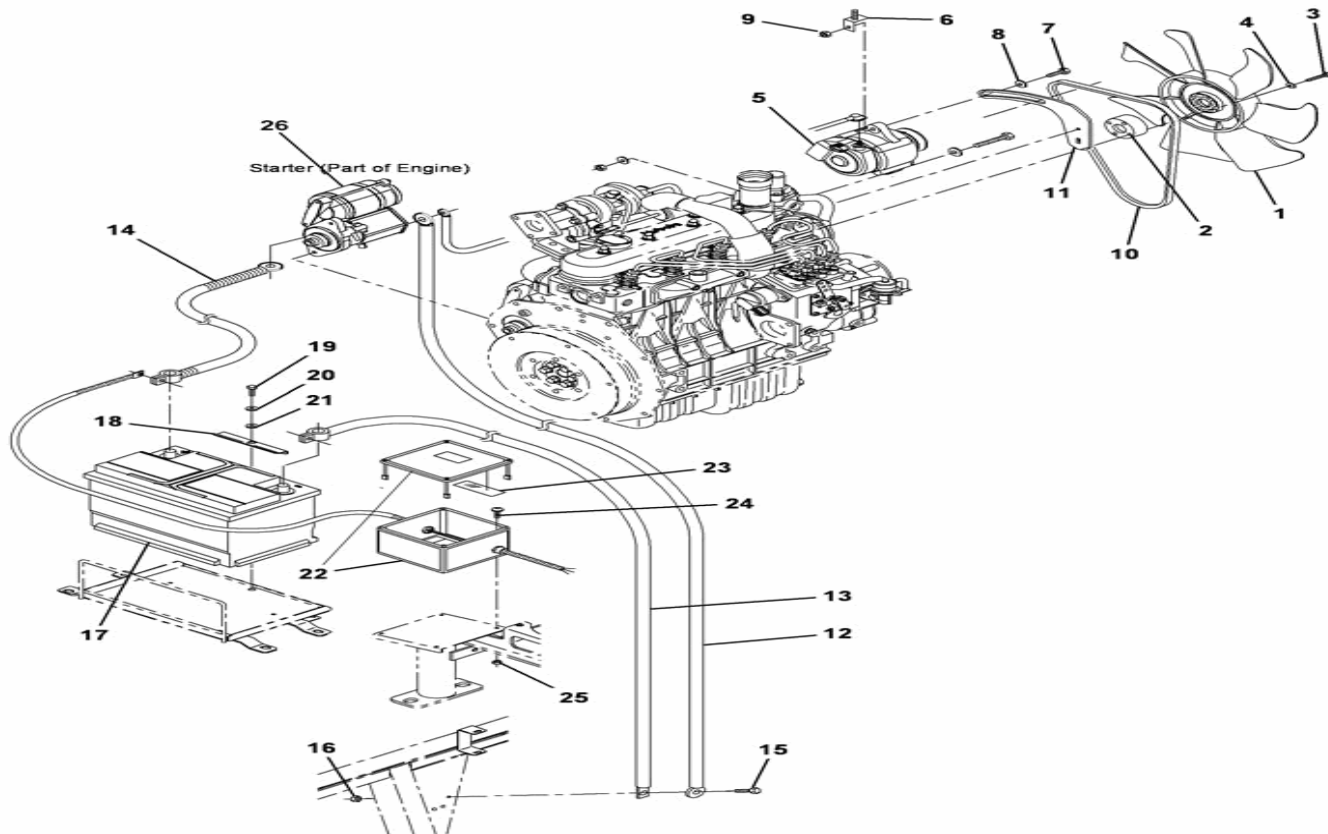

1	PP347 - Fan, Pusher - Multiwing - 8 Blade - 3	1	21	GW060 - M8 Washer Form A st.st.	1
2	PP277 - Spacer, Cooling Fan	1	22	EW218 - Fusebox, 4 x 40A	1
3	GT071 - Screw, Hex Head - M6 x 50	4	23	GM455 - Label, Primary Fuse Box	1
4	GW003 - Spring Washer	4	24	GT278 - Screw, Button Head - M4 x 20	4
5	PP133 - 60 Amp Alternator	1	25	GN024 - M4 Locknut - Nylon	4
6	CD386 - P - Clip Bracket - Coolant Heater Hos	1			
7	GT089 - M8 x 35 Hex Setscrew	1			
8	GW041 - M8 Washer Form A	1			
9	GN043 - M8 locknut - nylon - stainless steel	1			
10	PP096 - Fan Belt	1			
11	PP134 - Stay -(60amp Alternator)	1			
12	ET063 - Earth Cable	1			
14	ET138 - Cable, Positive Battery	1			
14	ET139 - Cable, Negative Battery	1			
15	GT287 - M8 x 20 Hex Head Screw (Stainless Ste	1			
16	GN043 - M8 locknut - nylon - stainless steel	1			
18	PP073 - Battery Clamp Plate	1			
19	GT303 - Screw, Hex Head M8 x 25	1			
20	GW015 - M8 Split Lockwasher	1			

Engine Bay -Ancillary Components

Model: 636HS Green Machine
 From CIN: 1 To CIN: 12
 Drawing: 636089-8 Revision:

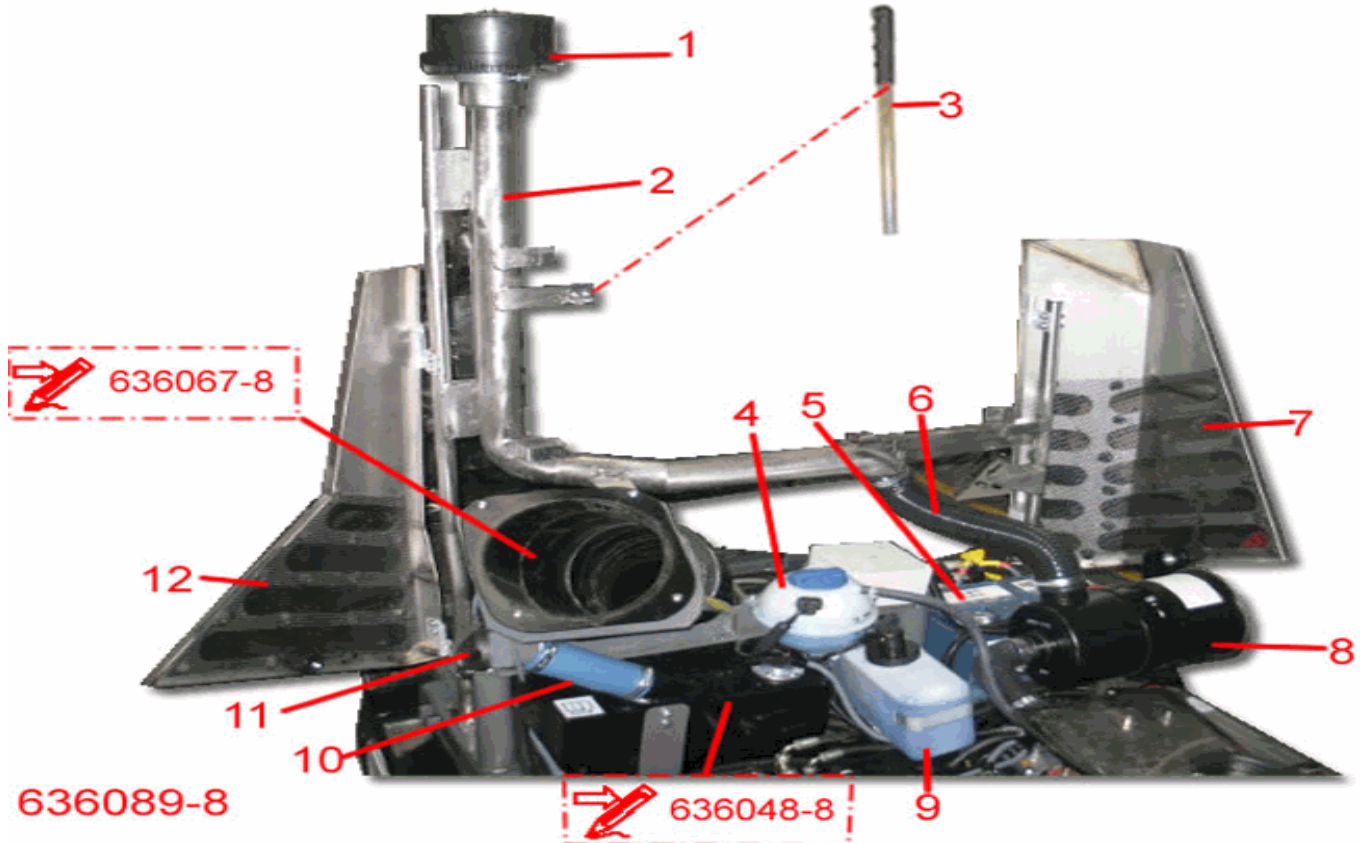

1	PP284 - Air Precleaner	1
2	PP325 - PP325 - Air Intake Tube and Support F	1
3	BB142 - Hand Pump Lever Assembly	1
4	PC086 - Header Tank	1
4a	PC087 - Header Tank Pressure Relief Cap	1
5	EM011 - Battery	1
6	PC113 - Air Cleaner Intake Hose	1
7	CD087 - CD087 - Access Door,Right Hand,Hinged	1
8	PP101 - Air Cleaner	1
8a	PP084 - Air Filter Element	1
8b	PP102 - Air Cleaner Band	1
8c	PP103 - Hose. Air Cleaner to Pipe	2
8d	PP040 - Air Cleaner Pipe	1
9	WA105 - Water Bottle c/w Pump (windscreen was	1
10	PG098 - PG098 - Filler Hose,Diesel Tank	1
11	PG090 - PG090 - Diesel Filler Cap,Locking	1
12	CD088 - CD088 - Access Door,Left Hand,Hinged	1

Engine Fuel Supply

Model: 636HS Green Machine
 From CIN: 13 To CIN: 999
 Drawing: 354830 Revision: 00

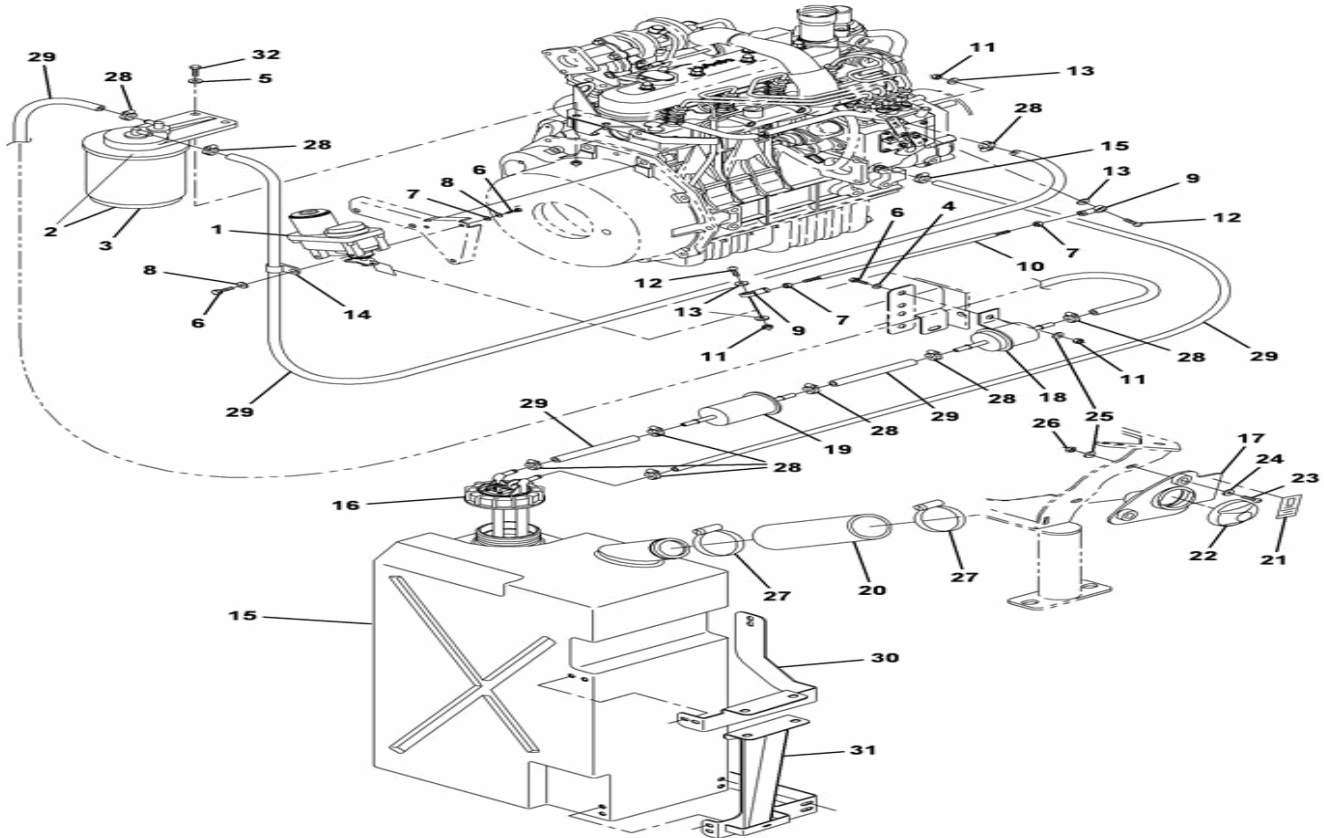

1	ES282 - E-Gas Actuator c/w connections	1
2	PP085 - Fuel Filter Assembly	1
3	PP082 - Fuel Filter Element	1
9	BB007 - Rose Bearing	2
10	CD070 - Control Rod, ECS	2
12	GT329 - Screw,Button Head Hex Socket - M6 x 2	2
15	PG099 - Diesel Tank - Rotomould	1
16	PG102 - Fuel Sender, Off - Take (Rotomold Tank only)	1
17	PG092 - Remote Filler Weldment	1
18	PP298 - Fuel Pump, Electronic	1
19	PP313 - Inline Fuel Filter	1
21	GM534 - Label, Low Sulphur Fuel	1
22	PG090 - PG090 - Diesel Filler Cap,Locking	1
22a	PG112 - Key, Locking Fuel Cap	1
23	GT108 - Screw, Button Head Hex Socket - M8 x	2
30	CD076 - Bracket,Fuel Tank -Top	1
31	CD078 - Bracket,Fuel Tank - Bottom	1

Engine Mount

Model: **636HS Green Machine**
 From CIN: **13** To CIN: **999**
 Drawing: **354828** Revision: **00**

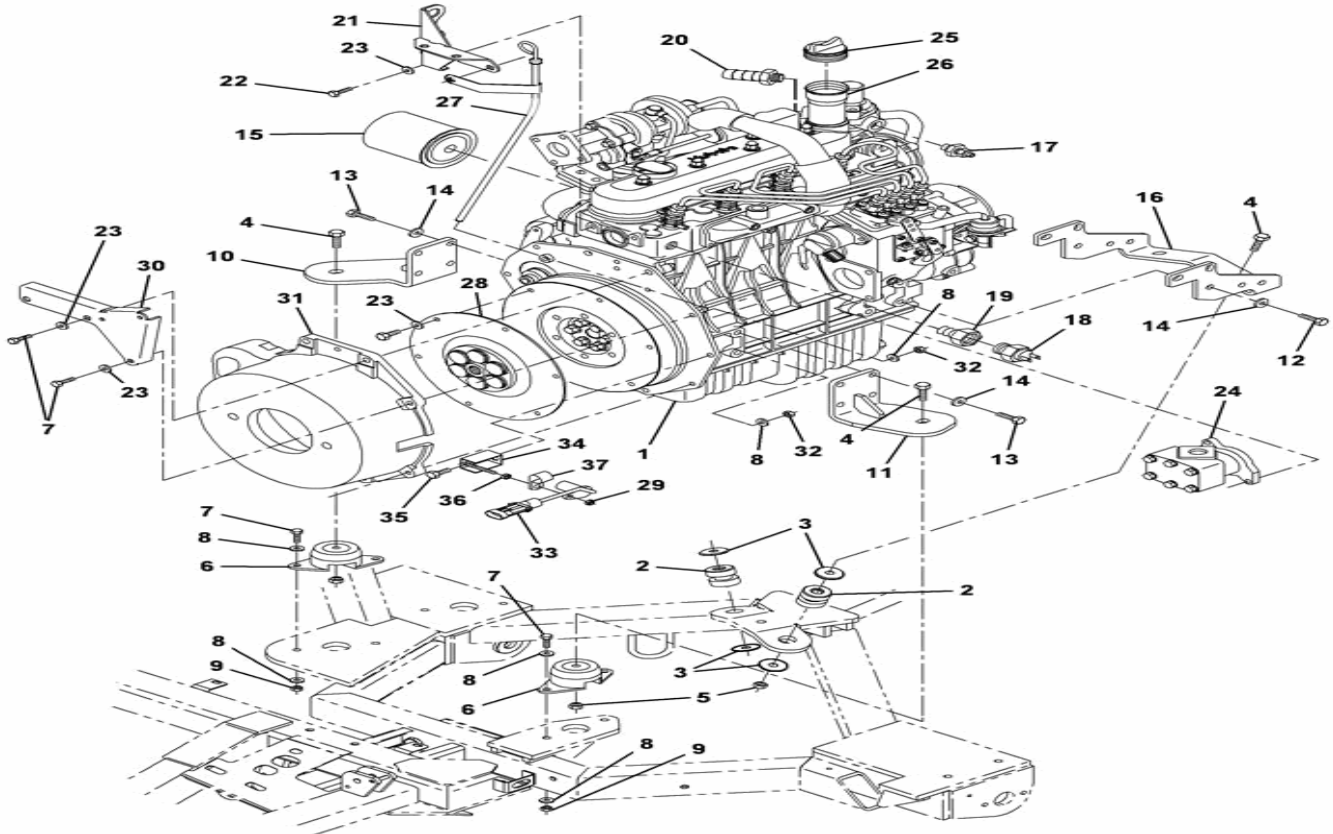

1	PP438 - Engine, V1505T 4 Cylinder Turbo	1	31	PP276 - Engine/Pump Housing - M14 Pump Fixing	1
2	GG231 - Rubber Anti-Vibration Mount, 2 Piece	2	33	ES279 - Vacuum Fan/Eng. Speed Sensor c/w plu	1
3	GW027 - Dished Washer	4	34	CB810 - Bracket, Support, Engine Speed Sensor	1
4	GT298 - Bolt	4			
6	GG230 - Rubber Anti-Vibration Mount, Engine	2			
10	PP034 - Mounting Bracket RH, Engine	1			
11	PP035 - Mounting Bracket LH, Engine	1			
15	PP083 - Oil Filter Element	1			
16	PP367 - Bracket, Rear Twin Mounting Engine	1			
17	EH016 - Temperature Sender	1			
18	ES257 - Engine Temperature Switch	1			
20	WP154 - Hose Tail, 3/8 BSP to 1/2" internal	1			
21	CB799 - Bracket, Support, Fuel Filter	1			
24	HP021 - Hydraulic Pump, Steering	1			
25	PD039 - Oil Filler Cap	1			
26	PP091 - Oil Filler Flange, Extended	1			
27	PP112 - Dipstick/Oil Gauge	1			
28	PP274 - Drive Coupling, Bobbin Type	1			
30	CB793 - Bracket, Support, E Gas Actuator	1			

Engine Muffler

Model: **636HS Green Machine**
 From CIN: **13** To CIN: **999**
 Drawing: **354829** Revision: **00**

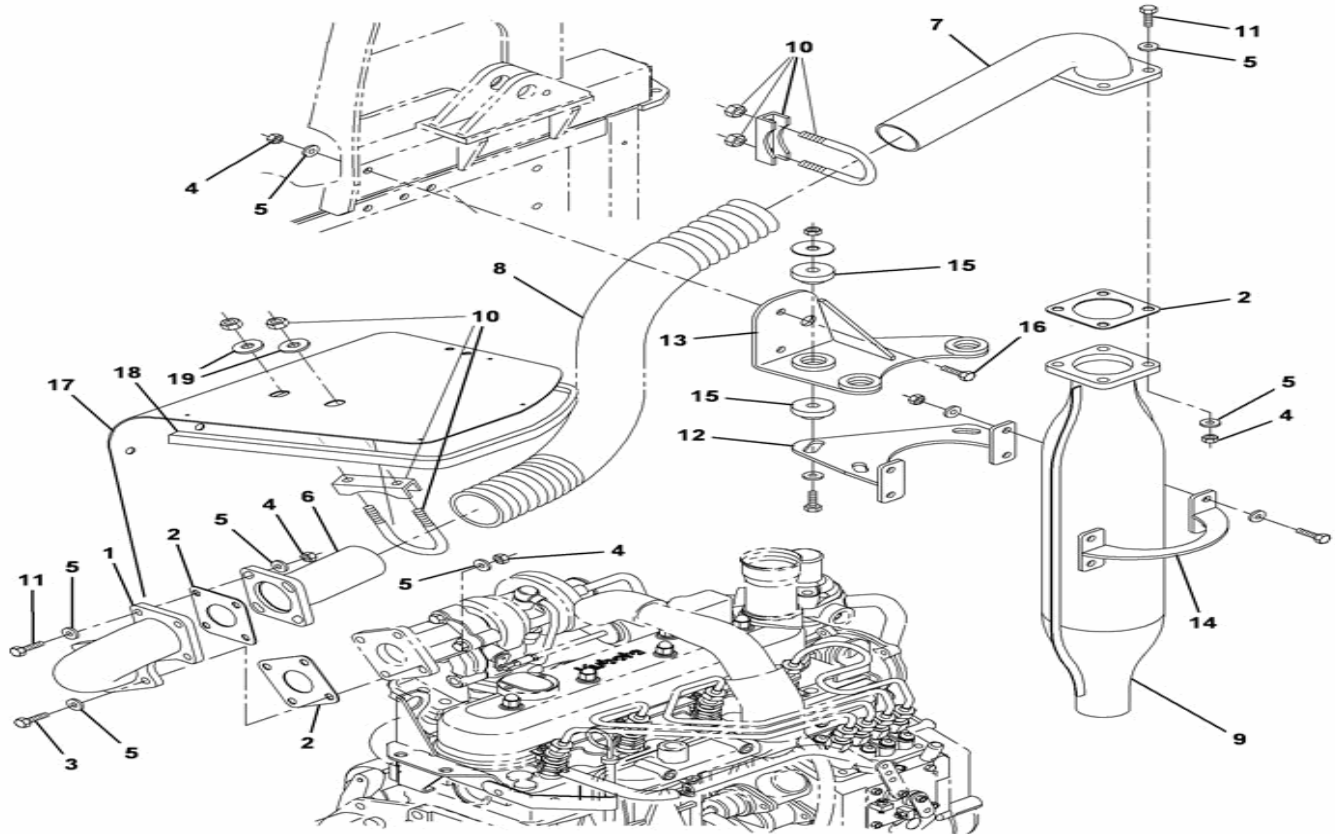

1	PP326 - Exhaust Manifold Weldment - 636	1
2	PP089 - Muffler Gasket	3
6	PP217 - Exhaust Pipe	1
7	PP218 - Pipe Exhaust	1
8	PP353 - Flexi-Pipe, Exhaust	1
9	PP095 - Muffler Exhaust	1
11	GT042 - M8 x 30 Hex Screw	8
12	PP208 - Bracket	1
13	PP206 - Bracket	1
14	PP207 - Bracket	1
15	GG231 - Rubber Anti-Vibration Mount, 2 Piece	3
16	GT377 - Bolt Hex Head M8 x 75 ST.ST A4	2
17	PC208 - Shield, Engine to Radiator	1
18	KM338 - Seal - Engine to Radiator Shield	1
19	GW021 - Washer, M8 x 25	2

Engine Radiator Hoses

Model: **636HS Green Machine**
 From CIN: **13** To CIN: **999**
 Drawing: **354836** Revision: **00**

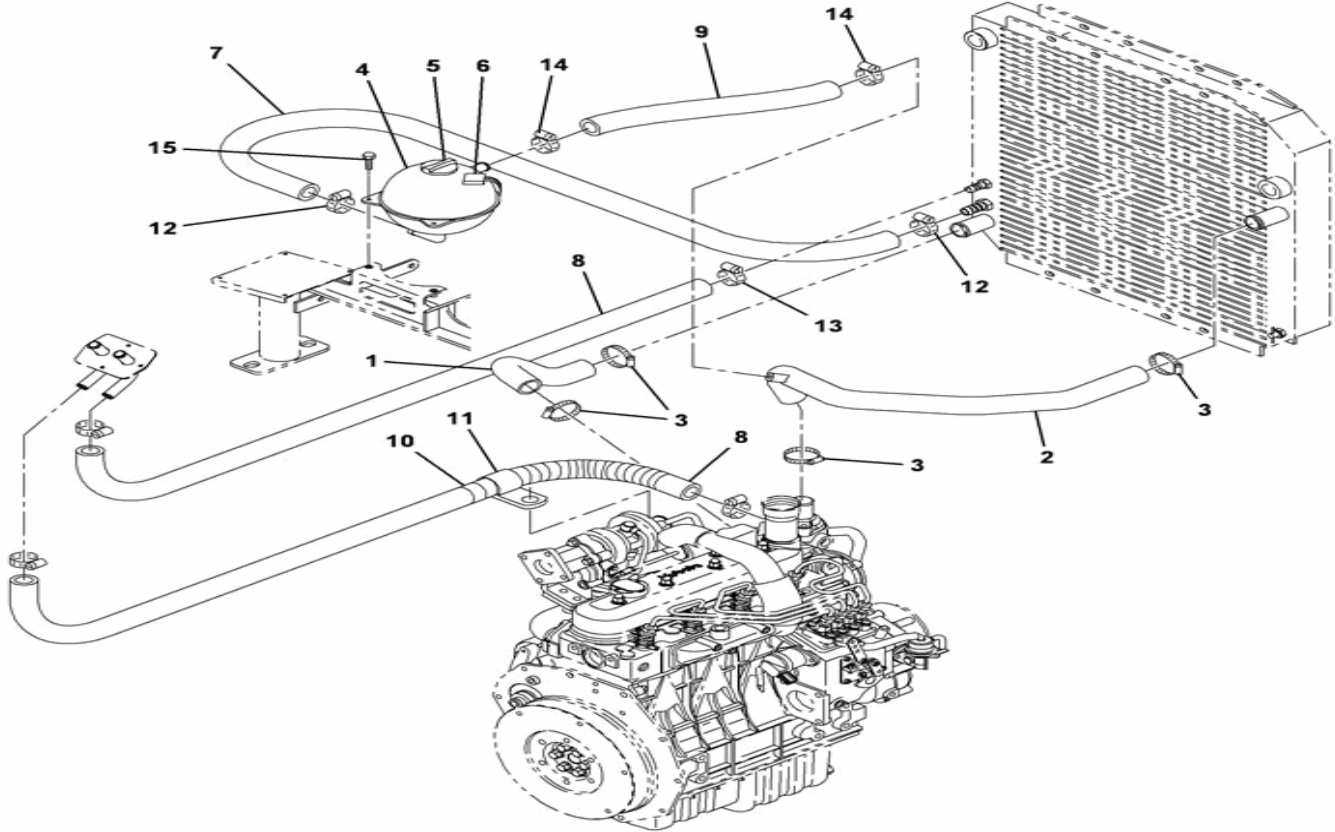

1	PP092 - Bottom Hose, Oil Cooler	1
2	PC178 - Hose - Top Radiator - Emmegi 636	1
4	PC086 - Header Tank	1
5	PC087 - Header Tank Pressure Relief Cap	1
6	ES362 - Sensor, Coolant Expansion Tank	1
7	WA288 - Hose, radiator To Expansion Bottle -	1
8	PC247 - PC247 - Heater Hose-Radiator to Heate	2
9	WA285 - Hose, Breather Top Radiator - 8mm	1
12	GG090 - Hose Clamp (17mm to 25mm)	1
13	GG077 - Hose Clamp (14mm to 22mm)	2
15	GT327 - M6 x 16 Stainless Steel Button Head	2

Engine Radiator Mount

Model: **636HS Green Machine**
 From CIN: **13** To CIN: **999**
 Drawing: **354835** Revision: **00**

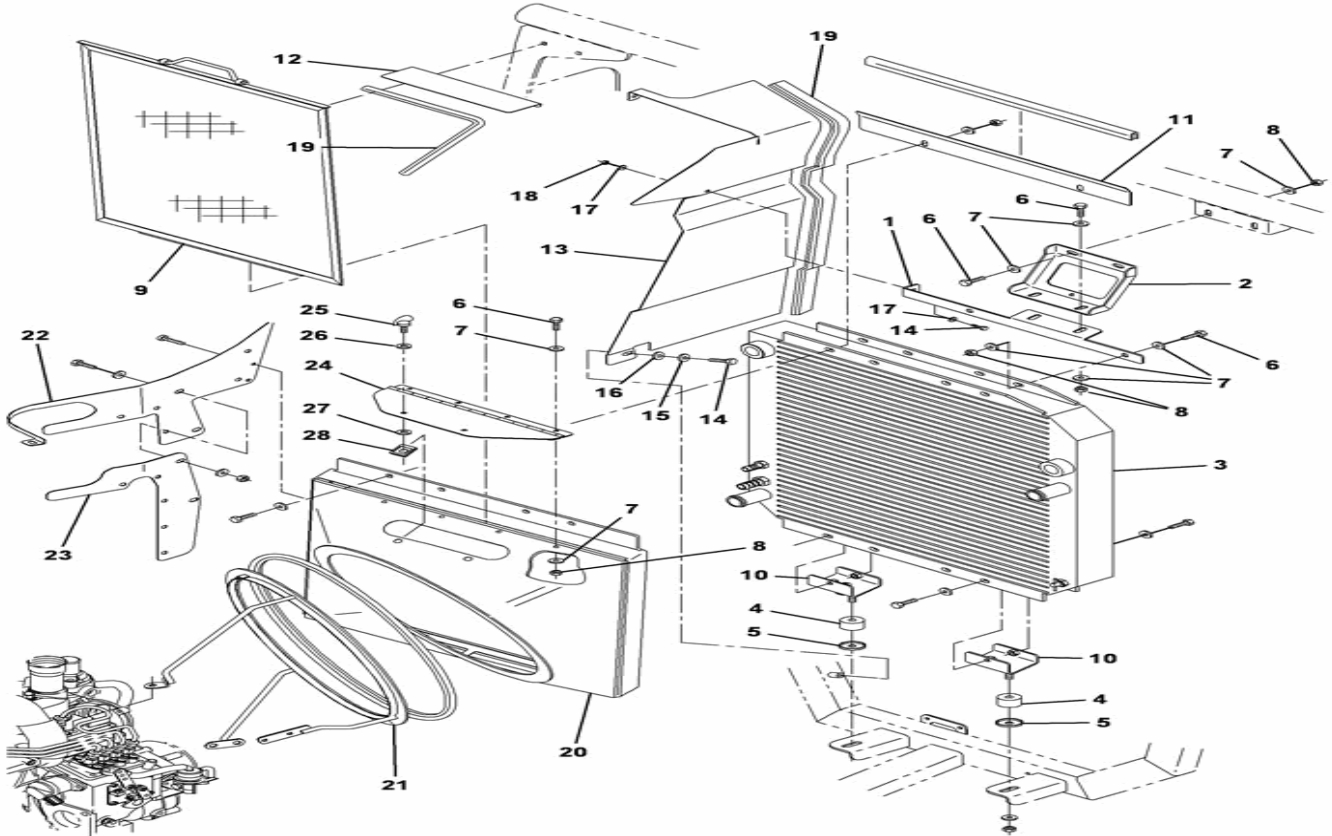

1	PC243 - Stay,Radiator	1	28	GG042 - Slip on receptacle	2
2	PC245 - Bracket, Mounting	1			
3	PC173 - Radiator - Emmegi - 636	1			
4	GG054 - Bush rubber bushing	2			
5	GW027 - Dished Washer	2			
9	PC296 - Mesh Screen - Radiator	1			
10	PC176 - Bracket - radiator mounting	2			
11	PC219 - Shield,Top Radiator	1			
12	PC222 - Shield Chassis,Hopper	1			
13	PC216 - Sheild, Bottom Radiator	1			
20	PC279 - Cowl Body, Vacform	1			
20	PC279 - Cowl Body, Vacform	1			
21	PC282 - Fan Guard Assembly	1			
22	PC214 - Shield, Top Radiator To Engine	1			
23	PC228 - Shield, radiator To Hopper	1			
24	PC295 - Access Cover	1			
25	GG048 - Ring Head Stud - 14 mm	2			
26	GG055 - Plastic Washer (6mm)	2			
27	GG041 - Retainer Washer - steel	2			

Rear - Decals & Ancillaries

Model: **636HS Green Machine**
 From CIN: **1** To CIN: **12**
 Drawing: **636098-8** Revision:

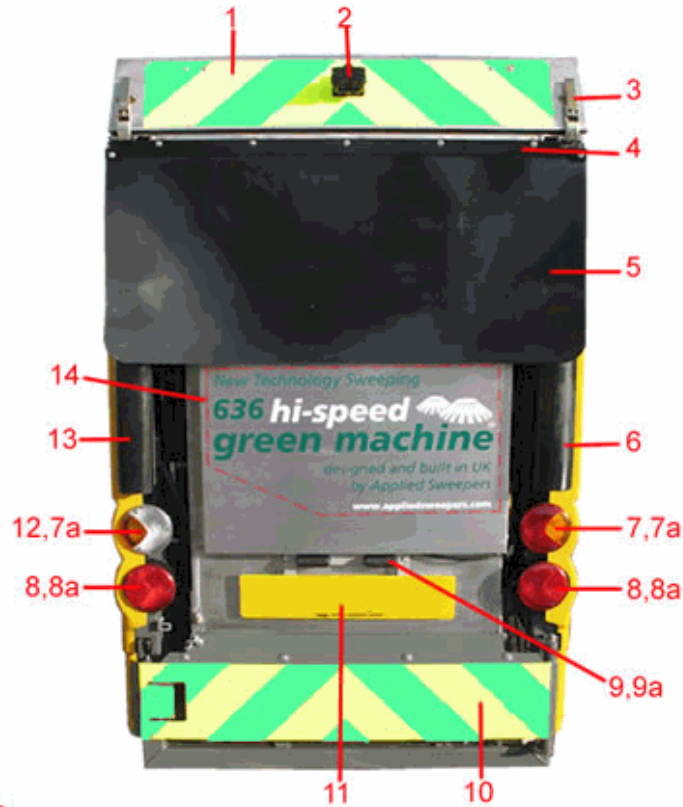

636098-8

1	GM395 - Decal, Chevron - Hopper	1
2	EC021 - Rear View Camera, Low Light	1
3	GG156 - Adjustable Latch	2
4	VH163 - Rubber Aprons Retaining Plates	1
5	VH164 - Rubber Apron	1
6	GM463 - GM463 - Bumper,Rear Right Hand	1
7	ES255 - Indicator / Fog Lamp	1
7a	ES032 - Bulb 12V 21W	4
8	ES254 - Rear / Brake Lamp	2
8a	ES276 - Bulb for ES254	2
9	ES062 - Light - number plate	2
9a	ES053 - Bulb - festoon type - 12V 5W	2
10	GM394 - Decal, Chevron - Bumper	1
11	WA136 - Number Plate Fixing Bracket	1
12	ES256 - Indicator / Reverse Lamp	1
13	GM294 - GM294 - Bumper,Rear Left Hand	1
14	GM440 - GM440 - Decal,Rear Panel	1

Recommended Stockholding - Smaller Fleets 636HS

Model: **636HS Green Machine**
 From CIN: **1** To CIN: **12**
 Drawing: **636100-8** Revision:



636100-8

This list shows the faster moving parts that we recommend owners of smaller fleets (1 or 2 machines) should keep in stock.

1	GG287 - Fan Inspection Door Key	1	19	WP165 - Spray Nozzle Holder Assy (Brushes)	2
2	ES276 - Bulb for ES254	2	20	WP221 - Spray Jet - Red	1
3	CD154 - Seal,Drain Flap	1			
4	HC058 - Filter Element	1			
5	HC154 - Element - Filter , Suction & Return	1			
6	NA138 - Horseshoe Wear Pad	1			
7	NB058 - Brush - Poly - 500/600 Series	8			
8	NB059 - Brush - P.E.T. - 500/600 Series	2			
9	NB061 - Brush - Poly/wire mix - 500/600 Serie	4			
10	NN112 - Side Skid Shoe	4			
11	PP082 - Fuel Filter Element	6			
12	PP083 - Oil Filter Element	6			
13	PP084 - Air Filter Element	2			
14	VH373 - Cyclone Spinner Bearing Kit	1			
15	WA206 - Bobbin - for spray head atomiser	1			
16	WP020 - Filter with anti-drip valve	2			
17	WP060 - Spray Jet - Green	1			
18	WP160 - Jet Spray	2			

Side - Decals & Ancillaries

Model: **636HS Green Machine**
 From CIN: **1** To CIN: **12**
 Drawing: **636097-8** Revision:

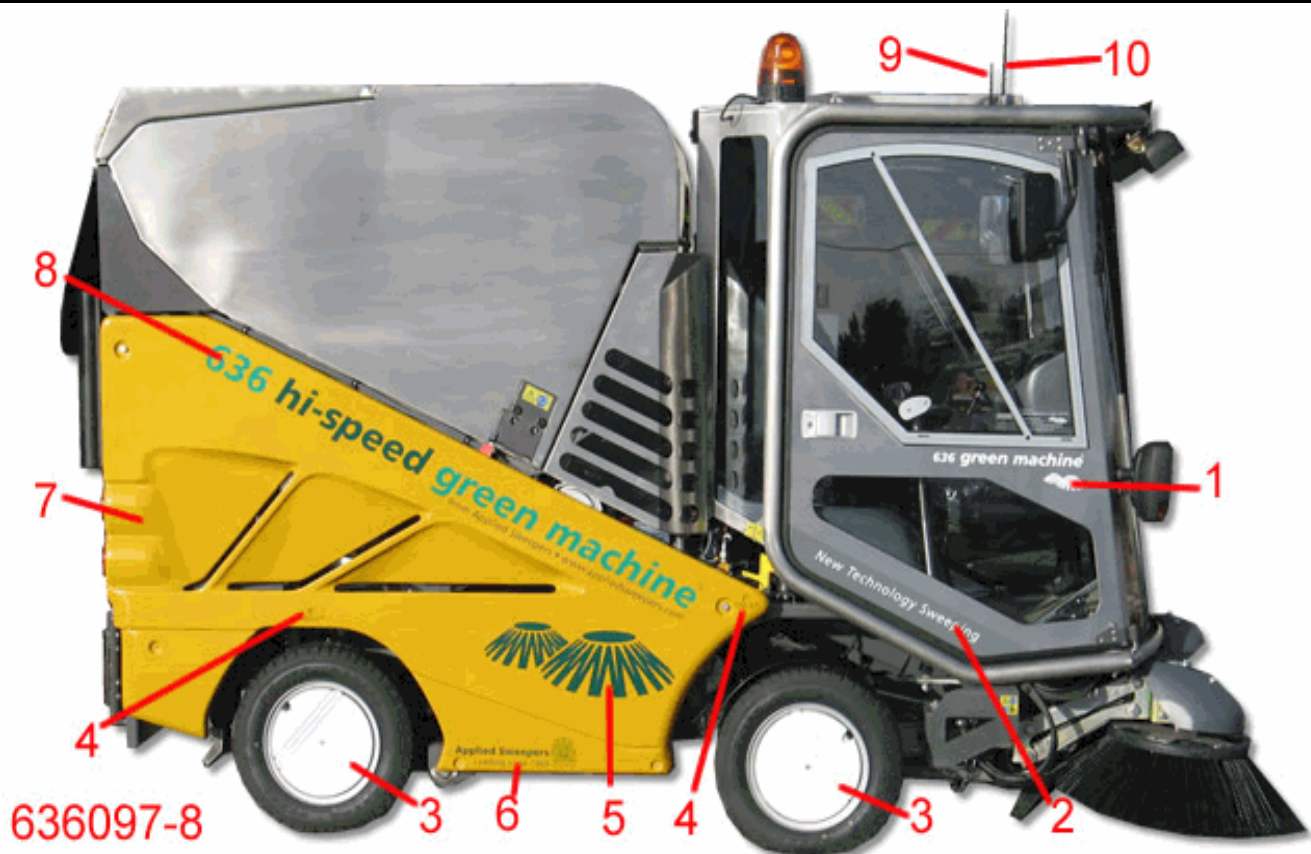

1	GM441 - GM441 - Decal,Middle Right Hand Door	1
1a	GM442 - GM442 - Decal,Middle Left Hand Door	1
2	GM297 - Decal, RH Door (Bottom)	1
2a	GM298 - Decal, LH Door (Bottom)	1
3	TW056 - TW056 - Wheel Trim - 636	4
3a	CB946 - Wheel Trim Bracket	4
4	GM451 - Tyre Pressure Label - 636	4
5	GM438 - GM438 - Decal,Side Panel,Brush Motif	2
6	GM306 - Decal, RH Side Panel (bottom)	1
6a	GM301 - Decal, LH Side Panel (bottom)	1
7	CP233 - CP233 - Side Panel,Right Hand with De	1
7a	CP232 - CP232 - Side Panel,Left Hand with Dec	1
8	GM437 - GM437 - Decal,Side Panel,UK	2
9	ES269 - Antenna Base	1
9a	ES268 - Whip Antenna	1
10	EC014 - Aerial, Flexible Rubber	1

Side Panel - Left Hand

Model: **636HS Green Machine**
 From CIN: **13** To CIN: **999**
 Drawing: **354869** Revision: **00**

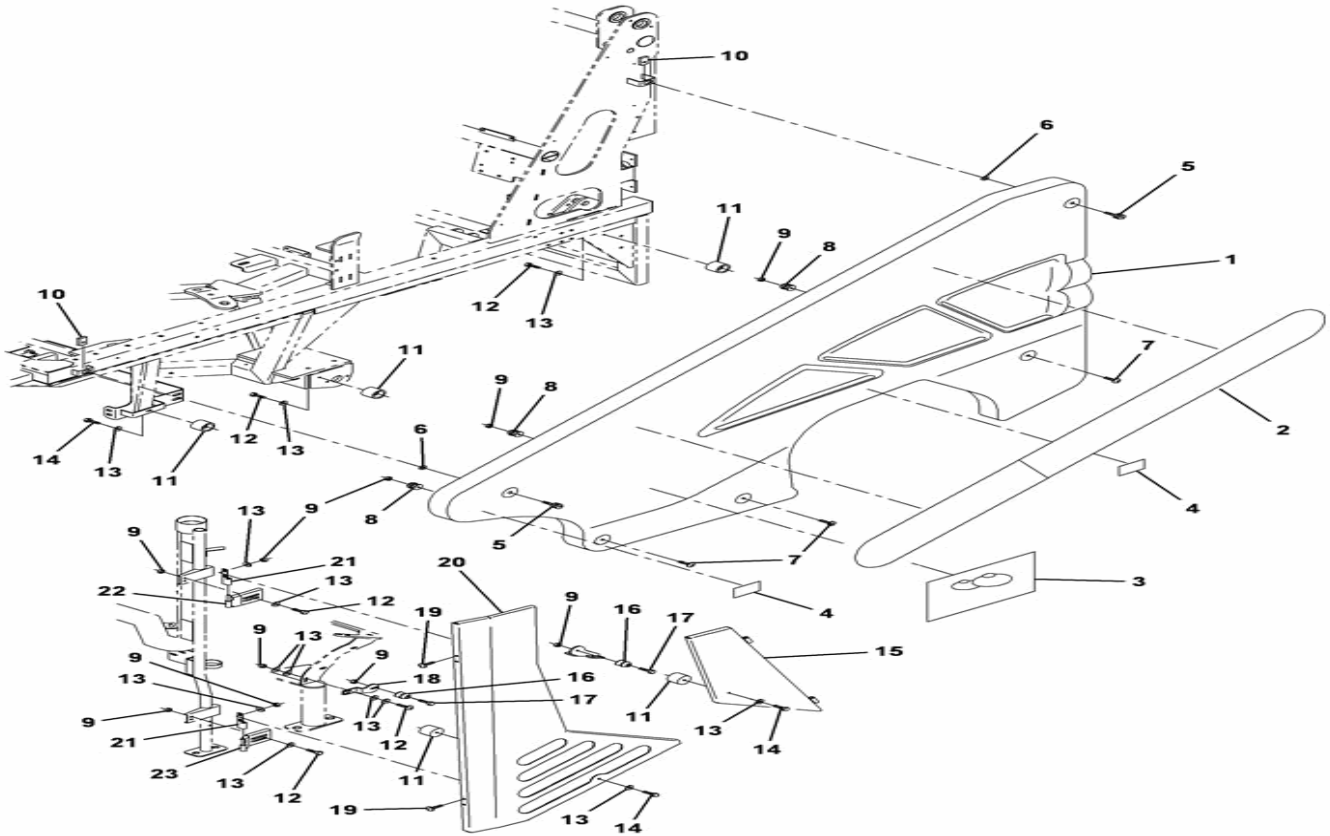

1	CP232 - CP232 - Side Panel,Left Hand with Dec	1
2	GM505 - Decal, Side Panel Green/White	1
3	GM517 - Decal, Side Panel Green/White	1
4	GM451 - Tyre Pressure Label - 636	2
5	GG146 - Knurled panel screw	2
6	GG148 - Retaining washer - plastic	2
7	GT338 - Screw,Button Head Hex Socket - M6 x 3	3
8	GG033 - Door Stop - male	3
10	GG147 - Slip on receptacle	2
11	GG044 - Door Stop - female	5
15	CD305 - Fixed Panel, Left Hand	1
16	GG033 - Door Stop - male	2
18	CD121 - Doorstop Mounting Bracket	1
19	GT320 - Screw, Button Head Hex Socket - M6 x	4
21	CD458 - Left Hand Side Door Hinge Assembly	2
21	CD458 - Left Hand Side Door Hinge Assembly	2
22	CD463 - Left Hand Upper Hinge Assembly	1
23	CD465 - Left Hand Lower Hinge Assembly	1

Side Panel - Right Hand

Model: **636HS Green Machine**
 From CIN: **13** To CIN: **999**
 Drawing: **354870** Revision: **00**

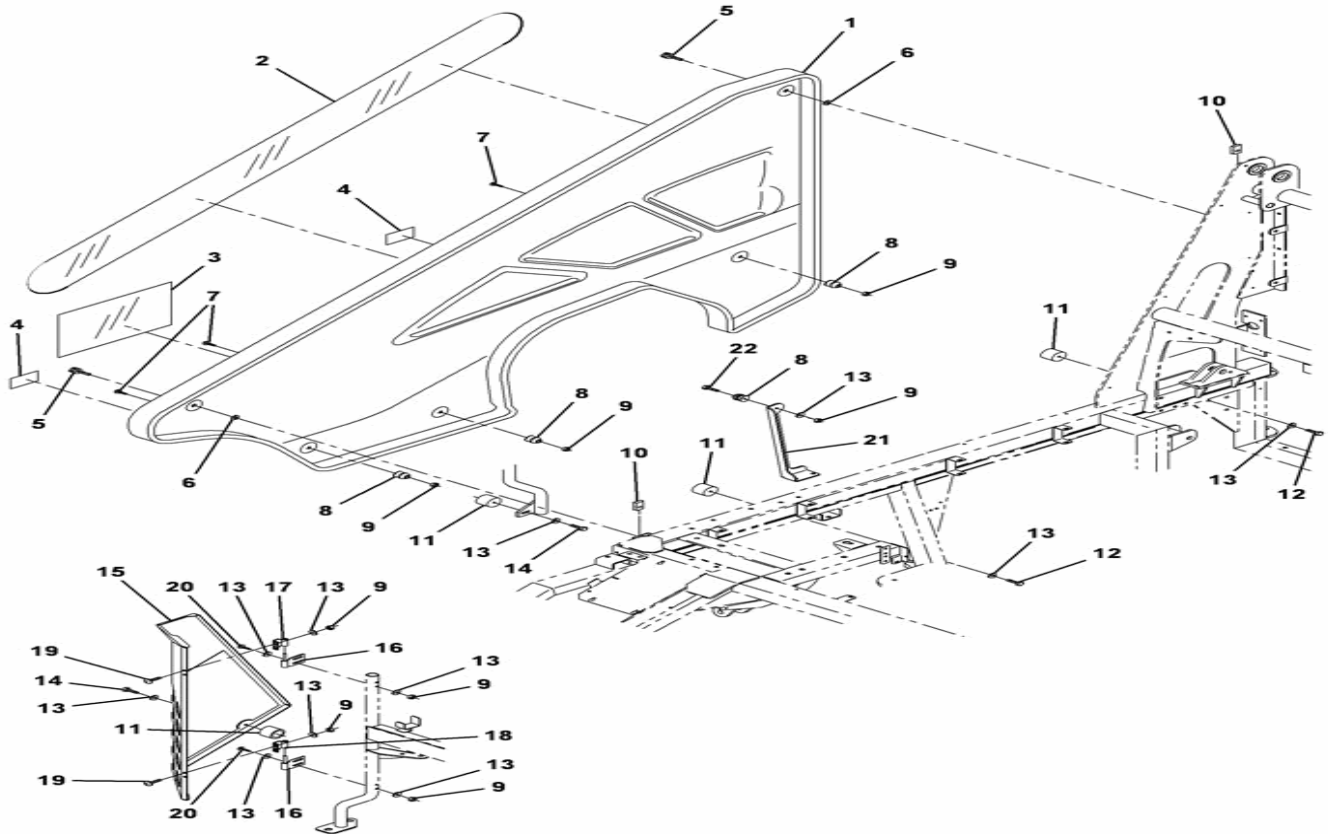

1	CP233 - CP233 - Side Panel,Right Hand with De	1
2	GM505 - Decal, Side Panel Green/White	1
3	GM517 - Decal, Side Panel Green/White	1
4	GM451 - Tyre Pressure Label - 636	2
5	GG146 - Knurled panel screw	2
6	GG148 - Retaining washer - plastic	2
7	GT338 - Screw,Button Head Hex Socket - M6 x 3	4
8	GG033 - Door Stop - male	4
10	GG147 - Slip on receptacle	2
11	GG044 - Door Stop - female	4
15	CD087 - CD087 - Access Door,Right Hand,Hinged	1
16	CD100 - Top/Bottom, Right Hand Frame Hinge	2
17	CD103 - Top Right Hand Door Hinge	1
18	CD106 - Bottom Right Hand Door Hinge	1
19	GT320 - Screw, Button Head Hex Socket - M6 x	4
20	GT338 - Screw,Button Head Hex Socket - M6 x 3	4
21	CD099 - Bracket, Access Door	1

Special Tools and Schematic Drawings - 636HS

Model: **636HS Green Machine**
 From CIN: **1** To CIN: **12**
 Drawing: **636099-8** Revision:

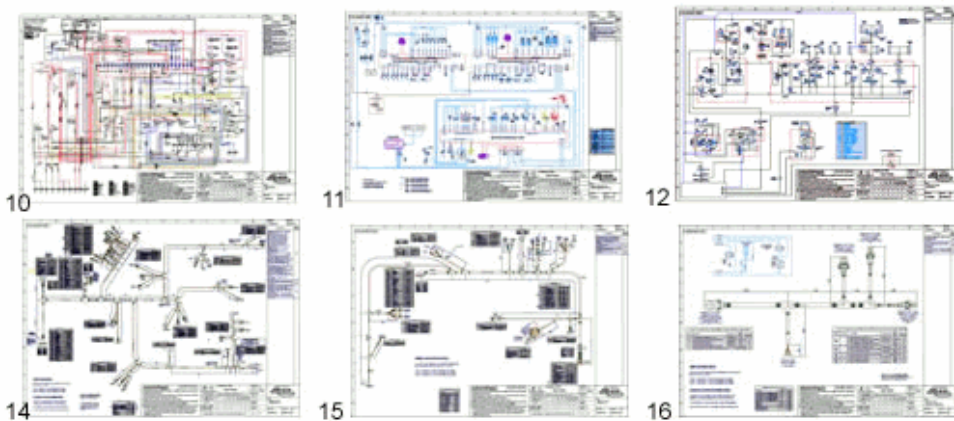

636099-8

Shows special tools and large scale schematic drawings that are available to help with servicing of 636HS.

1	AT020 - Hose Burst Valve Tool	1
2	JG006 - Bushing Replacement Tool	1
3	EW193 - Solenoid Test Loom	1
4	EW197 - Solenoid Test Loom	1
5	AT023 - Wear Gauge - 45mm x 2.0mm	1
6	AT024 - Wear Gauge - 105mm x 1.5mm	1
7	GG287 - Fan Inspection Door Key	1
10	ED013 - Electrical Diagram - 636HS	1
11	ED014 - IQAN Electronic Control Schematic Dia	1
12	HD005 - Hydraulic Circuit Diagram - 636HS	1
14	EW212DWG - Chassis IQAN Wiring Loom Drawing - 6	1
15	EW213DWG - Cab IQAN Wiring Loom Drawing	1
16	EW214DWG - Drawing of IQAN Wiring Loom - Vacuum	1

Hopper and Dump Door

Model: **636HS Green Machine**
 From CIN: **13** To CIN: **999**
 Drawing: **354837** Revision: **00**

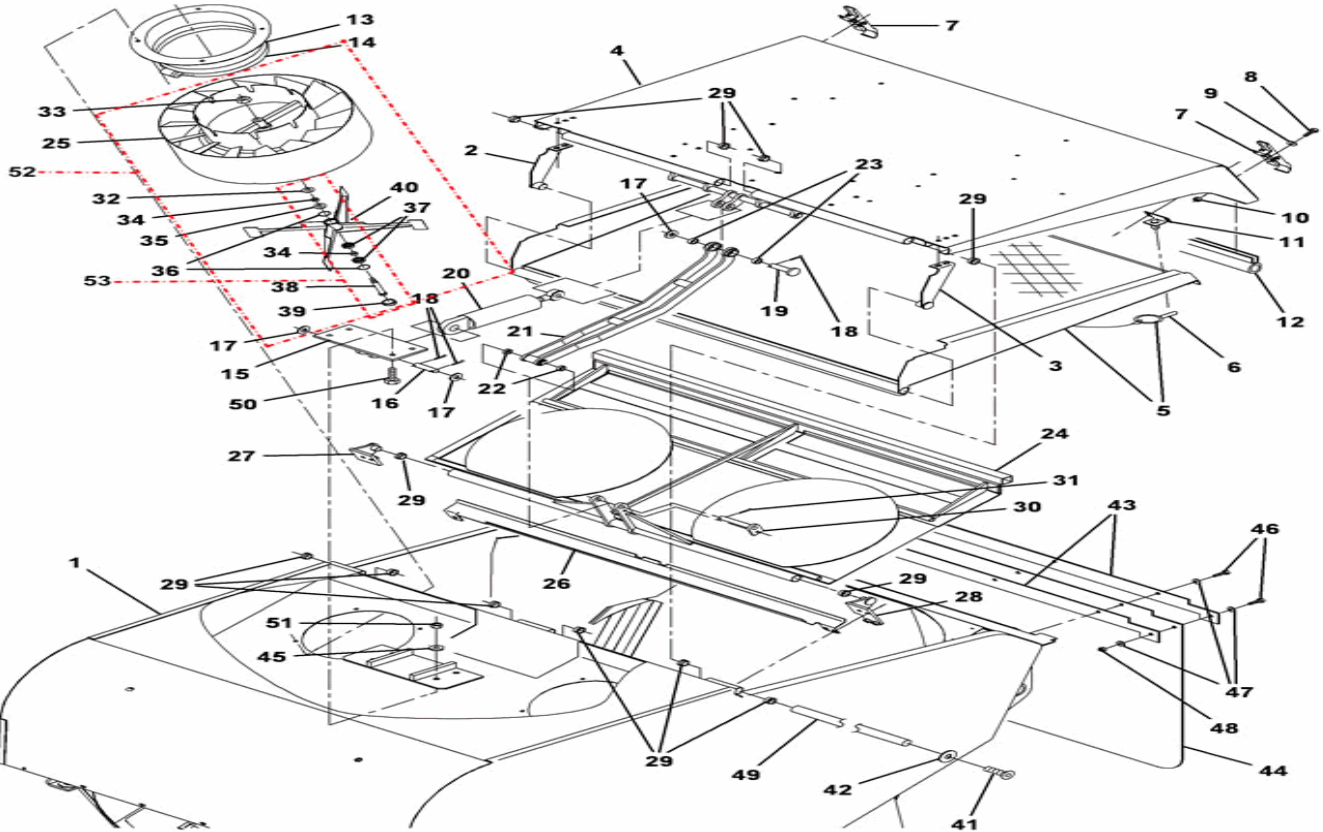

1	VH408 - Hopper Body Weldment	1	22	GB031 - Bush, Flanged DU - 12 I/D x 14 O/D x	2
2	VH122 - Hinge Plate RH - Rear Door	1	23	GB099 - Bush, Flanged DU - 20 I/D x 23 O/D x	2
3	VH125 - Hinge Plate LH - Rear Door	1	24	VH410 - Mesh Door,Cyclones	1
4	VH409 - Hopper Door	1	25	VH259 - Hopper Cyclone Body	2
5	VH540 - Rear Mesh Door	1	26	VH639 - Closing Plate,Cyclones	1
6	VH181 - Lynch Pin Assembly - Hopper	2	27	VH296 - Hinge Bracket - Right Hand (Hopper)	1
7	GG156 - Adjustable Latch	2	28	VH453 - Mesh Door Bracket	1
8	GT386 - Screw, Skt hd. M5 x 16 st st	6	29	GB093 - Bush	2
11	VH216 - Mounting Plate - Hopper	2	30	VH251 - Pin, Hydraulic Cylinder	1
12	GM391 - Hopper Door Seal	1	31	GG177 - Pin,Split - 1/8" DIA x 1 1/4" LON	1
13	VH536 - Sleeve,Cyclone	2	32	GW079 - M10 Washer - Form A (Stainless Steel)	1
14	GG277 - Clamp, Heavy Duty	2	33	GN069 - M8 Locknut - Nylon (Stainless Steel)	1
15	VH610 - Clevis Plate	1	34	VH272 - Spinner Spacer (Cyclone)	2
16	VH142 - Pin, Door Hydraulic Cylinder	1	35	GM401 - Felt Washer - 22 O/D x 10.5 I/D	1
17	GW077 - M20 Washer - Form A (Stainless Steel)	3	36	GG276 - Internal Circlip 22 mm bore	2
18	GG249 - Pin ,Split1 1/2" x 1/8"	3	37	GB100 - Bearing, Single Row	2
19	VH253 - Pin, Hydraulic Cylinder	1	38	VH271 - Spinner Shaft Bearing (Cyclone)	1
20	HC148 - Hydraulic Cylinder, Hopper Roof	1	39	GM399 - Blanking Plug	1
21	VH516 - Pivot Arm-Cyclone Mesh Door	1	40	VH273 - Cyclone Spinner	1

Hopper and Dump Door

Model: 636HS Green Machine
 From CIN: 13 To CIN: 999
 Drawing: 354837 Revision: 00

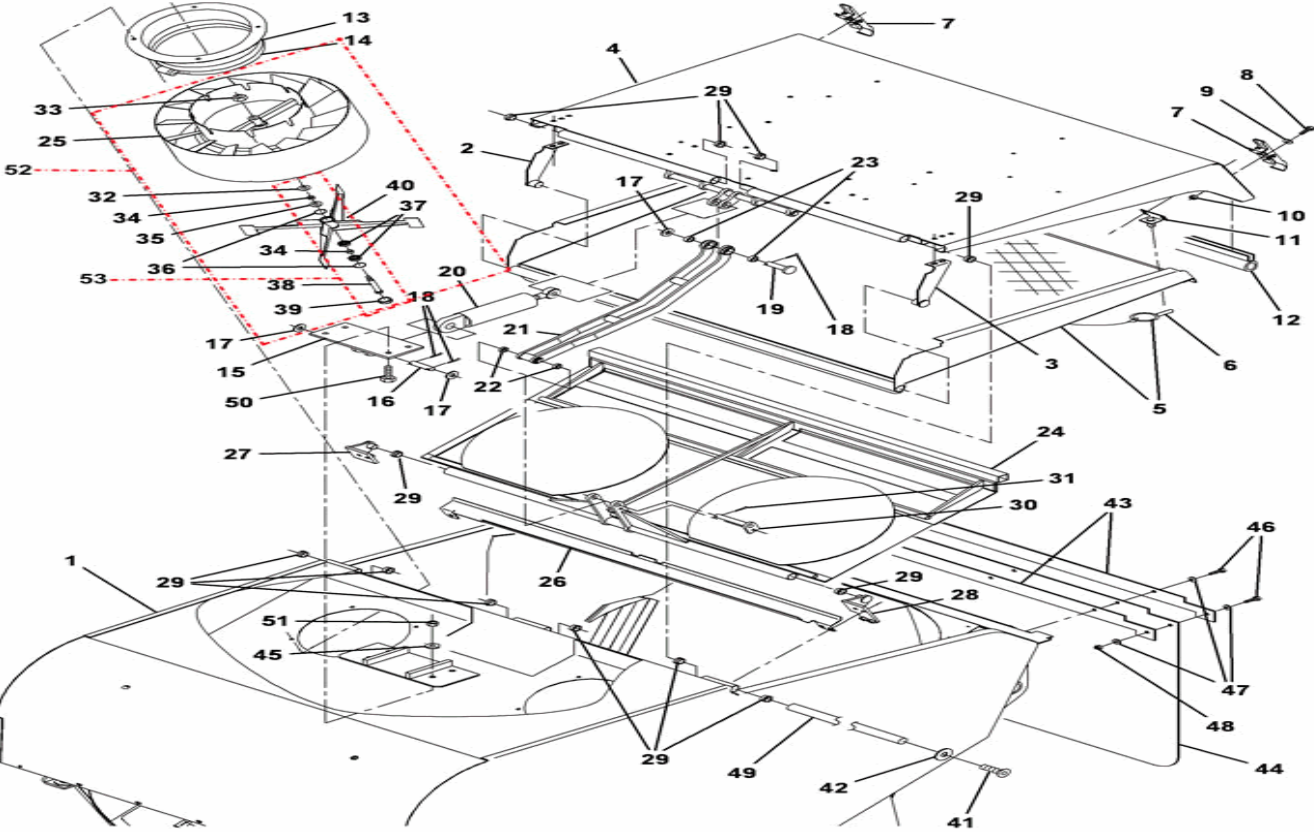

43	VH163 - Rubber Aprons Retaining Plates	2
44	VH164 - Rubber Apron	1
49	VH204 - Hopper Door Pin	1
52	VH274 - Cyclone Assembly Complete	2
53	VH373 - Cyclone Spinner Bearing Kit	2

Hopper Lift

Model: **636HS Green Machine**
 From CIN: **13** To CIN: **999**
 Drawing: **354838** Revision: **00**

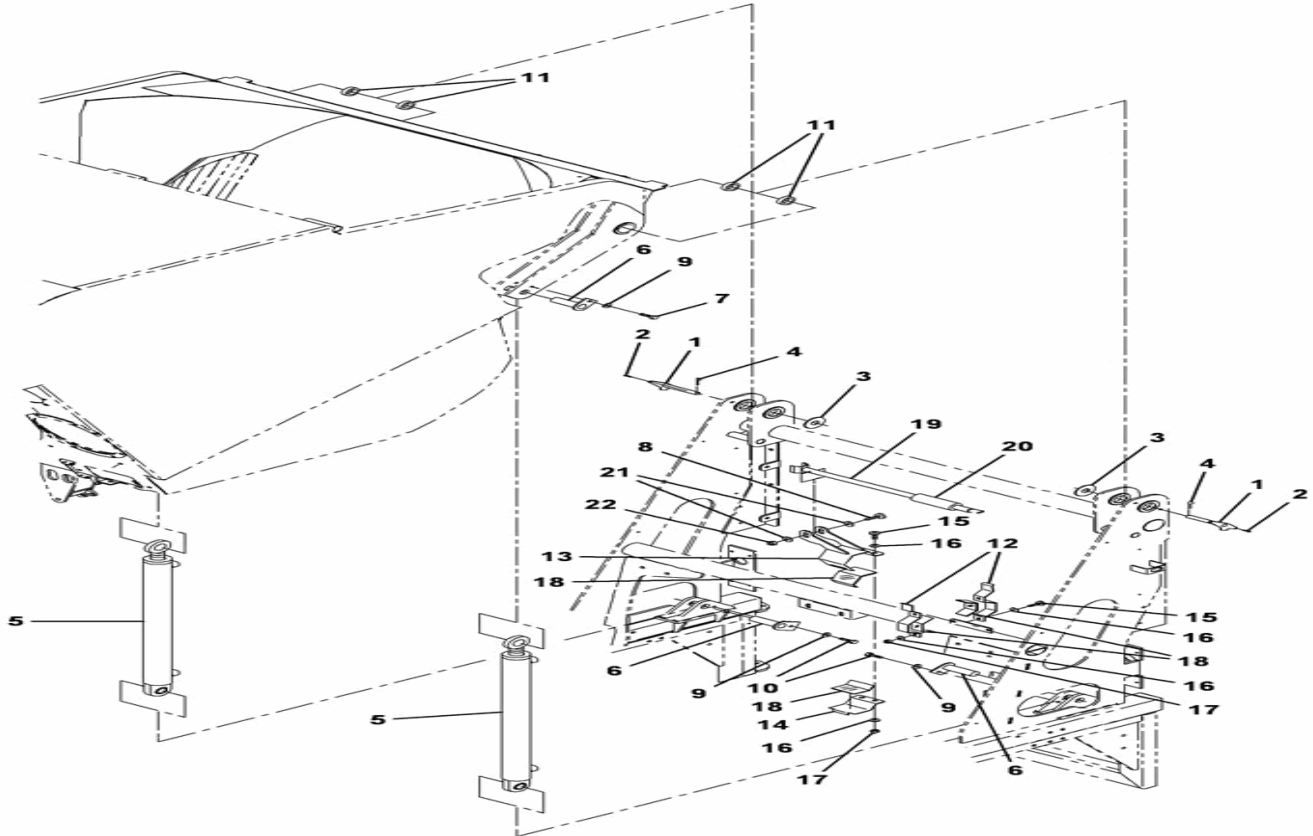

1	VH145 - Pin for Hopper, Chassis/Hopper	2
2	GT404 - Screw, Countersunkhead M8 x 16 Zinc P	4
3	GW078 - Washer M30	2
4	GG266 - Pin, Split - 4 x 32	2
5	HC141 - Hydraulic Cylinder, Hopper	2
6	VH143 - Pin Weldment, Top Hyd. Cylinder	4
8	GT347 - Screw - Button Head M8 x 80 ST.ST A4	1
11	GB092 - Bush, Hopper Pivot	4
12	CB902 - Parking Clamp, Hopper Stay	2
13	CB898 - Mounting Bracket, Hopper Stay	1
15	GT327 - M6 x 16 Stainless Steel Button Head	4
18	GM562 - Rubber Gripper Hopper Safety Stay Bra	4
19	CB894 - Hopper Stay Weldment	1
20	GM561 - Foam, Grip Hopper Stay	1

Hydraulic System - Auxiliary Cylinder Manifold

Model: 636HS Green Machine
 From CIN: 1 To CIN: 12
 Drawing: 636050-8 Revision:

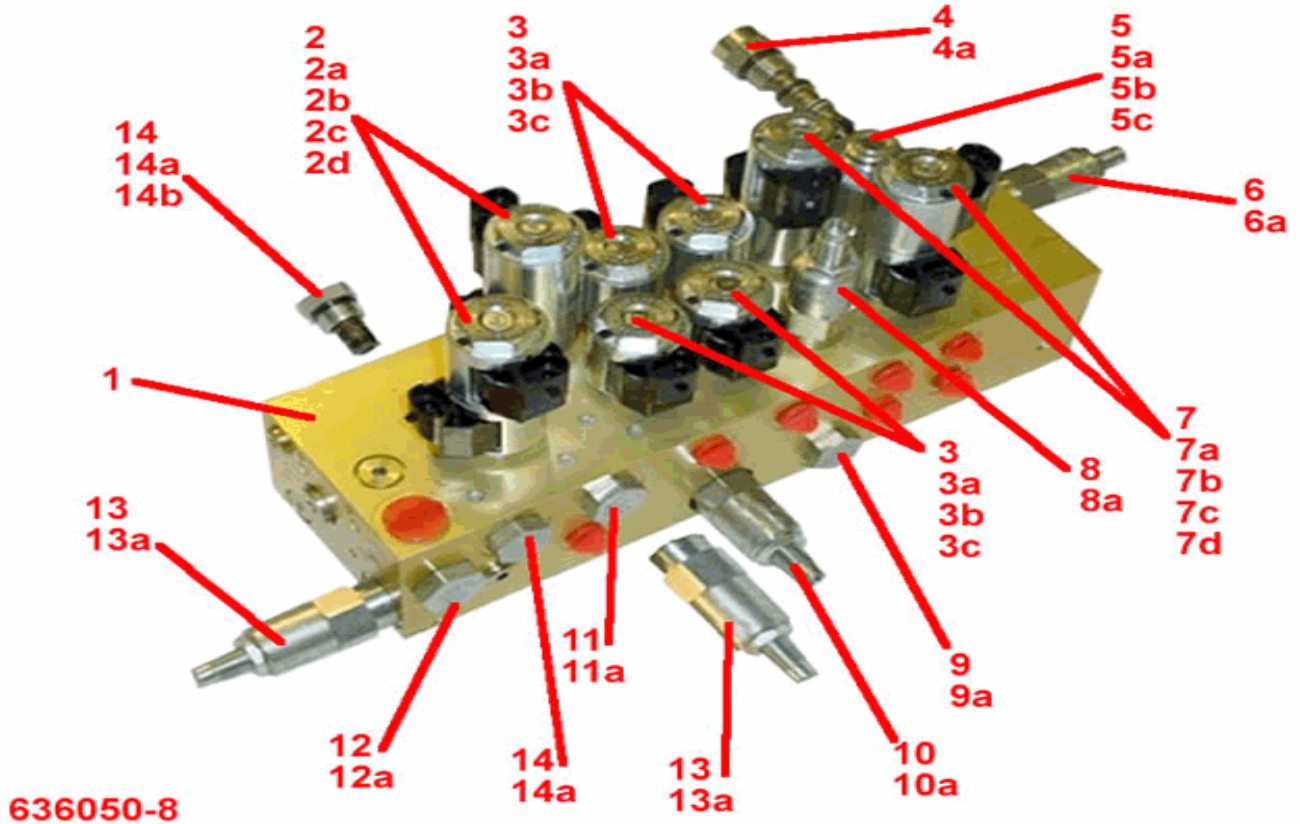

636050-8

1	HC158 - Hydraulic Block Assy. - Cylinders	1	7a	HV174 - Coil, EYZ Type for SV08	2
2	HV111 - Solenoid Valve	2	7b	HV125 - Coil Spacer for twin coil valves	2
2a	HV174 - Coil, EYZ Type for SV08	2	7c	HV122 - E Coil Nut	2
2b	HV125 - Coil Spacer for twin coil valves	2	7d	HV104 - Seal Kit for HV111	2
2c	HV122 - E Coil Nut	2	8	HV115 - Relief Valve - 50 bar	1
2d	HV104 - Seal Kit for HV111	2	8a	HV045 - Seal Kit	1
3	HV108 - Solenoid Valve	4	9	HV106 - Shuttle Valve	1
3a	HV174 - Coil, EYZ Type for SV08	4	9a	HV107 - Seal Kit for HV106	1
3b	HV122 - E Coil Nut	4	10	HV137 - Pressure Reducing Valve	1
3c	HV051 - Seal Kit	4	10a	HV110 - Seal Kit	1
4	HV039 - Valve, priority flow	1	11	HV112 - P.O. Check Valve	1
4a	HV139 - Seal Kit	1	11a	HV113 - Seal Kit for HV112	1
5	HV102 - Solenoid Valve	1	12	HV116 - Check Valve	1
5a	HV174 - Coil, EYZ Type for SV08	1	12a	HV096 - Seal Kit for HV116, HV095 & HV097	1
5b	HV124 - E-Coil Nut for SV08	1	13	HV208 - Relief Valve - 115 bar	2
5c	HV045 - Seal Kit	1	13a	HV045 - Seal Kit	2
6	HV101 - Relief Valve - 210 bar	1	14	HV062 - Valve, Check	2
6a	HV045 - Seal Kit	1	14a	HV120 - Double Pilot Piston	2
7	HV103 - Solenoid Valve	2	14b	HV045 - Seal Kit	2

Hydraulic System - Auxiliary Motor Manifold

Model: 636HS Green Machine
From CIN: 1 To CIN: 12
Drawing: 636051-8 Revision:

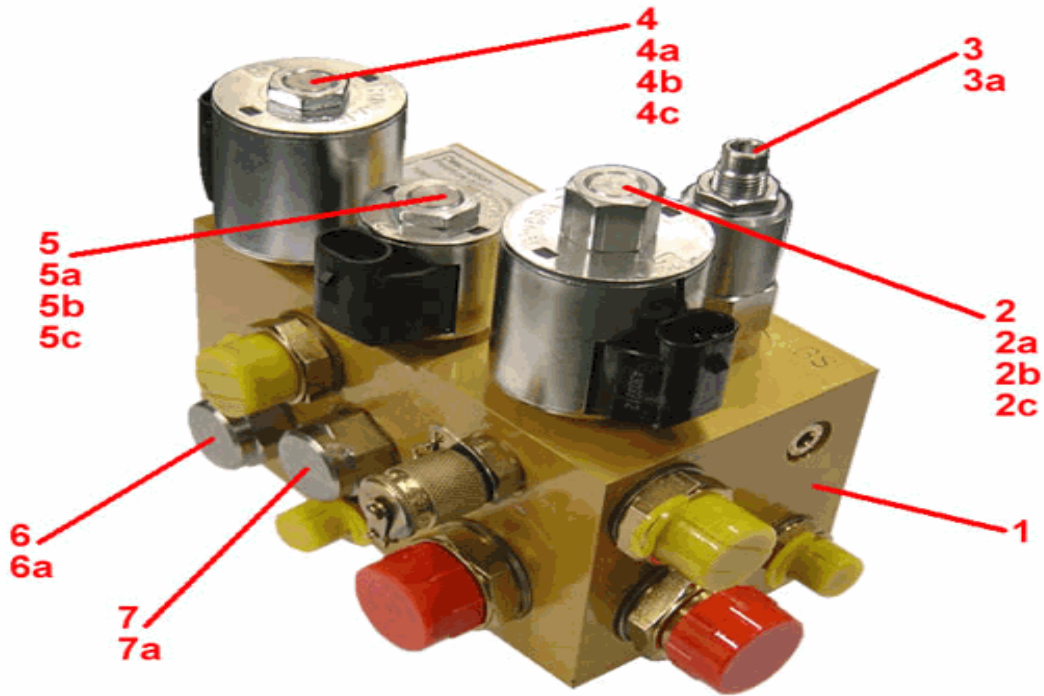

636051-8

1	HC182 - Hydraulic Block Assembly, Motor Manif	1
2	HV095 - Solenoid Valve	1
2a	HV175 - Coil, EYZ Type for SV10 & SV58	1
2b	HV142 - E Coil Nut	1
2c	HV140 - Seal Kit, Solenoid Valve	1
3	HV170 - Valve, Relief - High Pressure - 250 b	1
3a	HV171 - Seal Kit, Relief Valve	1
4	HV173 - Valve, Proportional Solenoid - SP10	1
4a	HV175 - Coil, EYZ Type for SV10 & SV58	1
4b	HV122 - E Coil Nut	1
4c	HV140 - Seal Kit, Solenoid Valve	1
5	HV172 - Valve, Proportional Solenoid - SP08	1
5a	HV174 - Coil, EYZ Type for SV08	1
5b	HV122 - E Coil Nut	1
5c	HV045 - Seal Kit	1
6	HV167 - Valve, Pressure Compensator - 80 SPRG	1
6a	HV169 - Seal Kit, Pressure Compensator Valve	1
7	HV168 - Valve, Pressure Compensator - 220 SPR	1
7a	HV169 - Seal Kit, Pressure Compensator Valve	1

Hydraulic System - Brush Cylinders

Model: 636HS Green Machine
From CIN: 1 To CIN: 12
Drawing: 636056-8 Revision:

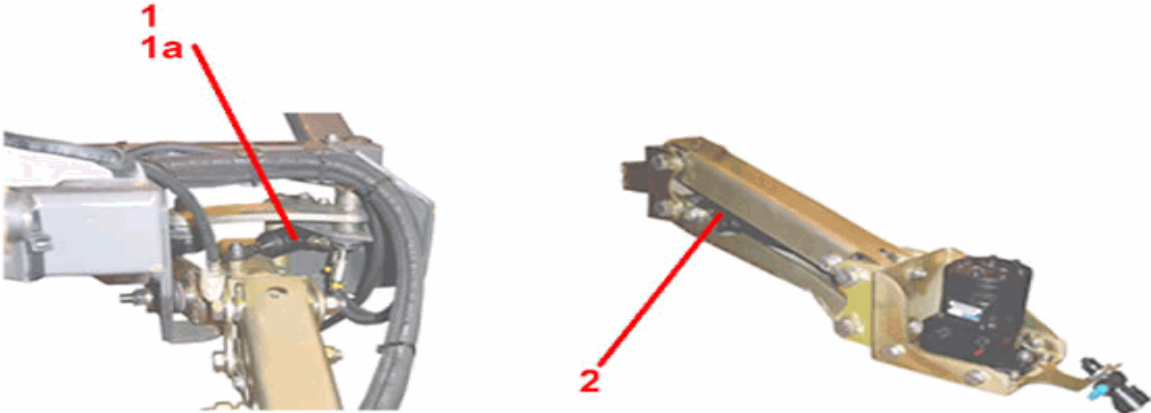

636056-8

1	HC143 - Hydraulic Cylinder, Brush In/Out	2
1a	HC144 - Seal Kit for HC143	1
2	HC160 - Hydraulic Cylinder - Brush Up/Down	1

Hydraulic System - Brush Height

Model: 636HS Green Machine
From CIN: 1 To CIN: 12
Drawing: 636061-8 Revision:

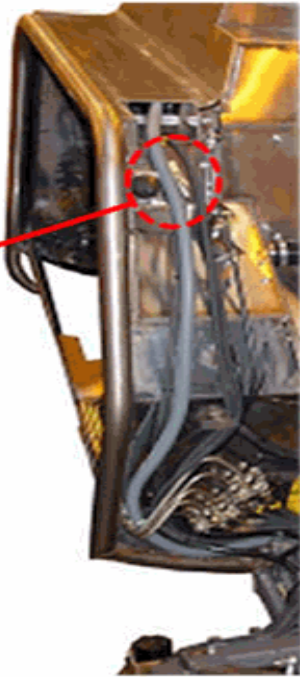
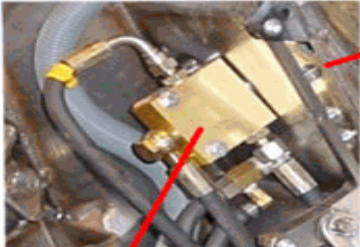

1

636061-8

Hydraulic System - Fan & Brush Motors

Model: 636HS Green Machine
 From CIN: 1 To CIN: 12
 Drawing: 636064-8 Revision:

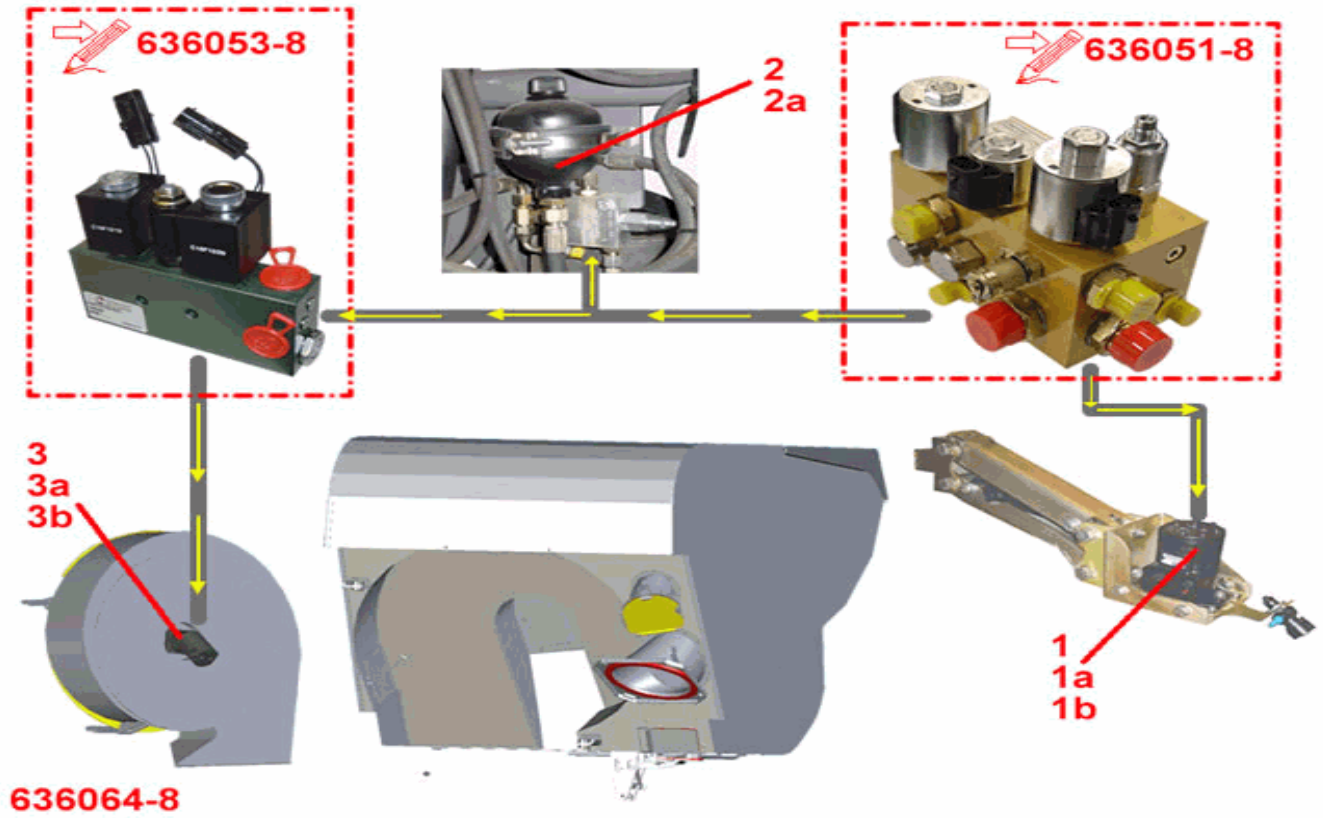

1	HM029 - Hydraulic Drive Motor, T Type 60cc	2
1a	HM037 - Key for Brush Motor	2
1b	HM021 - Seal Kit, Hyd. Motor	2
2	HV090 - Accumulator	1
2a	CB839 - Accumulator Clamp Assembly	1
3	HM050 - Motor, Fan Drive - 12cc	1
3a	HM053 - Seal Kit for Fan Motor (12cc)	1
3b	HM054 - Key for Fan Motor (12cc)	1

Hydraulic System - Hopper & Brush Valve

Model: 636HS Green Machine
From CIN: 1 To CIN: 12
Drawing: 636060-8 Revision:

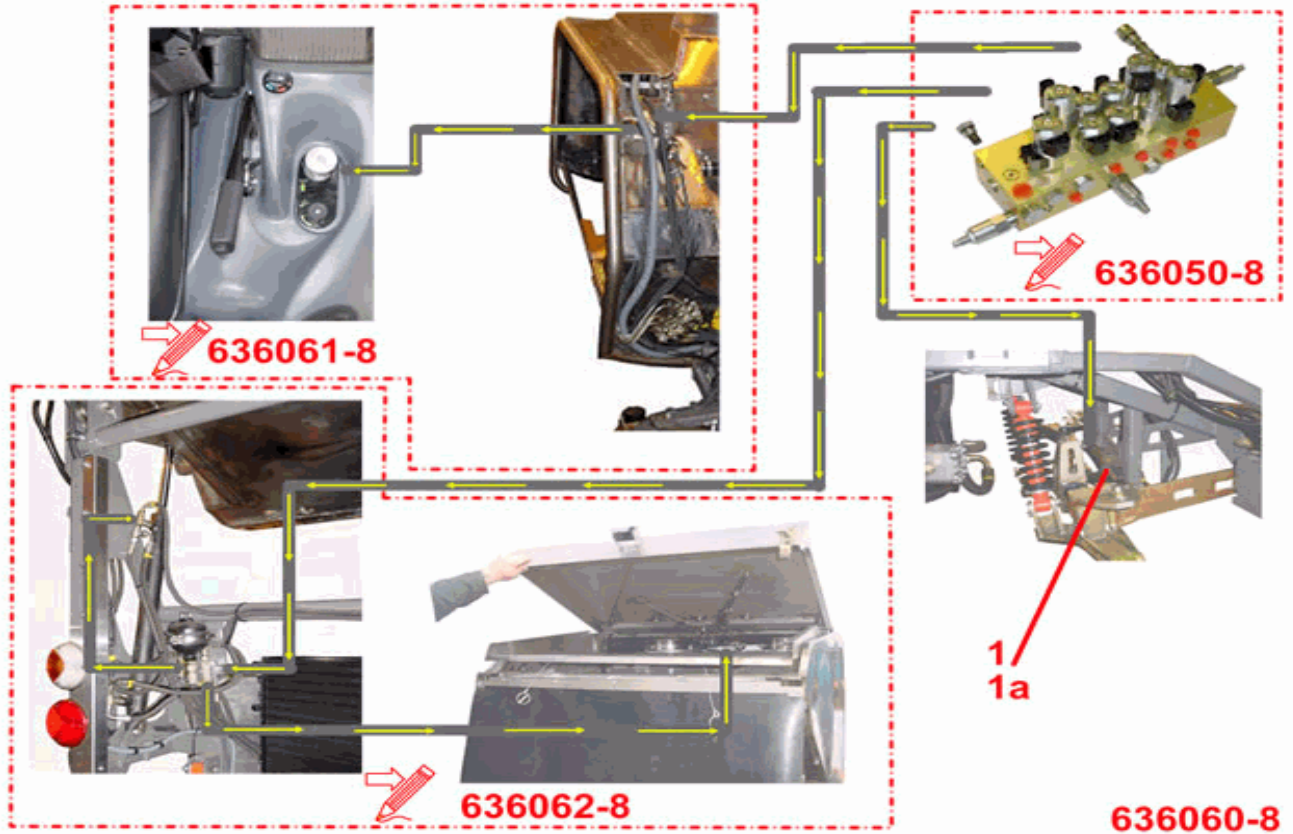

1	HC187 - HC187 - Hydraulic Cylinder - Tracking	2
1a	HC140 - Seal Kit for HC138, HC148 & HC165	2

Hydraulic System - Hopper Cylinders

Model: **636HS Green Machine**
 From CIN: **1** To CIN: **12**
 Drawing: **636062-8** Revision:

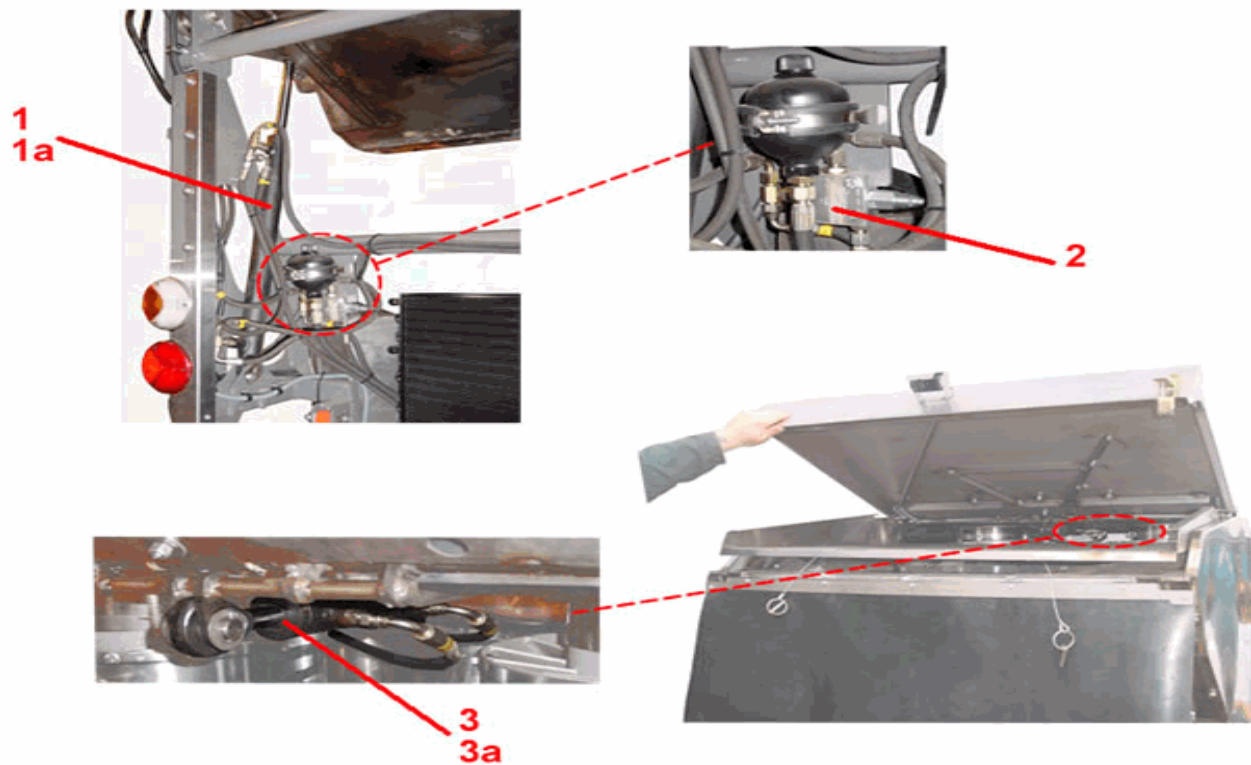

636062-8

1	HC141 - Hydraulic Cylinder, Hopper	2
1a	HC142 - Seal Kit for HC141	1
2	HV119 - Sequence Valve, Direct Acting	1
3	HC148 - Hydraulic Cylinder, Hopper Roof	1
3a	HC140 - Seal Kit for HC138, HC148 & HC165	1

HF092 Bulkhead Fittings2
 HJ280 Rod End Hose1
 HJ279 Cap End Hose1

Hydraulic System - Hopper Manifold

Model: **636HS Green Machine**
 From CIN: **1** To CIN: **12**
 Drawing: **636053-8** Revision:



636053-8

1	HC189 - Hydraulic Block Assembly, Hopper Mani	1
2	HV193 - Valve, Check - 3CA80	1
2a	HV194 - Seal Kit for 3CA80 Check Valve	1
3	HV190 - Valve, Solenoid - S229N	1
3a	HV191 - Coil, for S229N Valve	1
3b	HV192 - Seal Kit for S229N Valve	1
3c	HV196 - Coil Nut S229N Valve	1
4	HV187 - Valve, Solenoid - 2 way - S502N	1
4a	HV188 - Coil, For S5 Valves	1
4b	HV189 - Seal Kit for S5 Solenoid Valve	1
4c	HV195 - Coil Nut, for S5 Valve	1
5	HV185 - Valve, Relief - 210 bar	1
5a	HV186 - Seal Kit for Relief Valve (HV185)	1

Hydraulic System - Hydraulic Cylinder & Hand Pump

Model: 636HS Green Machine
From CIN: 1 To CIN: 12
Drawing: 636055-8 Revision:

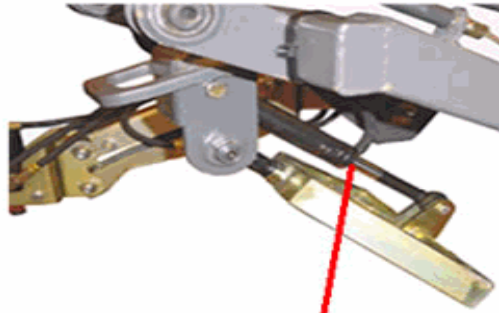
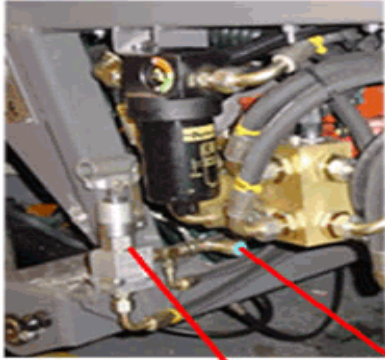

636055-8

1	HV131 - Hand Pump Valve	1
2	HC145 - Hyd. Cylinder, Nozzle Up/Down	1
2a	HC146 - Seal Kit for HC145	1
3	HV136 - Valve, In-line Needle - 1/4	1

Hydraulic System - Hydraulic Cylinders

Model: **636HS Green Machine**
From CIN: **1** To CIN: **12**
Drawing: **636054-8** Revision:

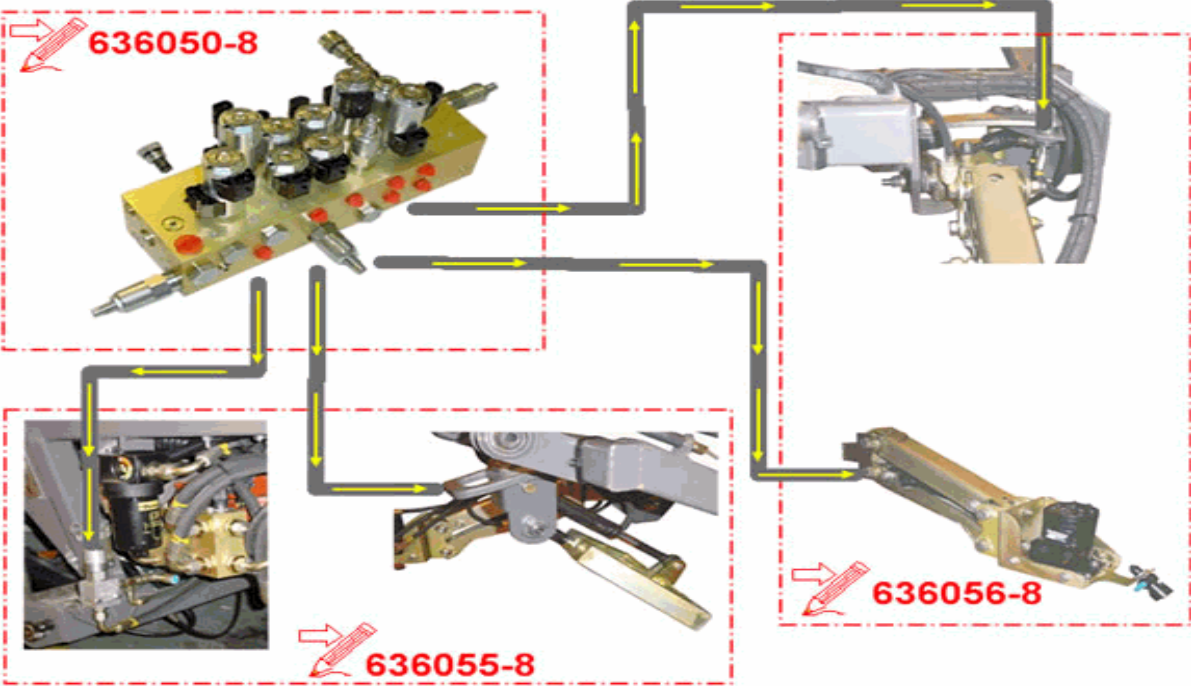

636054-8

Hydraulic System - Hydraulic Tank

Model: **636HS Green Machine**
 From CIN: **4** To CIN: **12**
 Drawing: **636104-1** Revision: **1**

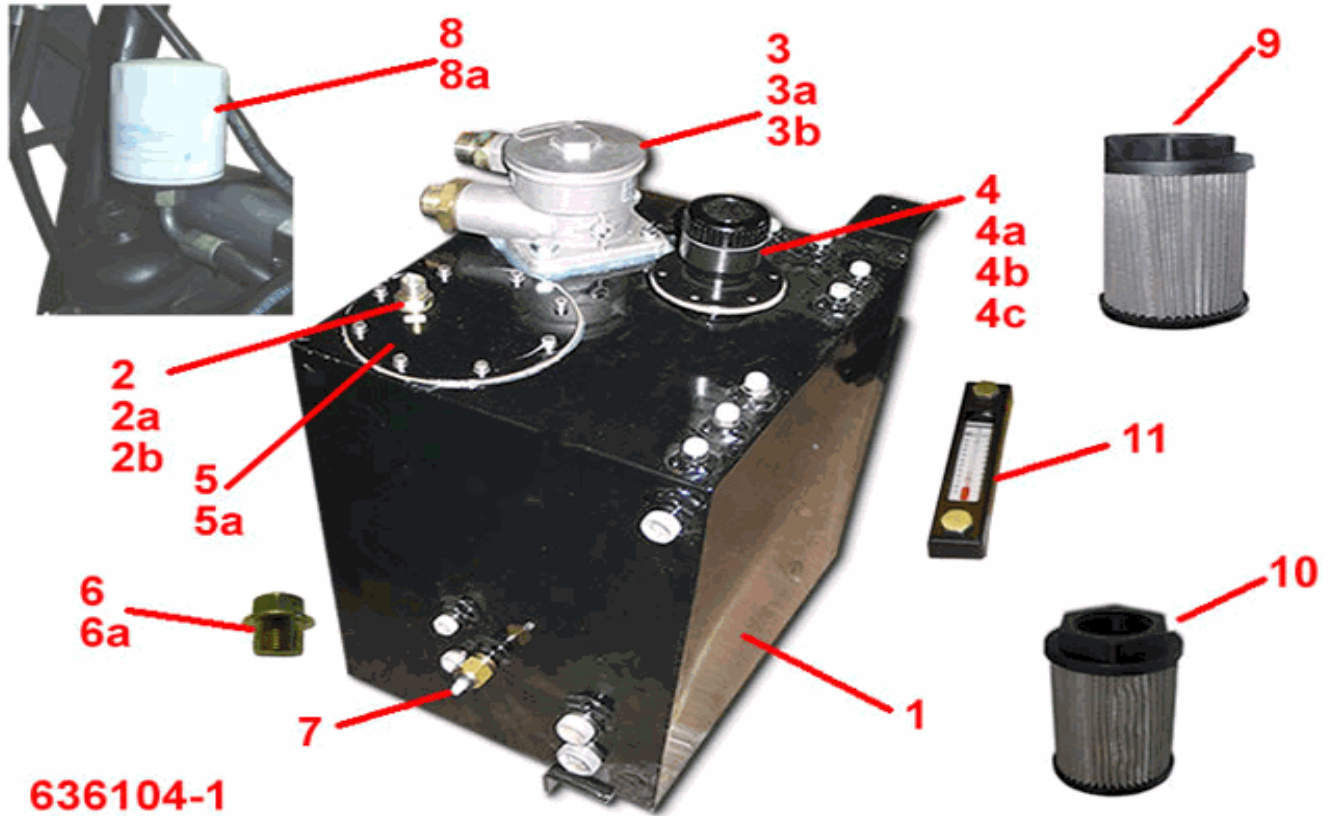

636104-1

1	HT064 - Hydraulic Tank	1	4b	HT088 - Filter, Filler Neck - Hydraulic Tank	1
1	HT064 - Hydraulic Tank	1	4c	HT082 - Cork Gasket, Hydraulic Tank	1
2	HF006 - Hydraulic Stud Coupling - 3/8 Male to	1	4c	HT082 - Cork Gasket, Hydraulic Tank	1
2	HF006 - Hydraulic Stud Coupling - 3/8 Male to	1	5	HT084 - Lid, Hydraulic Tank	1
2a	HF020 - Lock Nut, 3/8	1	5	HT084 - Lid, Hydraulic Tank	1
2a	HF020 - Lock Nut, 3/8	1	5a	HT050 - Gasket, Hydraulic Tank	1
2b	HF010 - Hydraulic Bonded Seal - 3/8 BSP (16mm	1	5a	HT050 - Gasket, Hydraulic Tank	1
2b	HF010 - Hydraulic Bonded Seal - 3/8 BSP (16mm	1	6	PD069 - Sump Plug	1
3	HC154 - Element - Filter , Suction & Return	1	6a	PD069 - Sump Plug	1
3	HC200 - Element - Filter , Suction & Return	1	6a	PD053 - Gasket, Sump Plug	1
3a	HC151 - Filter - Assembly , Suction & Return	1	6a	PD053 - Gasket, Sump Plug	1
3a	HC199 - Filter - Assembly , Suction & Return	1	7	ES253 - Temperature Switch - Hydraulic Oil	1
3b	HC155 - Visual Indicator, Suction/Return Filt	1	7	ES253 - Temperature Switch - Hydraulic Oil	1
3b	HC155 - Visual Indicator, Suction/Return Filt	1	8	PD264 - Remote Breather, Hydraulic Tank	1
4	HF153 - Filler Cap, Hydraulic Tank	1	8	PD264 - Remote Breather, Hydraulic Tank	1
4	HF153 - Filler Cap, Hydraulic Tank	1	8a	CD184 - Remote Breather Bracket	1
4a	HT087 - Filler Neck, Hydraulic Tank	1	8a	CD184 - Remote Breather Bracket	1
4a	HT087 - Filler Neck, Hydraulic Tank	1	9	HC153 - Suction Strainer, Auxiliary Pump	1
4b	HT088 - Filter, Filler Neck - Hydraulic Tank	1	9	HC153 - Suction Strainer, Auxiliary Pump	1

Hydraulic System - Hydraulic Tank

Model: 636HS Green Machine
 From CIN: 1 To CIN: 3
 Drawing: 636057-8 Revision:

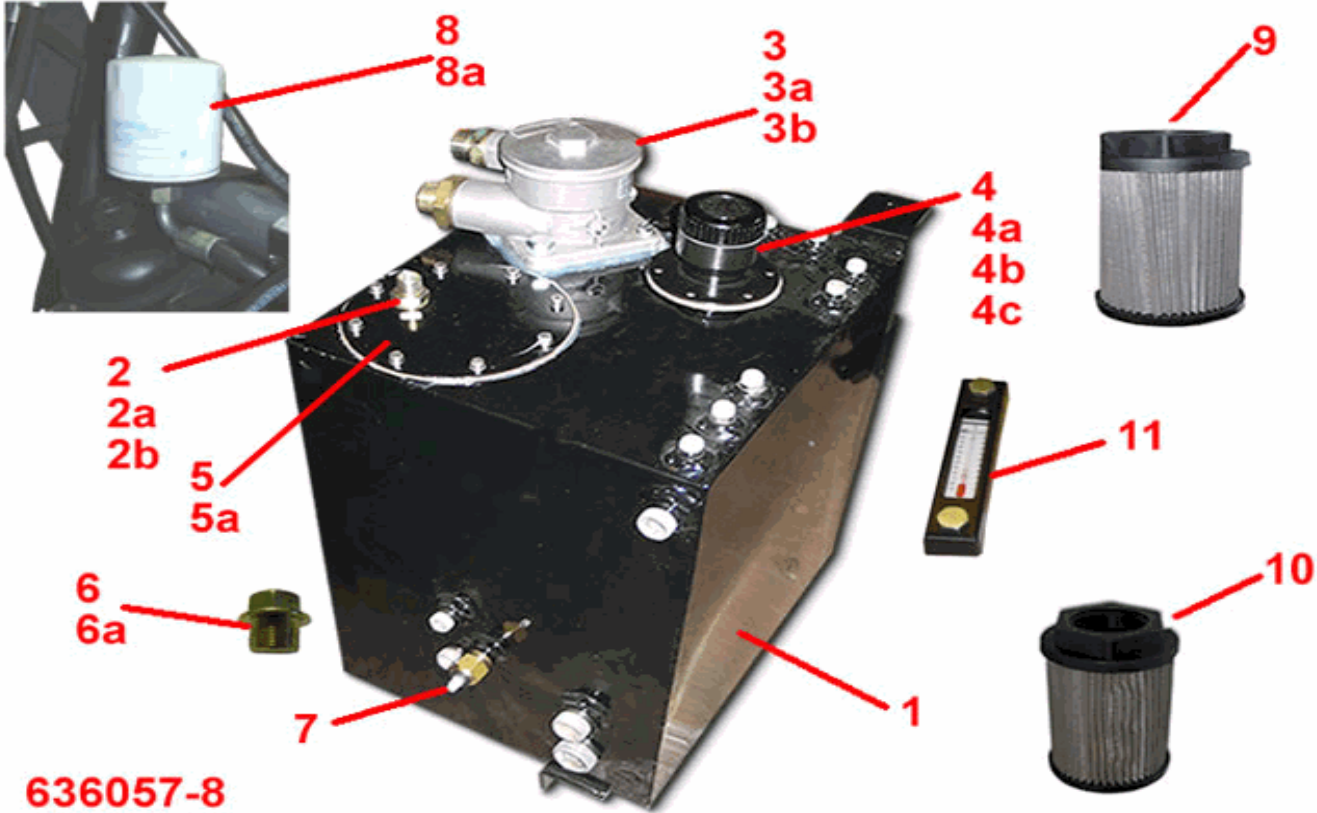

636057-8

10	HC152 - Suction Strainer, Steering Pump	1
10	HC152 - Suction Strainer, Steering Pump	1
11	HC156 - Oil Level/Temperature Gauge	1
11	HC156 - Oil Level/Temperature Gauge	1

Hydraulic System - Steering

Model: 636HS Green Machine
From CIN: 1 To CIN: 12
Drawing: 636058-8 Revision:

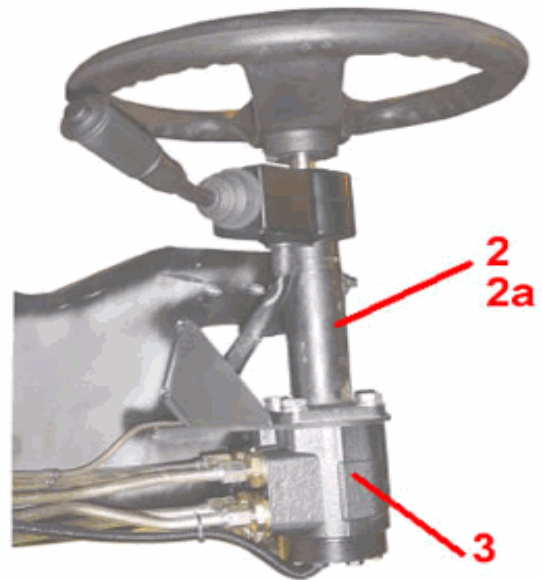
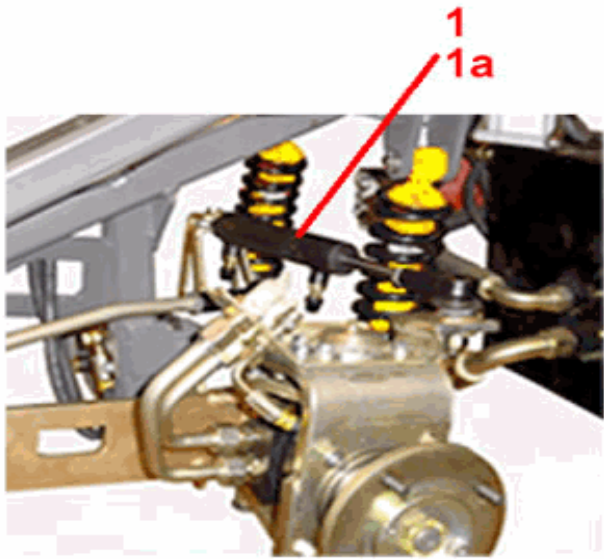

636058-8

1	HC137 - Hydraulic Cylinder - Steering	1
1a	HC139 - Seal Kit, Steering Cylinder	1
2	FS014 - Steering Column Assembly	1
2a	FS018 - Handle & Screw, Steering Column	1
3	HV138 - Steering Control Unit	1

Hydraulic System - Tanks, Pumps & Steering

Model: 636HS Green Machine
 From CIN: 3 To CIN: 12
 Drawing: 636108-1 Revision: a

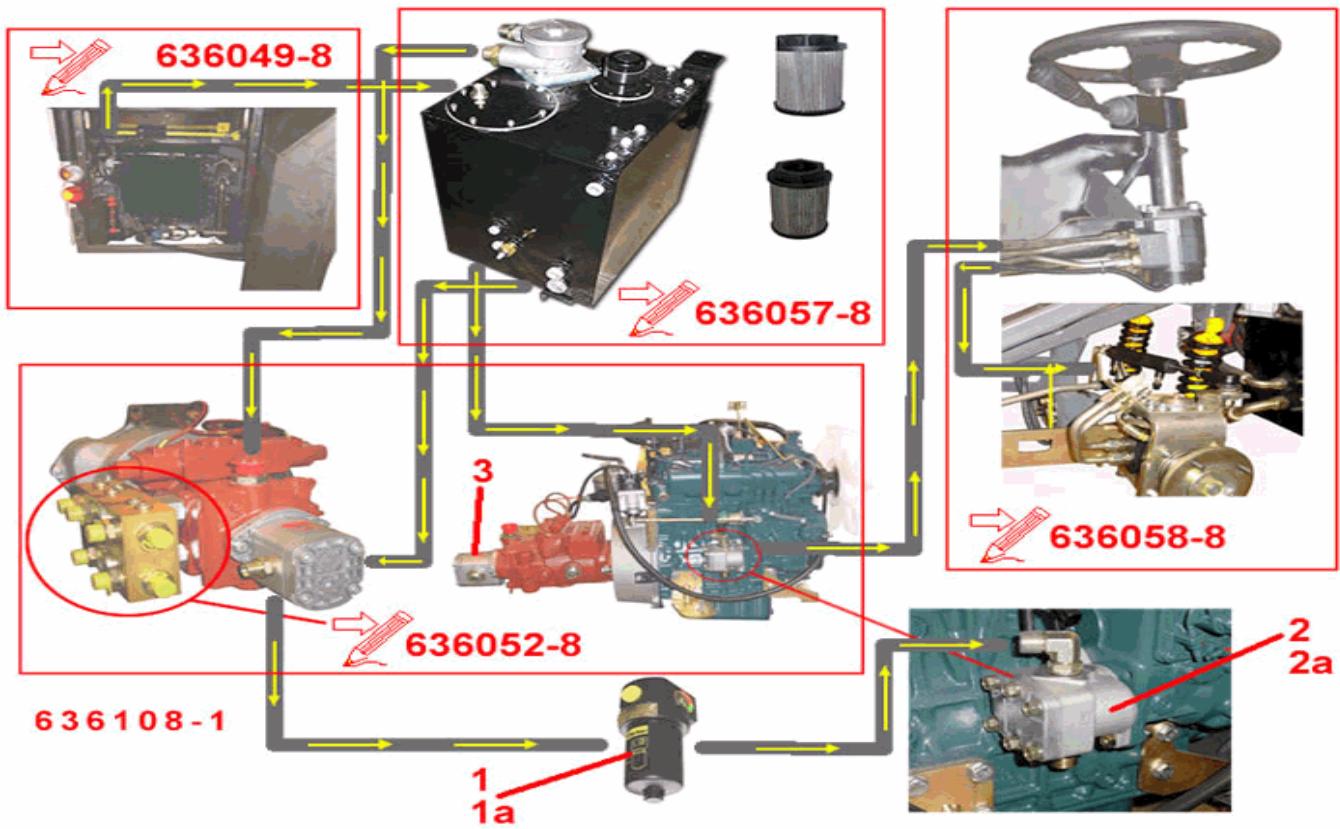

1	HC004 - Filter, Auxiliary Circuit Pressure	1
1	HC004 - Filter, Auxiliary Circuit Pressure	1
1a	HC058 - Filter Element	1
1a	HC058 - Filter Element	1
2	HP021 - Hydraulic Pump, Steering	1
2	HP021 - Hydraulic Pump, Steering	1
2a	HF105 - Adjustable Connector, 3/8 BSP 90 Deg	1
2a	HF105 - Adjustable Connector, 3/8 BSP 90 Deg	1
3	HP029 - Auxiliary Gear Pump - 19cc - 9 Tooth	1
3	HP033 - Auxiliary Gear Pump - 19cc - 11 Tooth	1
3a	HP033 - Auxiliary Gear Pump - 19cc - 11 Tooth	1

Hydraulic System - Transmission Manifold

Model: 636HS Green Machine
 From CIN: 1 To CIN: 12
 Drawing: 636052-8 Revision:

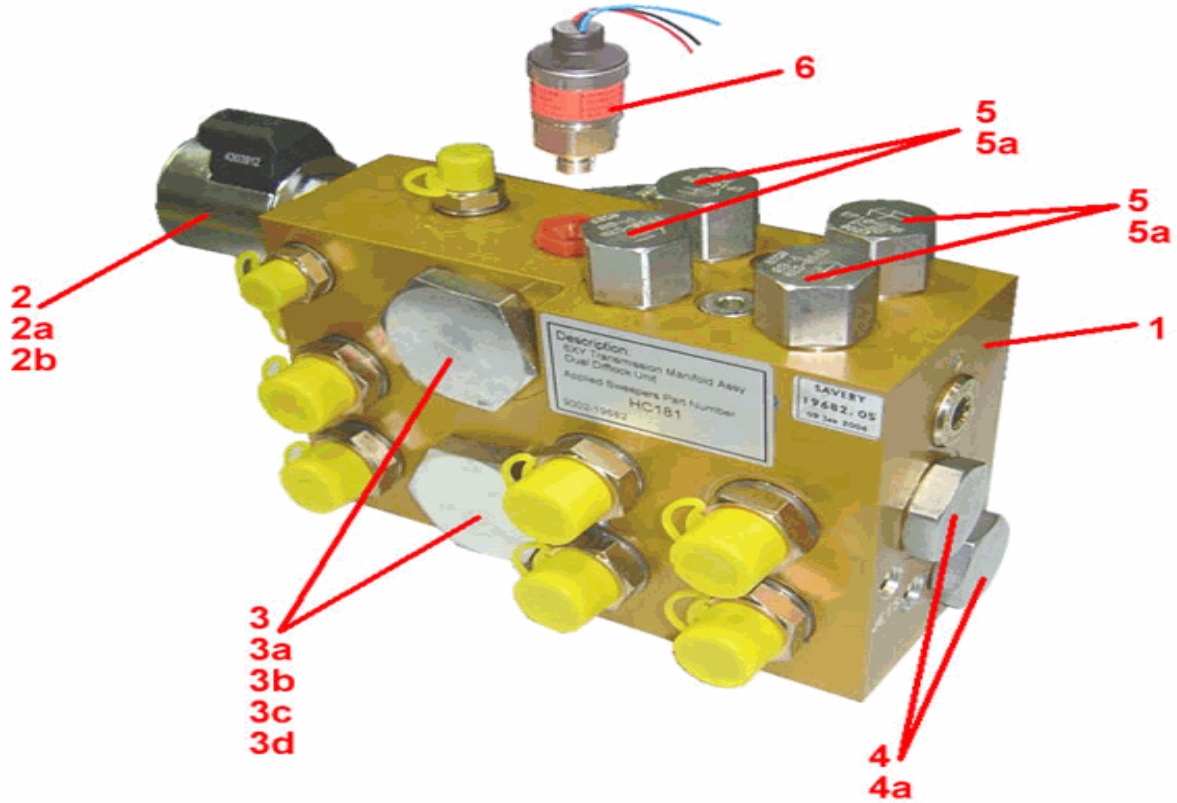

636052-8

1	HC181 - Hydraulic Block Assembly, Transmissio	1
2	HV182 - Valve, Spool - 3 Way - High Pressure	1
2a	HV123 - Coil, EY type for SV10 & SV58	1
2b	HV198 - Seal kit SK08	1
3	HF172 - Nut, Retaining - Manifold	2
3a	HF171 - Stud, Mounting - Manifold	2
3b	HF174 - O-Ring Kit, Mounting Studs - Manifold	1
3c	CD136 - Lock Clamp, Transmission Block	2
3d	CD135 - Lock Anchor, Transmission Block	1
4	HV184 - Flow Divider/Combiner	2
4a	HV118 - Seal Kit for HV117	1
5	HV181 - Valve, Logic Element	4
5a	HV199 - Seal Kit SK10	4
6	ES278 - Pressure Transducer c/w Plug	1

Hydraulic System - Wheel Motors

Model: **636HS Green Machine**
 From CIN: **1** To CIN: **12**
 Drawing: **636063-8** Revision:

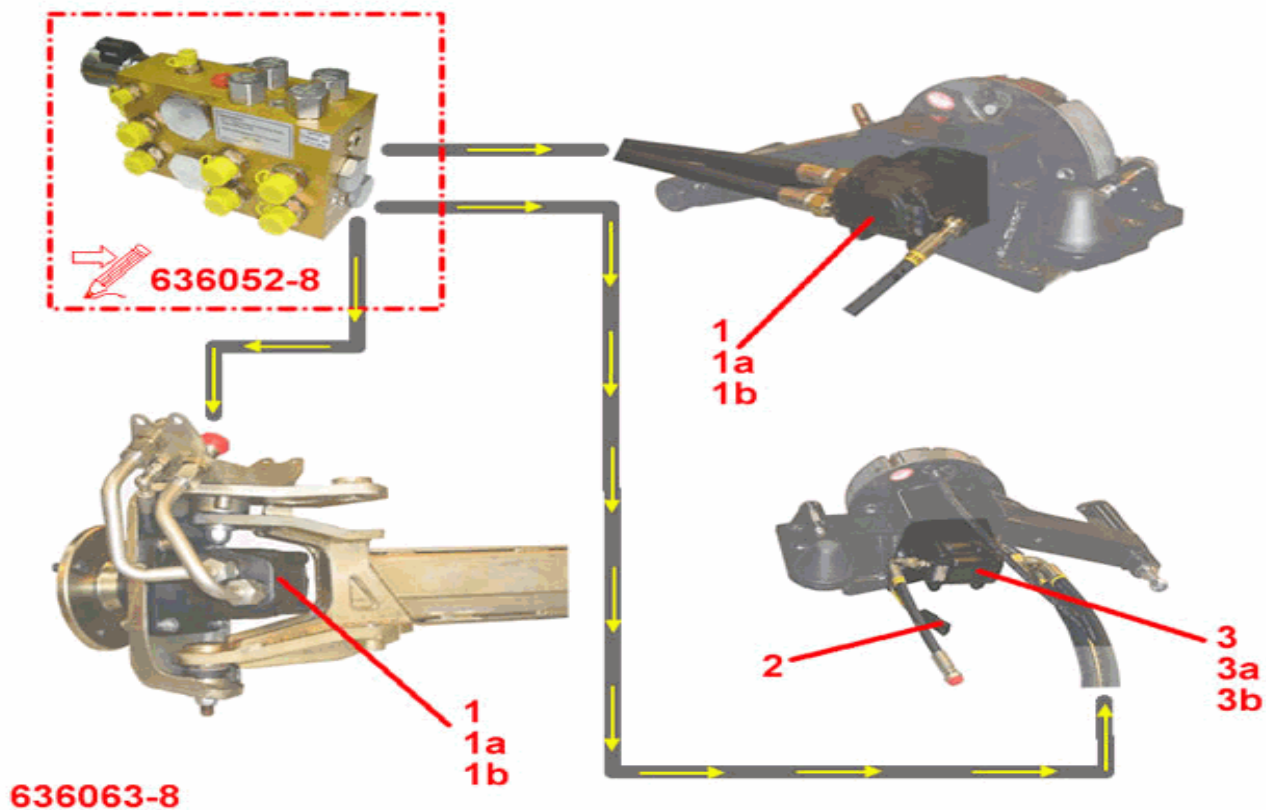

1	HM035 - Wheel Motor, 100cc	3
1a	HM031 - Key, Wheel Motor	3
1b	HM033 - Seal Kit, Wheel Motor	3
1c	HF077 - Adaptor - 1/2 to 1/2	2
2	ES285 - Speed Sensor, Wheel Motor with plug	1
3	HM052 - Wheel Motor, Left Side Rear 100 cc (w	1
3a	HM031 - Key, Wheel Motor	1
3b	HM033 - Seal Kit, Wheel Motor	1
3c	HF077 - Adaptor - 1/2 to 1/2	2

Pressure Washer - Hydraulic System (from CIN 2)

Model: 636HS Green Machine
From CIN: 2 To CIN: 12
Drawing: 636095-8 Revision:

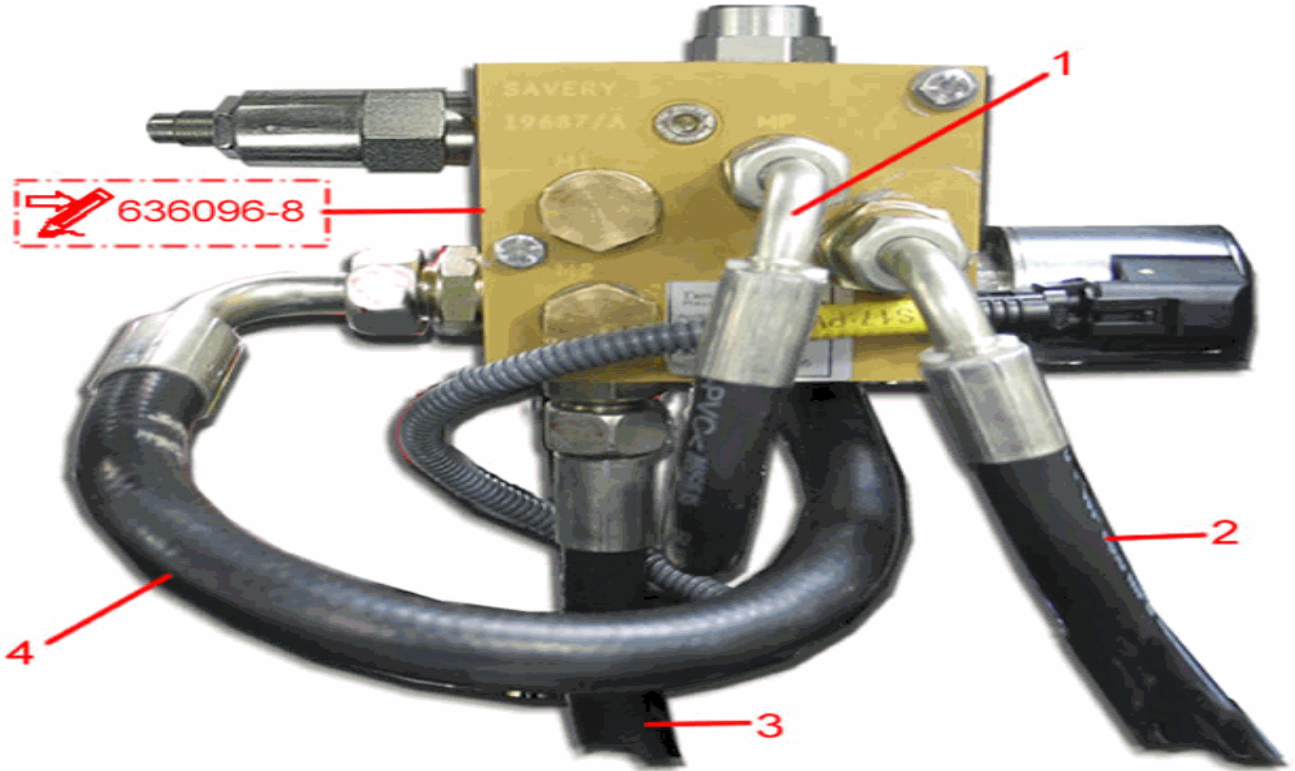

636095-8

1	HJ311 - Hydraulic Hose,Pressure Washer Manifo	1
2	HJ317 - Hydraulic Hose,Motor Manifold-Pressur	1
3	HJ319 - Hydraulic Hose,Pressure Washer Manifo	1
4	HJ314 - Hydraulic Hose,Pressure Washer Pump-P	1

Pressure Washer - Hydraulic System(to CIN 1)

Model: 636HS Green Machine
 From CIN: 1 To CIN: 1
 Drawing: 636093-8 Revision:

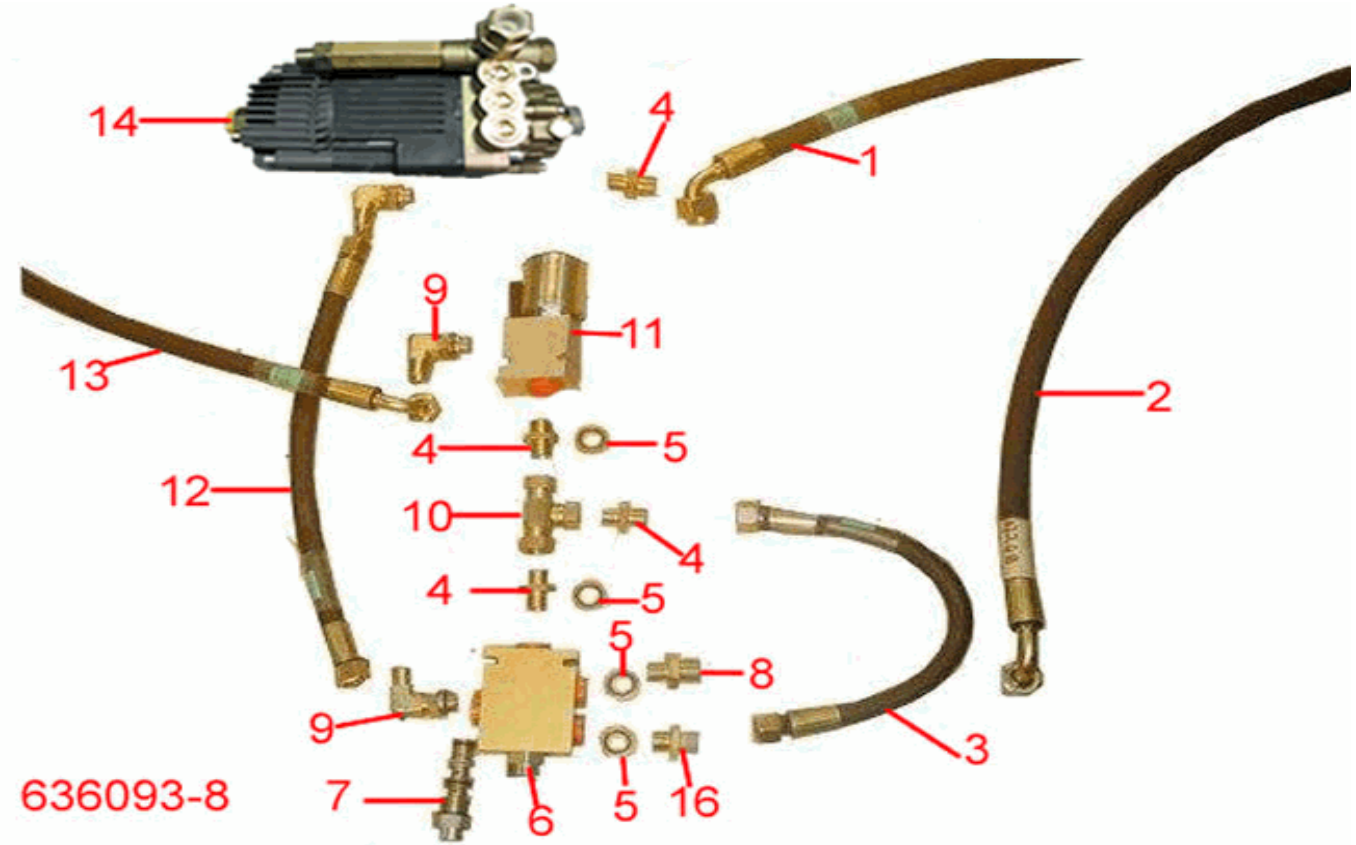

636093-8

1	HJ288 - Hydraulic Hose,Pressure Washer Pump R	1
2	HJ289 - Hydraulic Hose,Pressure Washer Valve	1
3	HJ290 - Hydraulic Hose,Loop On Pressure Washe	1
4	HF006 - Hydraulic Stud Coupling - 3/8 Male to	3
5	HF010 - Hydraulic Bonded Seal - 3/8 BSP (16mm	4
6	HV146 - Valve Block	1
7	HV039 - Valve, priority flow	1
8	HF017 - Hydraulic Adaptor Coupling - 1/2 Male	1
9	HF105 - Adjustable Connector, 3/8 BSP 90 Deg	2
10	HF052 - Tee Connector 3/8 BSP F/F/F	1
11	HV145 - Valve Block	1
11a	HV152 - Solenoid Valve	1
11b	HV140 - Seal Kit, Solenoid Valve	1
12	HJ292 - Hydraulic Hose,Valve Block To Pressur	1
13	HJ291 - Hydraulic Hose,Feed To Pressure Washe	1
14	WP212 - Combined Pump and Motor,Pressure Wash	1
15	HF125 - Restrictor Valve, Jet Wash	1

Pressure Washer - Lance/Hose Reel

Model: **636HS Green Machine**
 From CIN: **1** To CIN: **12**
 Drawing: **636092-8** Revision:

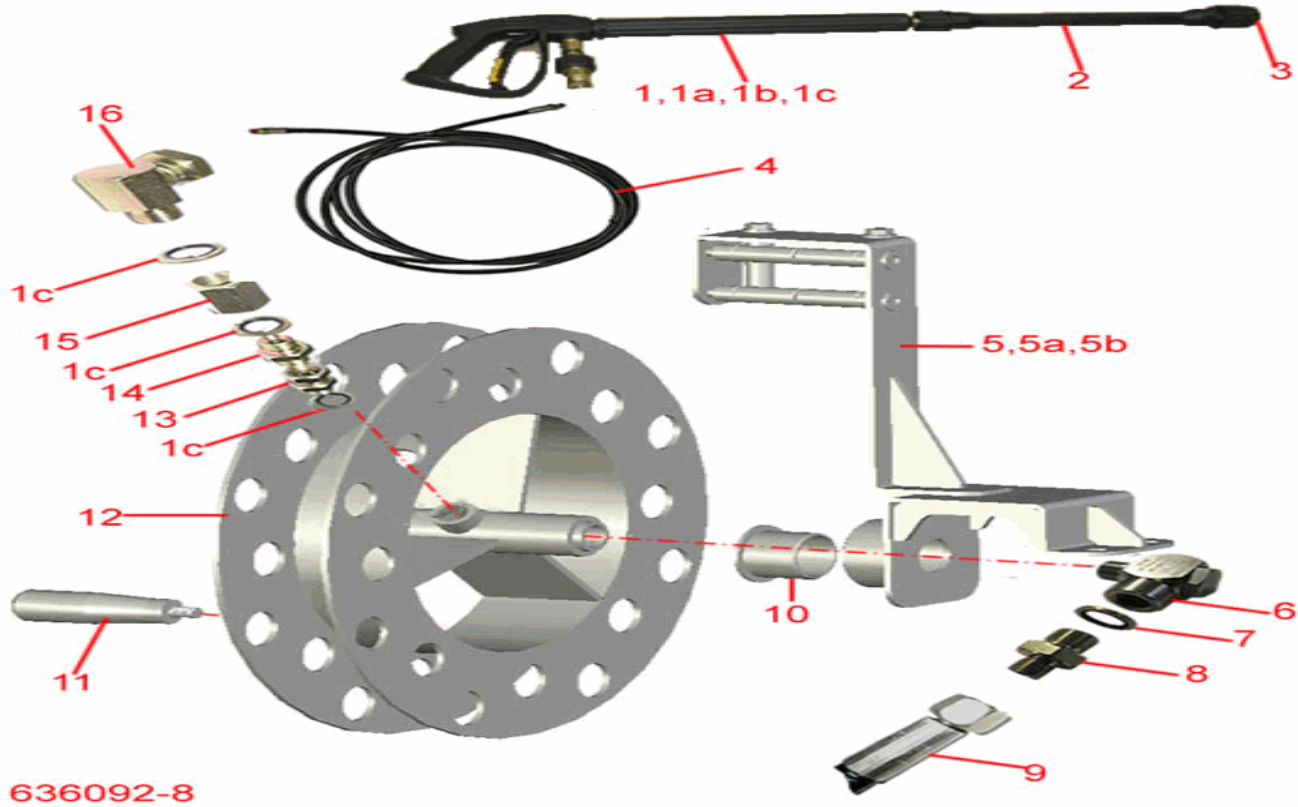

636092-8

1	WA161 - Lance Body (pressure washer)	1	15	HF137 - Adaptor, Fixed - 1/4 BSP F/F	1
1a	WA180 - Swivel Connector - Pressure Washer	1	16	HF113 - Coupling, 90 1/4 Female to Male Swive	1
1b	WA179 - Adaptor, Pressure Washer	1			
1c	HF044 - Hydraulic Bonded Seal - 1/4 BSP (12mm)	4			
2	WA175 - Lance Extention	1			
3	WA160 - Lance Jet 1/4 - 15 Degrees	1			
4	WA193 - Hose Assembly, Reel to Lance - Pressu	1			
5	CD036 - Bracket,Pressure Washer	1			
5a	GB113 - Roller,Nylon-10mm long	6			
5b	GB090 - Roller,Nylon-28mm long	6			
6	WA182 - Swivel, 90 deg.	1			
7	HF010 - Hydraulic Bonded Seal - 3/8 BSP (16mm)	1			
8	HF042 - Hydraulic Adaptor Coupling - 3/8 Male	1			
9	HJ235 - Hose Assy. Motor Blk BP Tee to Cylin	1			
10	GB092 - Bush, Hopper Pivot	1			
11	GG281 - Handle for Reel	1			
12	WA184 - Hose Reel, Pressure Washer	1			
13	HF138 - Adaptor, M/F Swivel - 1/4 BSP	1			
14	HF046 - Hydraulic Stud Coupling - 1/4 Male to	1			

Pressure Washer - Pressure Washer Manifold

Model: 636HS Green Machine
From CIN: 1 To CIN: 12
Drawing: 636096-8 Revision:

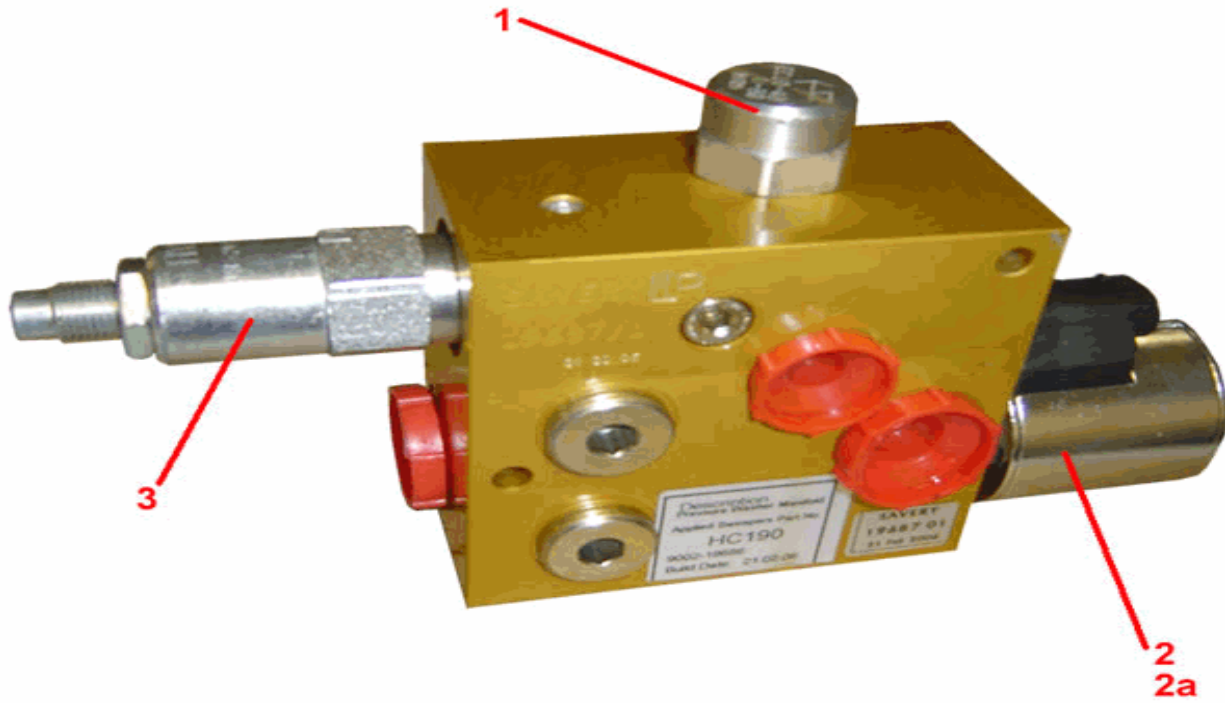

636096-8

1	HV167 - Valve, Pressure Compensator - 80 SPRG	1
1a	HV169 - Seal Kit, Pressure Compensator Valve	1
2	HV095 - Solenoid Valve	1
2a	HV123 - Coil, EY type for SV10 & SV58	1
3	HV204 - HV204 - Relief Valve	1
3a	HV045 - Seal Kit	1

Pressure Washer - Water System

Model: **636HS Green Machine**
 From CIN: **1** To CIN: **12**
 Drawing: **636094-8** Revision:

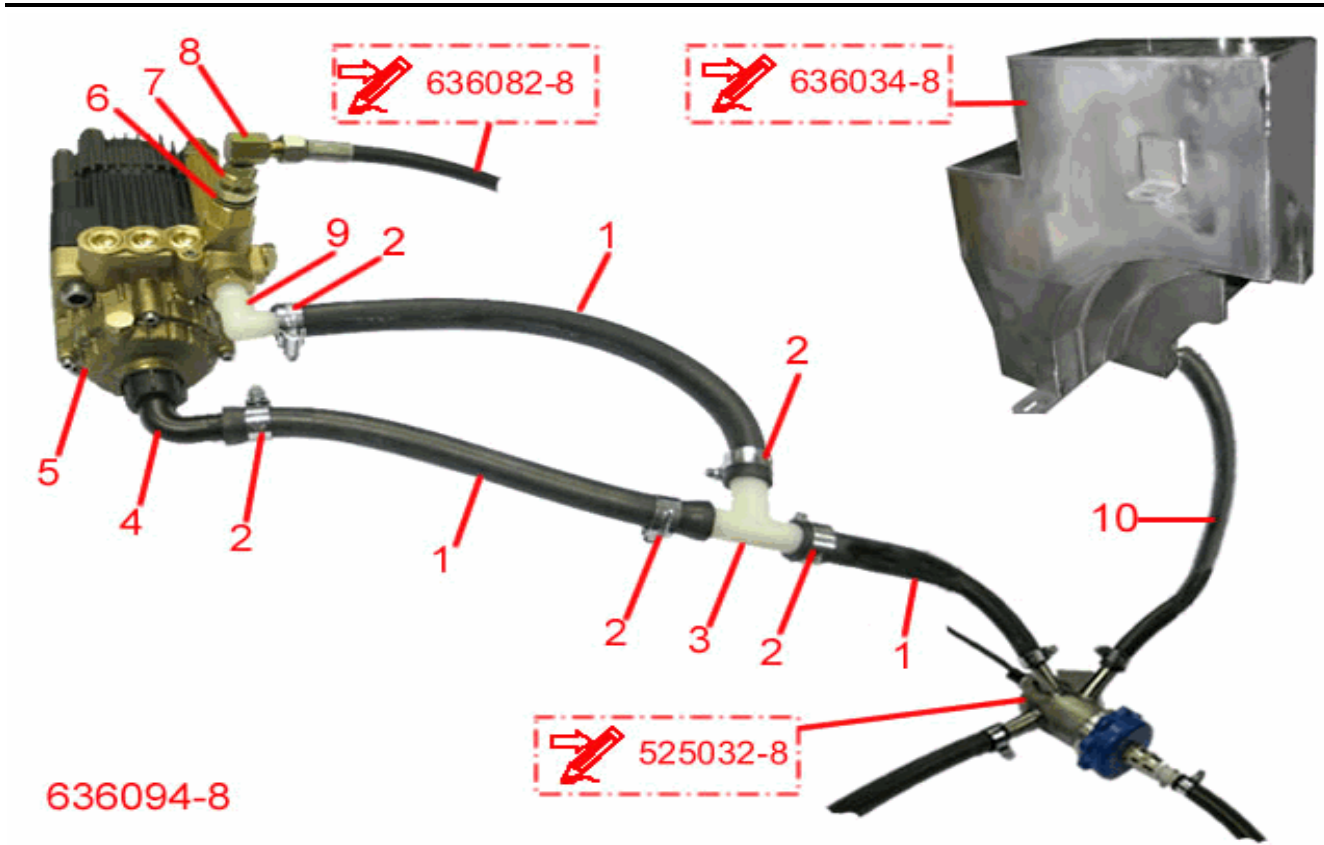

1	WA181 - Hose, Manifold to Pressure Washer	1
2	GG077 - Hose Clamp (14mm to 22mm)	5
3	WP186 - T-Piece,plastic,3/4"	1
4	WP244 - Hose connector,90 Degree	1
5	WP212 - Combined Pump and Motor,Pressure Wash	1
6	HF010 - Hydraulic Bonded Seal - 3/8 BSP (16mm)	1
7	HF042 - Hydraulic Adaptor Coupling - 3/8 Male	1
8	HF113 - Coupling, 90 1/4 Female to Male Swive	1
9	WP240 - Hose connector,90 Degree,3/8" BSP	1
10	WA128 - Water Hose, Small Water Tank to Manif	1

Brush Arm Lift, Left Hand

Model: **636HS Green Machine**
 From CIN: **13** To CIN: **999**
 Drawing: **354834** Revision: **00**

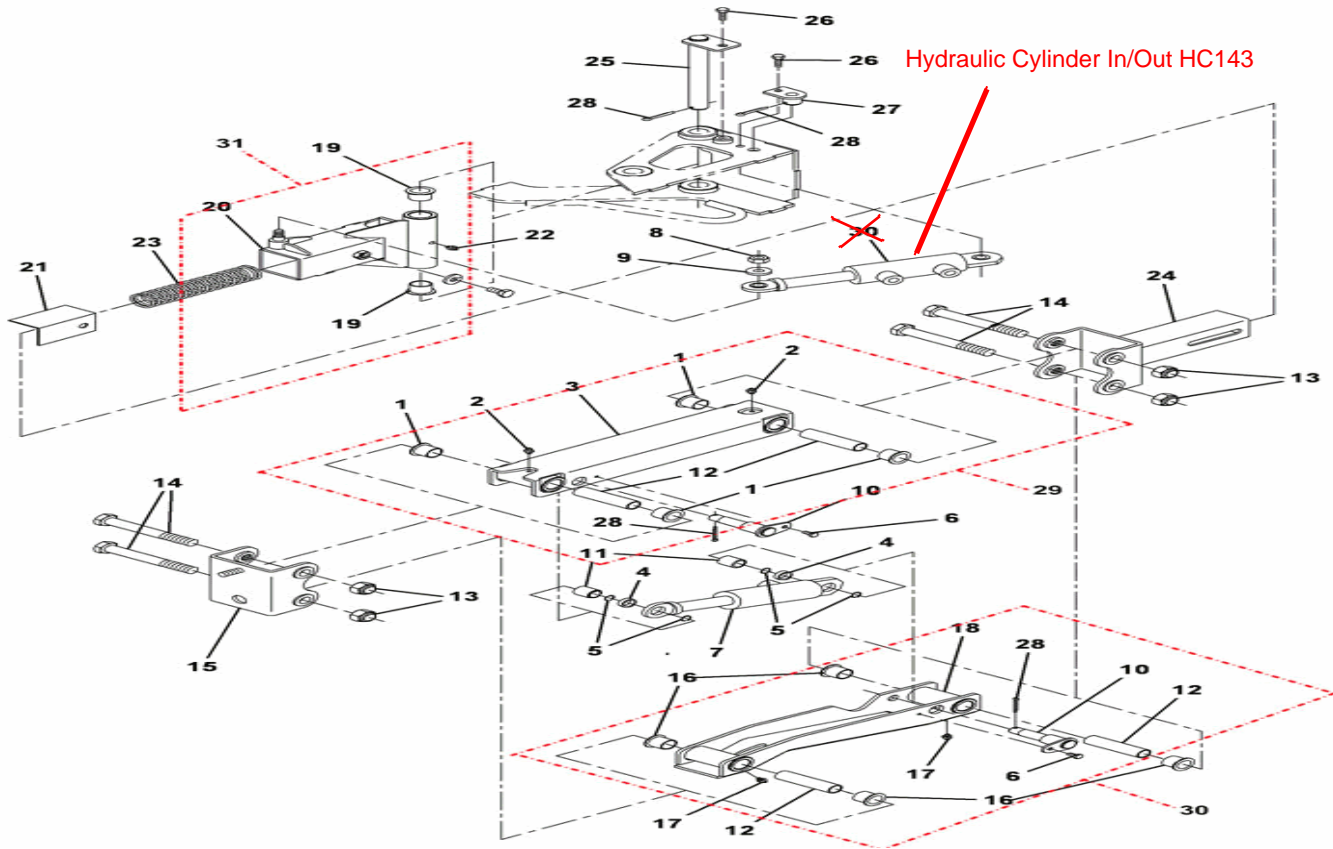

1	GB073 - DU Flanged Bush 20 id x 23 od x 22 l	4	24	NF282 - Extend Brush Arm (for use with larger	1
2	GG039 - Grease nipple	2	25	NF148 - Brush Arm Pivot Pin	1
3	NF156 - Arm Upper, Cylinder Pivot Left Hand -	1	27	NF205 - Anchor Pin - Brush In/Out	1
4	GG247 - Spherical Ball Joint	2	29	NF192 - Brush Upper Arm LH c/w Bushes	1
5	GG248 - Internal Snap Ring 26 mm x 1.2 mm	4	30	NF194 - Lower Brush Arm LH c/w Bushes	1
7	HC160 - Hydraulic Cylinder - Brush Up/Down	1	31	NF137 - Brush Shock Arm Outer Tube LH	1
10	NF164 - Cylinder Pivot Pin Weldment	2			
11	NF198 - Spacer, Cylinder Pivot Pin	2			
12	NF209 - Inner Pivot Tube	4			
14	GT285 - Bolt - M16 x 120	4			
15	NF168 - Front Pivot Mounting Bracket	1			
16	GB073 - DU Flanged Bush 20 id x 23 od x 22 l	4			
17	GG039 - Grease nipple	2			
18	NF163 - Arm, Lower, Cylinder Pivot Left Hand	1			
19	GB073 - DU Flanged Bush 20 id x 23 od x 22 l	2			
20	NF138 - Brush Arm Outer Tube Weldment - Left	1			
21	NF199 - Wear Strip, Brush Arm	2			
22	GG023 - Grease Nipple 45 degree - 6mm	1			
23	NF147 - Brush Shock Spring	2			

Brush Arm Lift, Right Hand

Model: 636HS Green Machine
 From CIN: 13 To CIN: 999
 Drawing: 354833 Revision: 00

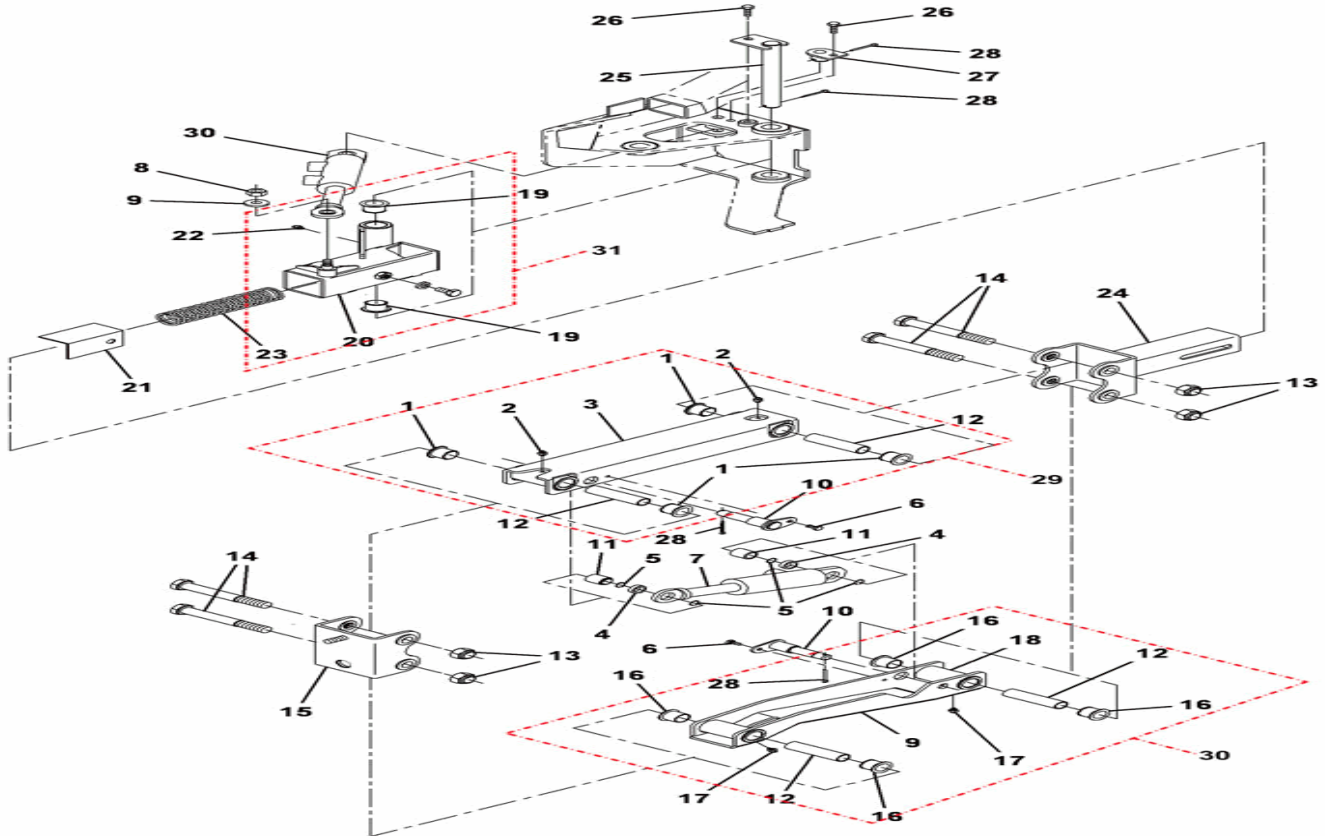

1	GB073 - DU Flanged Bush 20 id x 23 od x 22 l	4	24	NF282 - Extend Brush Arm (for use with larger	1
2	GG039 - Grease nipple	2	25	NF148 - Brush Arm Pivot Pin	1
3	NF151 - Arm, Upper, Cylinder Pivot RH - Weldm	1	27	NF205 - Anchor Pin - Brush In/Out	1
4	GG247 - Spherical Ball Joint	2	29	NF191 - Brush Upper Arm RH c/w Bushes	1
5	GG248 - Internal Snap Ring 26 mm x 1.2 mm	4	30	NF193 - Lower Brush Arm RH c/w Bushes	1
7	HC160 - Hydraulic Cylinder - Brush Up/Down	1	31	NF128 - Brush Shock Arm Outer Tube RH	1
10	NF164 - Cylinder Pivot Pin Weldment	2			
11	NF198 - Spacer, Cylinder Pivot Pin	2			
12	NF209 - Inner Pivot Tube	4			
14	GT285 - Bolt - M16 x 120	4			
15	NF168 - Front Pivot Mounting Bracket	1			
16	GB073 - DU Flanged Bush 20 id x 23 od x 22 l	4			
17	GG039 - Grease nipple	2			
18	NF158 - Arm, Lower, Cylinder Pivot RH - Weldm	1			
19	GB073 - DU Flanged Bush 20 id x 23 od x 22 l	2			
20	NF129 - Brush Arm Outer Tube Weldment	1			
21	NF199 - Wear Strip, Brush Arm	2			
22	GG023 - Grease Nipple 45 degree - 6mm	1			
23	NF147 - Brush Shock Spring	1			

Brush Arm Motor - Left Hand

Model: **636HS Green Machine**
 From CIN: **13** To CIN: **999**
 Drawing: **354832** Revision: **00**

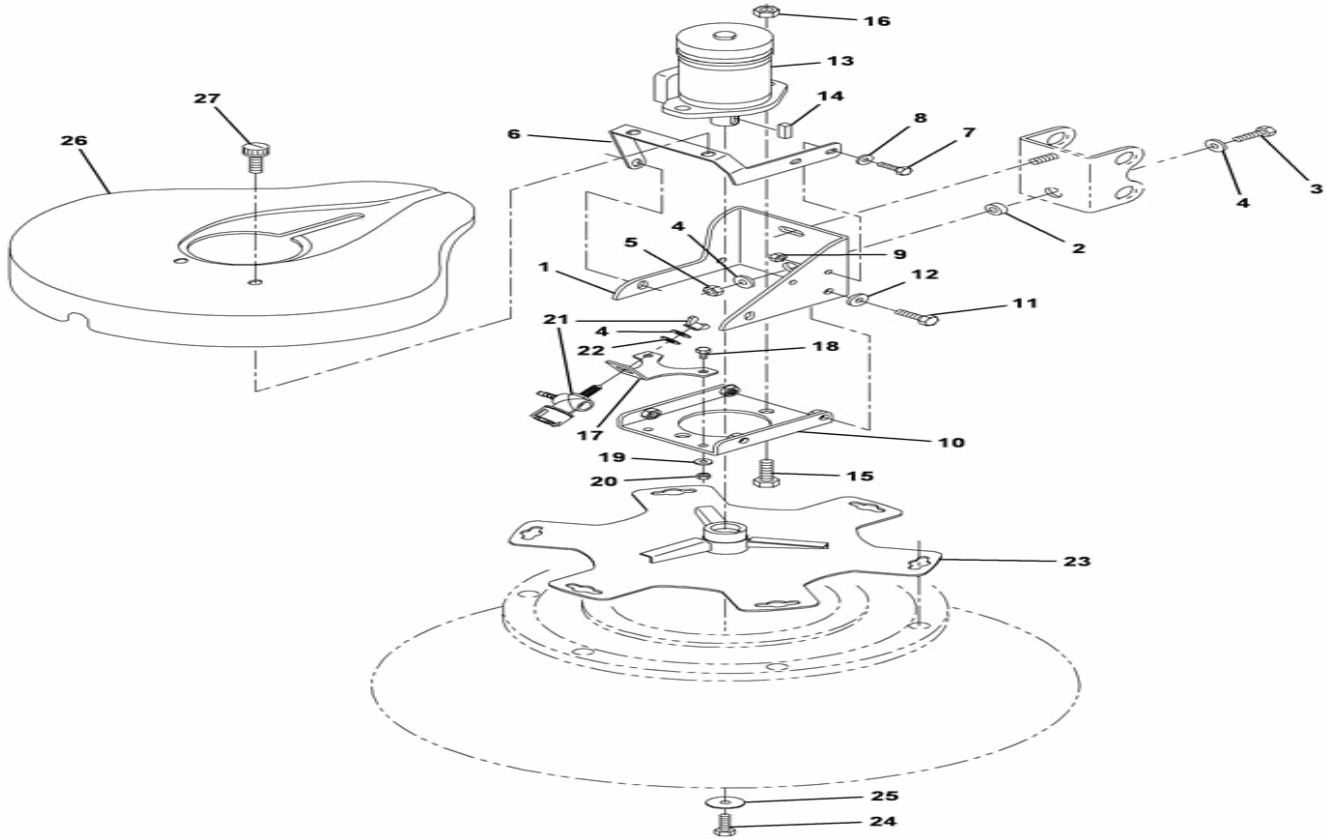

1	NF175 - Motor Swivel Plate -Left Side	1
2	GB036 - Spacer, Black Nylon	1
6	NF177 - Brush Cover Bracket - Left Side	1
10	NF178 - Motor Mounting Plate	1
13	HM029 - Hydraulic Drive Motor, T Type 60cc	1
14	HM037 - Key for Brush Motor	1
17	NF210 - Mounting Plate, Water Hose	1
21	WP165 - Spray Nozzle Holder Assy (Brushes)	1
23	NF184 - Brush Drive Plate Weldment	1
26	CP193_C - Brush Cover	1
27	GG146 - Knurled panel screw	2

Brush Arm Motor - Right Hand

Model: 636HS Green Machine
 From CIN: 13 To CIN: 999
 Drawing: 354831 Revision: 00

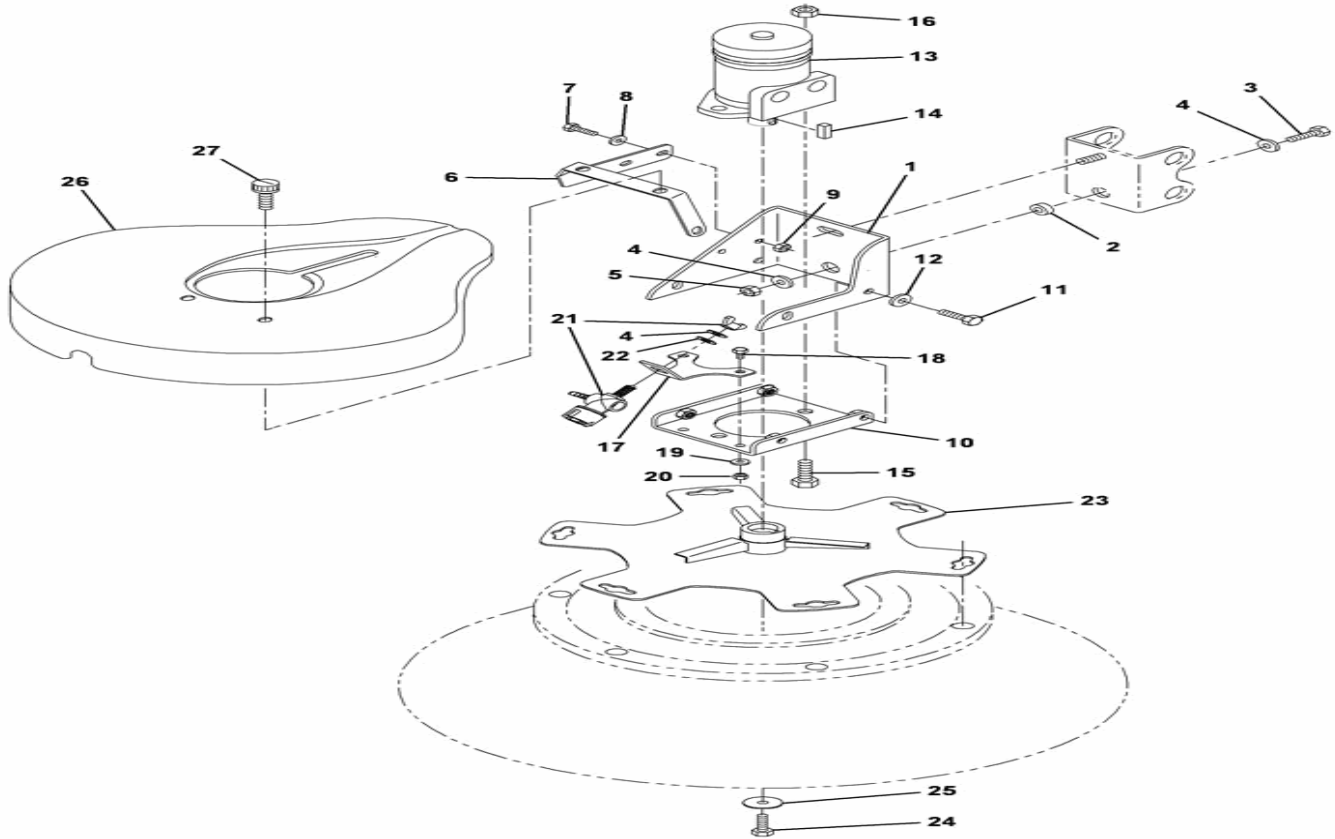

1	NF171 - Motor Swivel Plate - Right Side	1
2	GB036 - Spacer, Black Nylon	1
6	NF173 - Brush Cover Bracket - Right Side	1
10	NF178 - Motor Mounting Plate	1
13	HM029 - Hydraulic Drive Motor, T Type 60cc	1
14	HM037 - Key for Brush Motor	1
17	NF210 - Mounting Plate, Water Hose	1
21	WP165 - Spray Nozzle Holder Assy (Brushes)	1
23	NF184 - Brush Drive Plate Weldment	1
26	CP193_C - Brush Cover	1
27	GG146 - Knurled panel screw	2

Brush Replacement

Model: **636HS Green Machine**
From CIN: **13** To CIN: **999**
Drawing: **354855** Revision: **00**

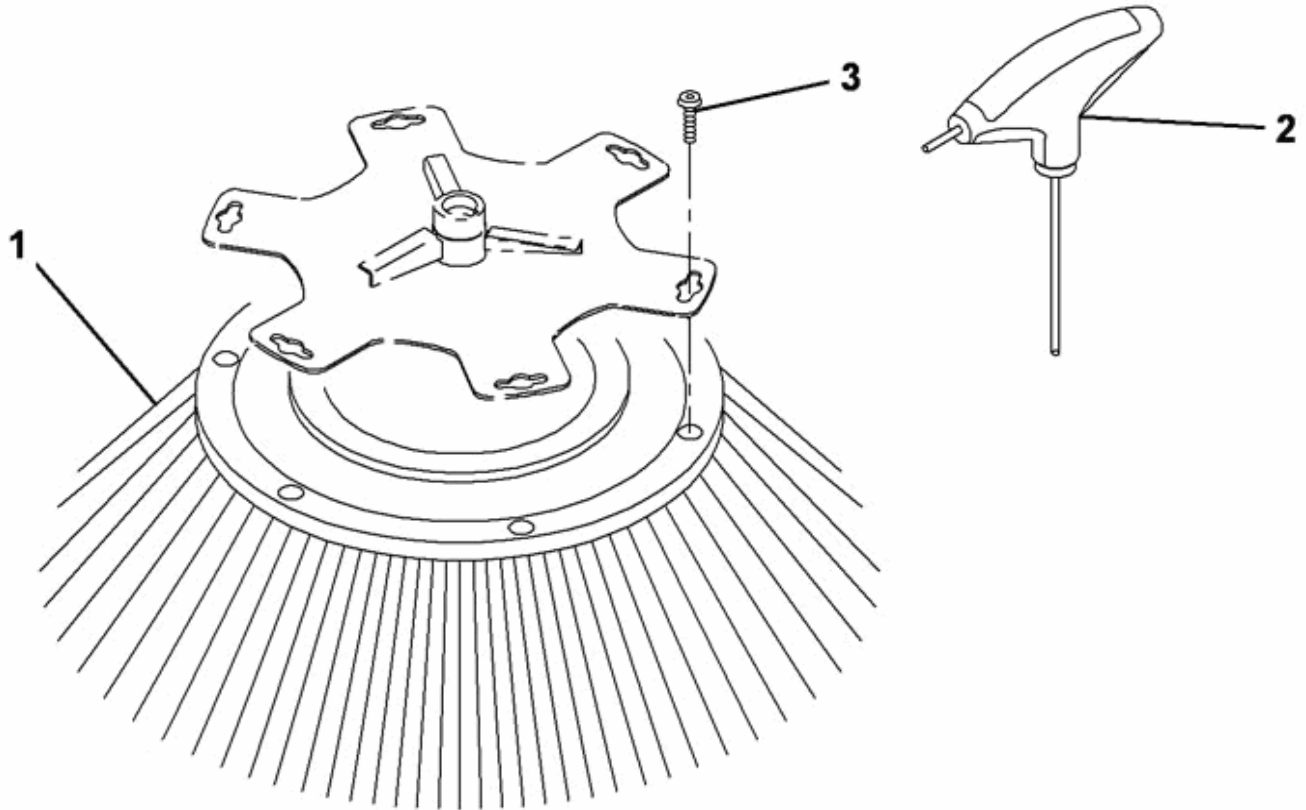

1a	NB064 - Brush : Two Row (Larger Dia. Brush)	2
1a	NB064 - Brush - Two Row (Larger Dia. Brush),	2
1b	NB065 - Brush - Three Row (Larger Dia. Brush)	2
2	KM274 - Tee Allen Key	1
3	GT347 - Screw - Button Head M8 x 80 ST.ST A4	2

Front Brushes & Brush Arms

Model: **636HS Green Machine**
 From CIN: **5** To CIN: **12**
 Drawing: **636106-1** Revision: **a**

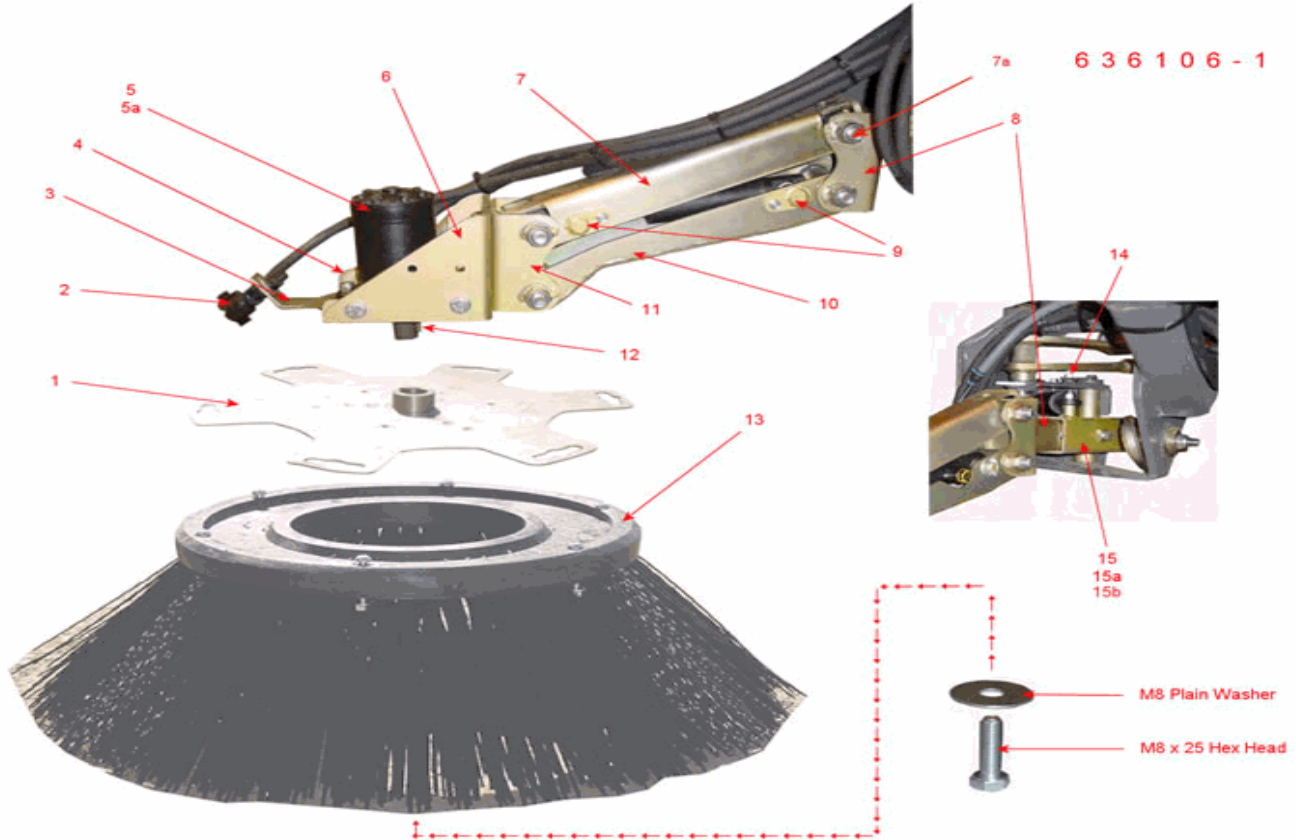

1	NF184 - Brush Drive Plate Weldment	2	6a	NF175 - Motor Swivel Plate -Left Side	1
1	NF184 - Brush Drive Plate Weldment	2	6b	NF173 - Brush Cover Bracket - Right Side	1
2	WP165 - Spray Nozzle Holder Assy (Brushes)	2	6b	NF177 - Brush Cover Bracket - Left Side	1
2	WP165 - Spray Nozzle Holder Assy (Brushes)	2	6c	NF177 - Brush Cover Bracket - Left Side	1
2a	WP160 - Jet Spray	2	6c	NF173 - Brush Cover Bracket - Right Side	1
2a	WP160 - Jet Spray	2	7	NF191 - Brush Upper Arm RH c/w Bushes	1
2b	WP020 - Filter with anti-drip valve	2	7	NF191 - Brush Upper Arm RH c/w Bushes	1
2b	WP020 - Filter with anti-drip valve	2	7a	GB073 - DU Flanged Bush 20 id x 23 od x 22 l	4
3	NF210 - Mounting Plate, Water Hose	2	7a	NF192 - Brush Upper Arm LH c/w Bushes	1
3	NF210 - Mounting Plate, Water Hose	2	7b	GB073 - DU Flanged Bush 20 id x 23 od x 22 l	4
4	NF178 - Motor Mounting Plate	4	7b	NF192 - Brush Upper Arm LH c/w Bushes	1
4	NF178 - Motor Mounting Plate	4	7c	NF209 - Inner Pivot Tube	4
5	HM029 - Hydraulic Drive Motor, T Type 60cc	2	7c	NF209 - Inner Pivot Tube	4
5	HM029 - Hydraulic Drive Motor, T Type 60cc	2	7d	GT285 - Bolt - M16 x 120	4
5a	HM021 - Seal Kit, Hyd. Motor	2	7d	GT285 - Bolt - M16 x 120	4
5a	HM021 - Seal Kit, Hyd. Motor	2	8	NF282 - Extend Brush Arm (for use with larger	2
6	NF171 - Motor Swivel Plate - Right Side	1	8	NF141 - Brush Shock Arm Inner Tube	2
6	NF171 - Motor Swivel Plate - Right Side	1	9	NF164 - Cylinder Pivot Pin Weldment	4
6a	NF175 - Motor Swivel Plate -Left Side	1	9	NF164 - Cylinder Pivot Pin Weldment	4

Front Brushes & Brush Arms

Model: **636HS Green Machine**
 From CIN: **1** To CIN: **4**
 Drawing: **636105-1** Revision:

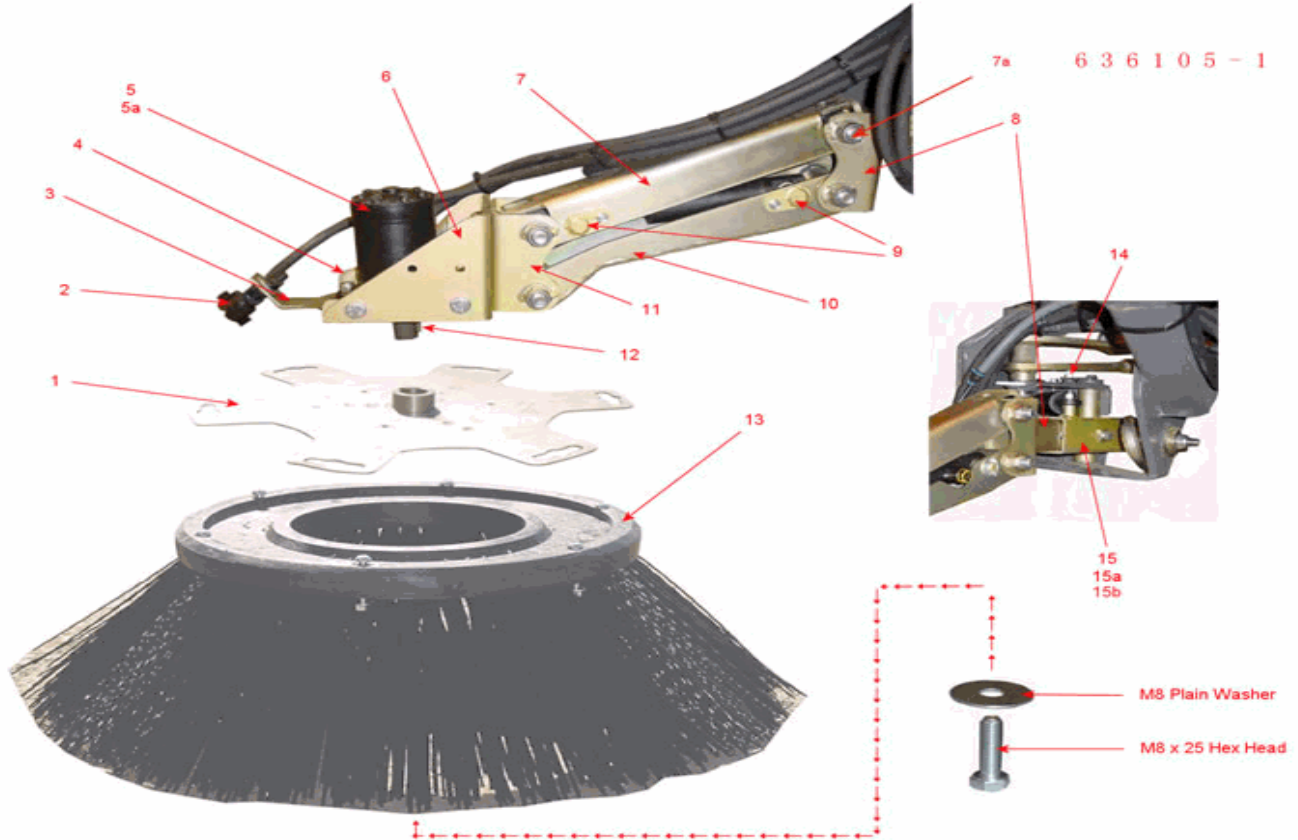

10	NF193 - Lower Brush Arm RH c/w Bushes	1	15a	NF137 - Brush Shock Arm Outer Tube LH	1
10	NF193 - Lower Brush Arm RH c/w Bushes	1	15a	NF137 - Brush Shock Arm Outer Tube LH	1
10a	NF194 - Lower Brush Arm LH c/w Bushes	1	15b	NF147 - Brush Shock Spring	2
10a	NF194 - Lower Brush Arm LH c/w Bushes	1	15b	NF147 - Brush Shock Spring	2
10b	GB073 - DU Flanged Bush 20 id x 23 od x 22 l	4	15c	NF199 - Wear Strip, Brush Arm	4
10b	GB073 - DU Flanged Bush 20 id x 23 od x 22 l	4	15c	NF199 - Wear Strip, Brush Arm	4
10c	NF209 - Inner Pivot Tube	4			
10c	NF209 - Inner Pivot Tube	4			
10d	GT285 - Bolt - M16 x 120	4			
10d	GT285 - Bolt - M16 x 120	4			
11	NF168 - Front Pivot Mounting Bracket	2			
11	NF168 - Front Pivot Mounting Bracket	2			
12	HM037 - Key for Brush Motor	2			
12	HM037 - Key for Brush Motor	2			
13	NB065 - Brush - Three Row (Larger Dia. Brush)	2			
13	NB058 - Brush - Poly - 500/600 Series	2			
14	NF205 - Anchor Pin - Brush In/Out	2			
14	NF205 - Anchor Pin - Brush In/Out	2			
15	NF128 - Brush Shock Arm Outer Tube RH	1			
15	NF128 - Brush Shock Arm Outer Tube RH	1			

Vacuum System - Drain Access Door

Model: 636HS Green Machine
From CIN: 1 To CIN: 12
Drawing: 636071-8 Revision:

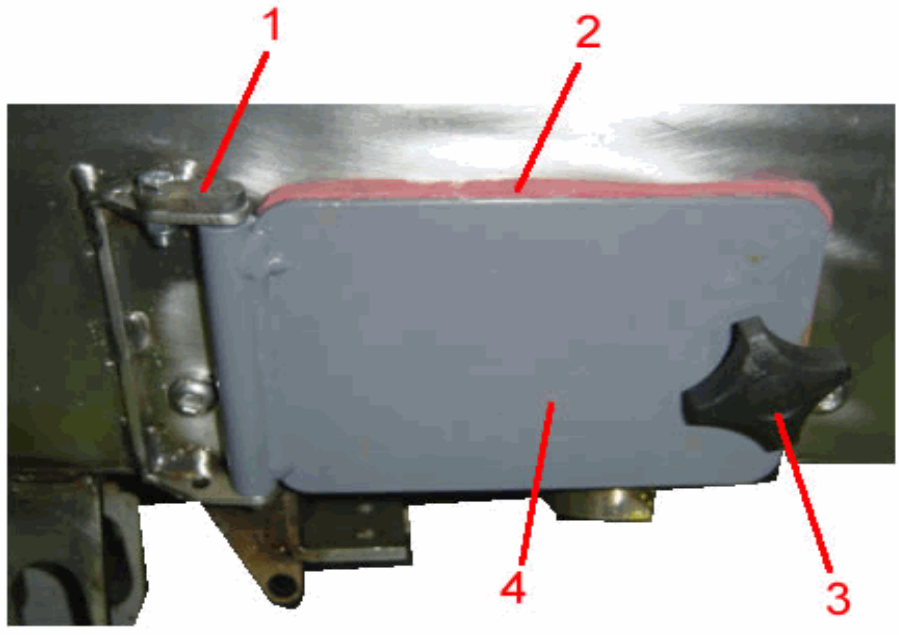

636071-8

1	VH567 - Hinge Pin - Whoosh	1
2	CD168 - Door Seal - Drain Access	1
3	GG289 - Knob-Drain Access Door	1
4	CD165 - Drain Door	1

Vacuum System - Fan Inspection Door

Model: 636HS Green Machine
From CIN: 1 To CIN: 12
Drawing: 636074-8 Revision:

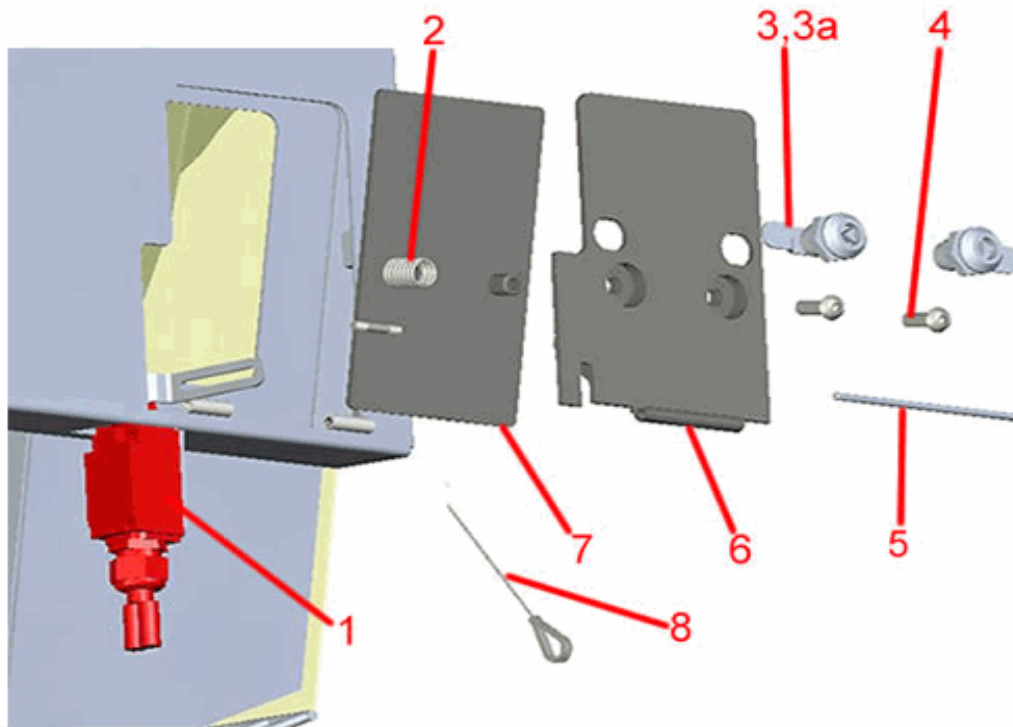

636074-8

1	ES404 - Safety Switch, Fan Door	1
2	GG213 - Compression Spring	2
3	GG286 - Access Door Lock	2
3a	VH650 - Lock Spacer	2
4	GT332 - Screw, M8x25mm Buttonhead St/St	1
5	VH609 - Hinge Pin - Access Door	1
6	VH599 - Outer Plate - Access Door	1
7	VH606 - Inner Access Plate	1
8	VH658 - Wire, Inspection Door Restraining	1

Vacuum System - Front Nozzle

Model: **636HS Green Machine**
 From CIN: **1** To CIN: **12**
 Drawing: **636065-8** Revision:

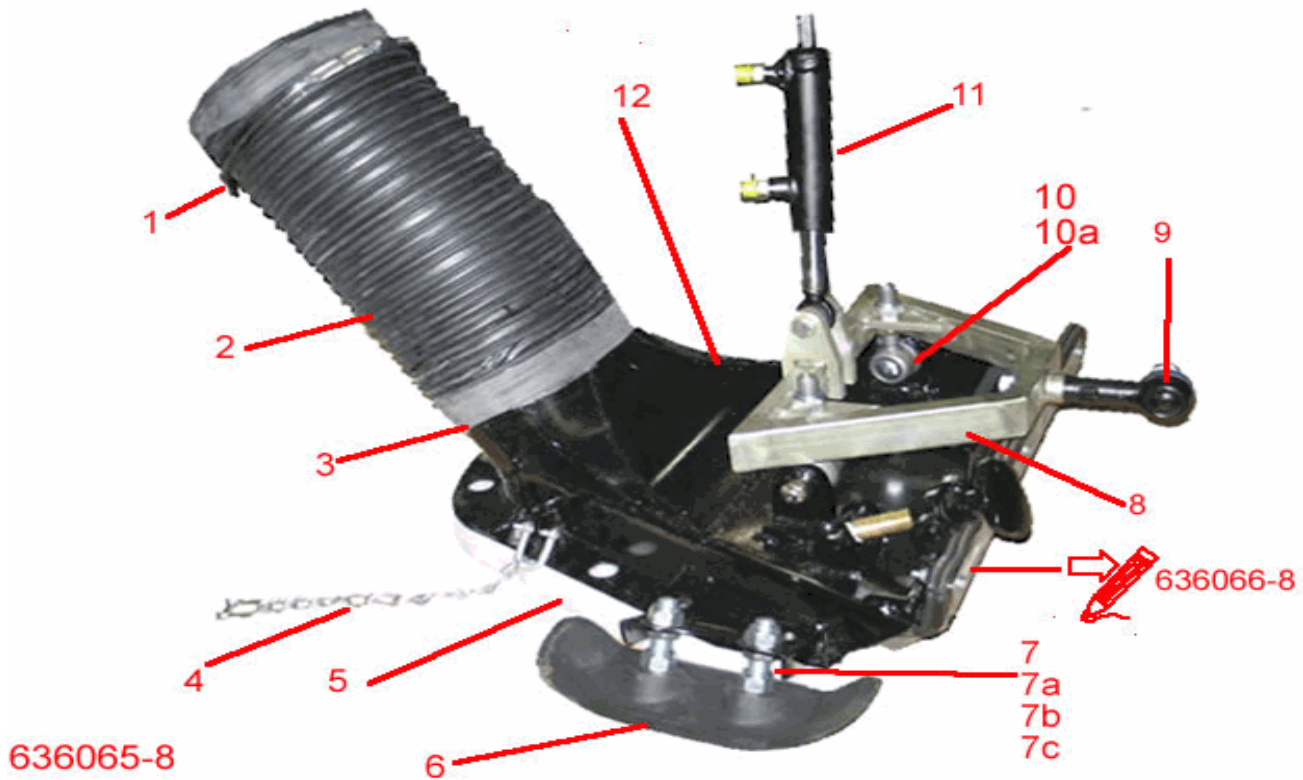

1	GG015 - Hose Clamp (8.5 inch)	1
2	VT188 - Front Nozzle Hose	1
3	GM013 - Rubber band - 8 in. diameter	2
4	NA082 - Chain & Shackles	2
5	NA138 - Horseshoe Wear Pad	1
6	NN112 - Side Skid Shoe	2
7	GT311 - M16 x 100 lg Setscrew	4
7a	GN075 - M16 Thin Nut	4
7b	GW084 - M16 Washer	4
7c	GN068 - M16 Nylon Nut	8
8	NA137 - Nozzle A-Frame Assembly	1
9	GG229 - Ball Joint, Track Rod/Drag Link End	1
10	GG263 - Ball Joint, Track Rod End	2
10a	GW084 - M16 Washer	2
10a	GN064 - Nut Hex Lock Thin - M16 x 1.5P	2
11	HC145 - Hyd. Cylinder, Nozzle Up/Down	1
12	NA118 - Nozzle Body Assy	1

Vacuum System - Hopper Drain Flap

Model: 636HS Green Machine
From CIN: 1 To CIN: 12
Drawing: 636070-8 Revision:

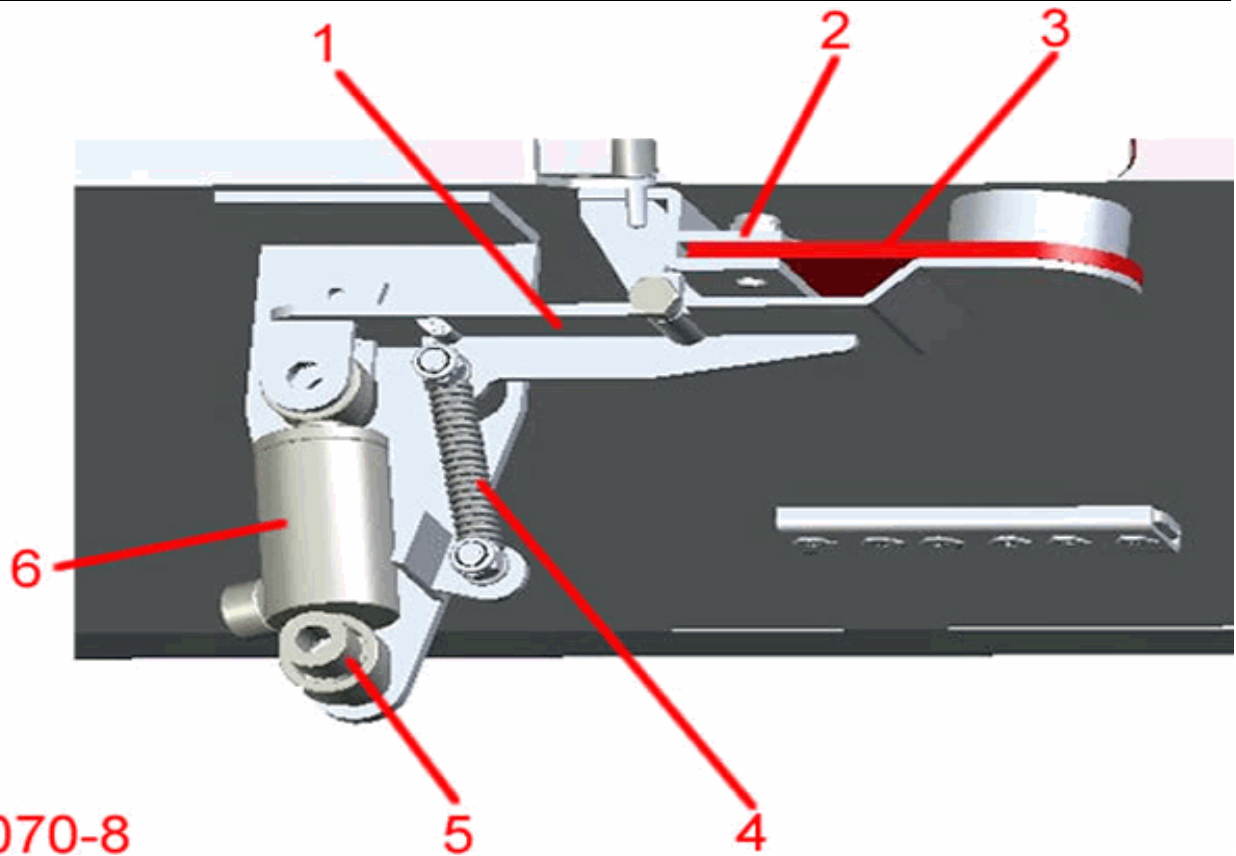

636070-8

1	CD146 - Drain Flap Actuator	1
2	CD155 - Plate,Drain Flap Retaining	1
3	CD154 - Seal,Drain Flap	1
4	GG285 - Spring,Drain Flap	1
5	PP154 - Spacer,Drain Flap Cylinder	2
6	HC128 - Hydraulic Cylinder - pitch lock	1

Vacuum System - Hopper Ducts

Model: 636HS Green Machine
From CIN: 1 To CIN: 12
Drawing: 636069-8 Revision:

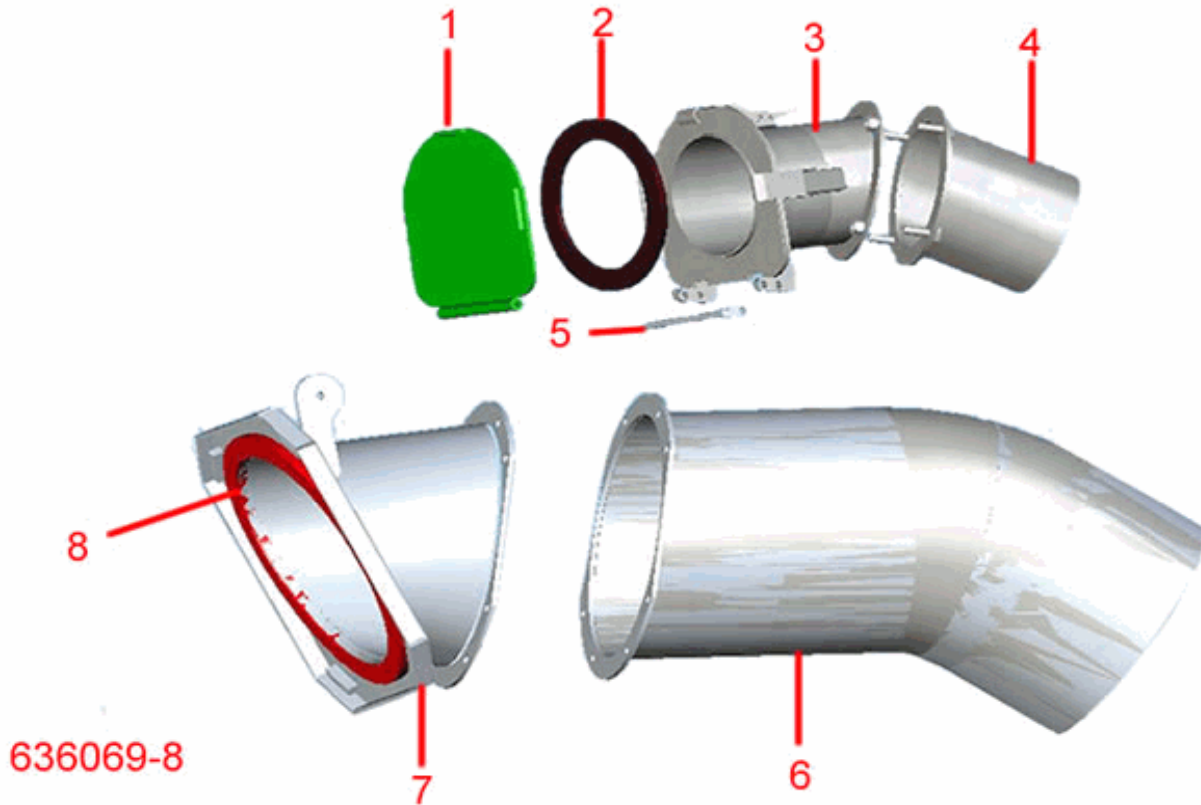

1	VH563 - Blanking Plate Assembly - Whoosh Inle	1
2	VH570 - Seal, Whoosh Inlet	1
3	VH551 - Whoosh Tube, Outer	1
4	VH560 - Whoosh Tube, Inner	1
5	VH567 - Hinge Pin - Whoosh	1
6	VH542 - Inlet Duct Tube (Inner)	1
7	VH526 - Inlet Duct	1
8	VH541 - Seal, Inlet Duct	1

Vacuum System - Hopper Front

Model: 636HS Green Machine
From CIN: 1 To CIN: 12
Drawing: 636068-8 Revision:

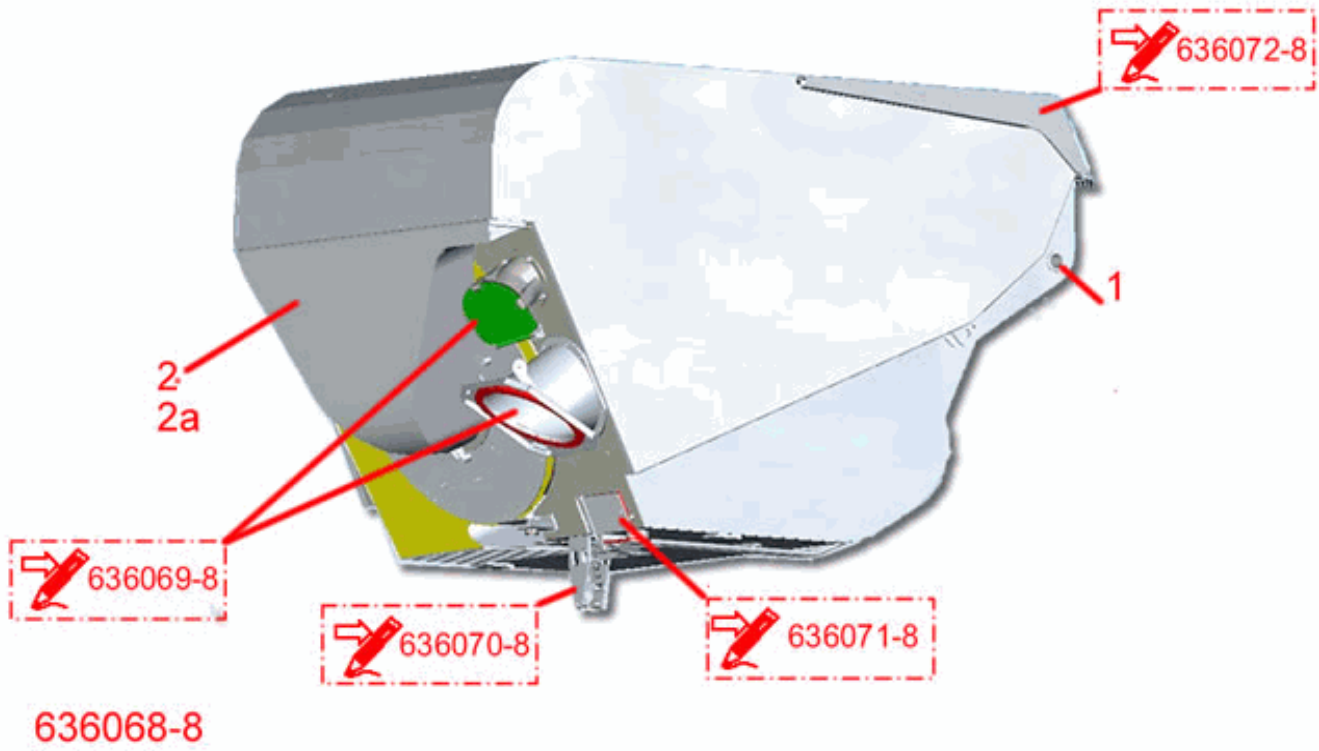

1	GB092 - Bush, Hopper Pivot	4
2	VH626 - Inlet Cover, Front	1
2a	GM475 - Seal, Inlet Cover	1

Vacuum System - Hopper Rear

Model: 636HS Green Machine
From CIN: 1 To CIN: 12
Drawing: 636073-8 Revision:

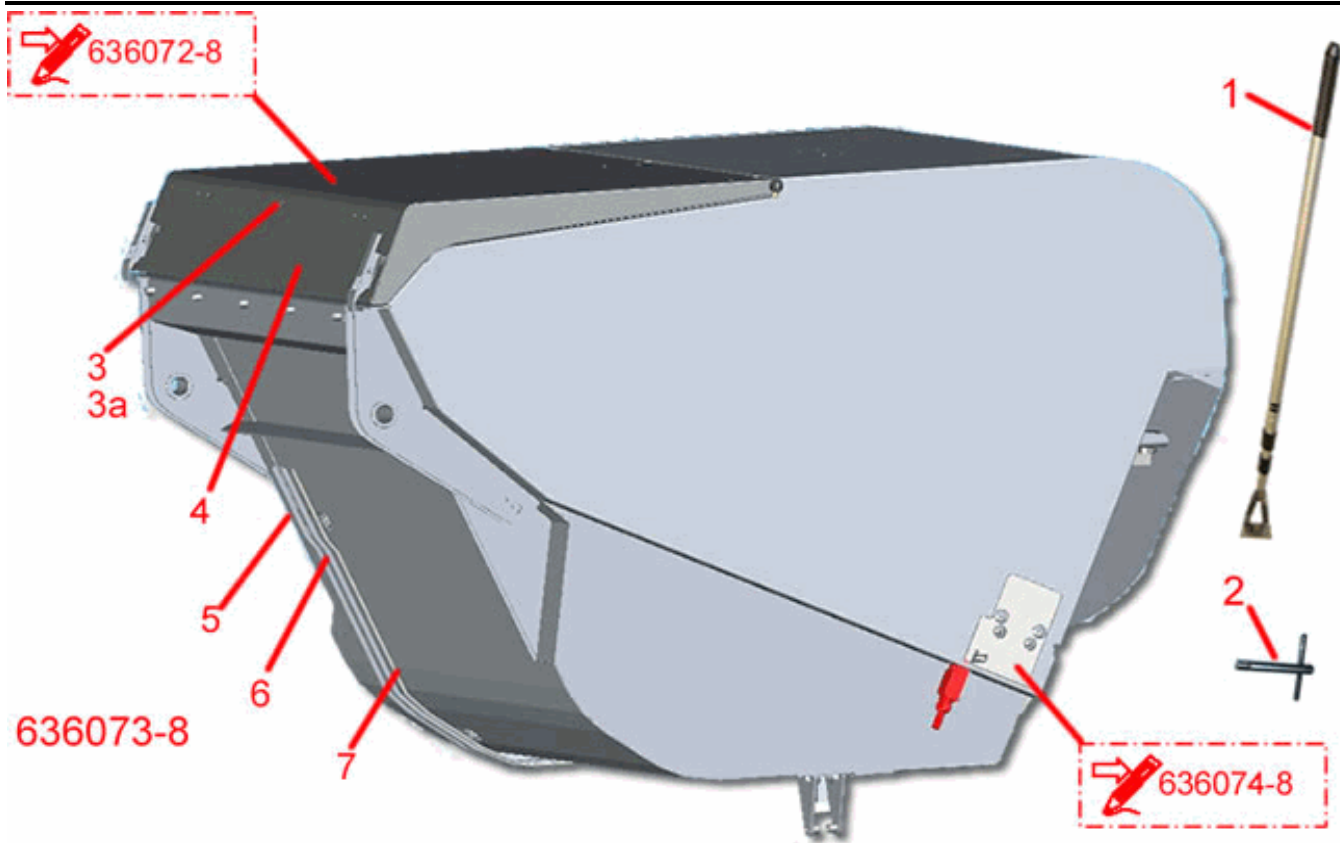

1	CD296 - Hopper Scraper Assembly	1
2	GG287 - Fan Inspection Door Key	1
3	EC021 - Rear View Camera, Low Light	1
3a	EC024 - Camera Cable, Chassis to Camera 2.5mt	1
4	GM395 - Decal, Chevron - Hopper	1
5	HJ304 - Pipe,12mm-Vacuum Fan Feed	1
6	HJ305 - Pipe,12mm-Vacuum Fan Return	1
7	HJ306 - Pipe,6mm-Vacuum Fan Drain	1

Vacuum System - Hopper Rear Door

Model: 636HS Green Machine
From CIN: 1 To CIN: 12
Drawing: 636072-8 Revision:

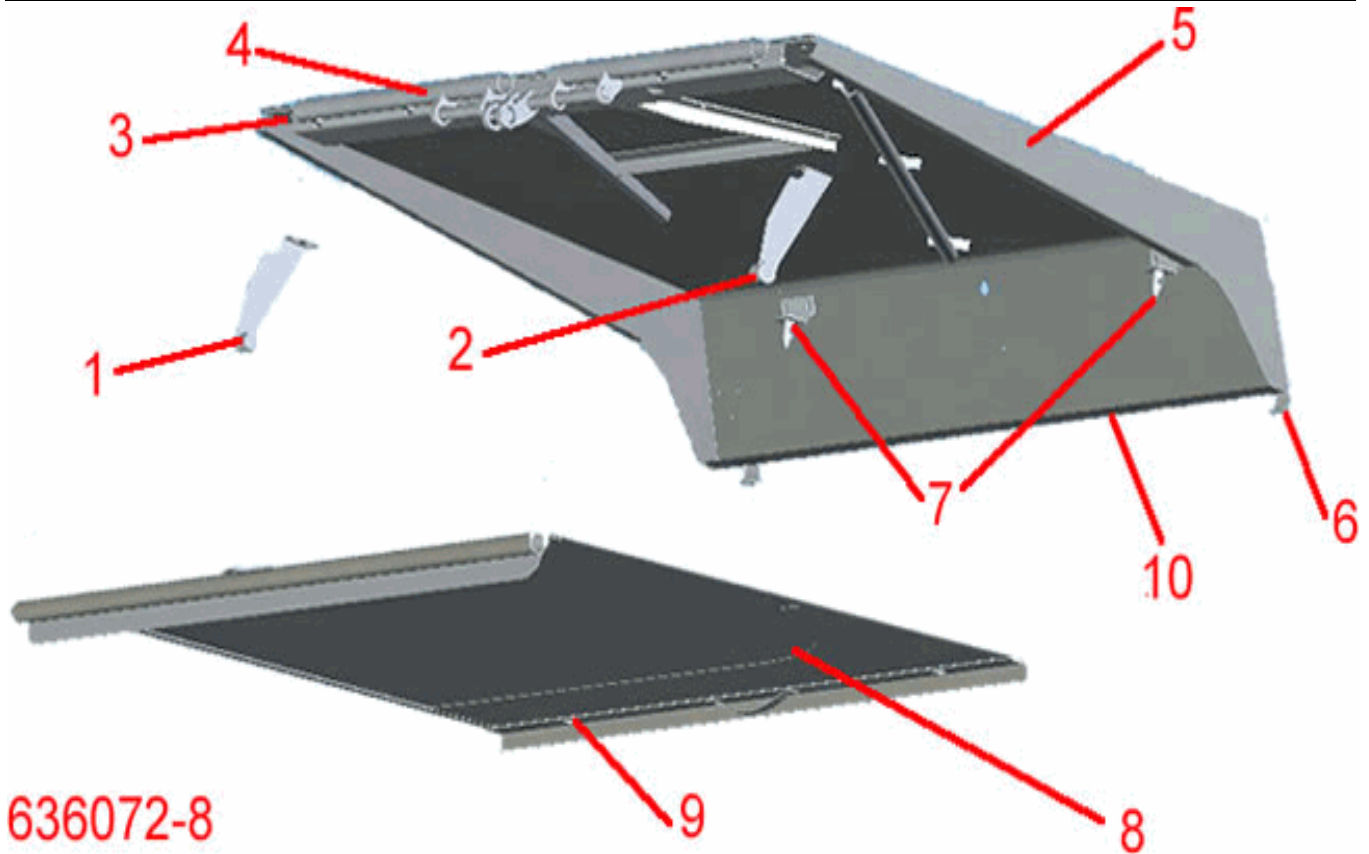

1	VH122 - Hinge Plate RH - Rear Door	1
2	VH125 - Hinge Plate LH - Rear Door	1
3	VH104 - Hinge Tube	1
3a	GB093 - Bush	0
4	VH386 - Door Hinge Weldment	1
5	VH613 - Hopper Door	1
6	GG157 - Adjustable Latch	2
7	VH216 - Mounting Plate - Hopper	2
8	VH540 - Rear Mesh Door	1
9	VH181 - Lynch Pin Assembly - Hopper	2
10	GM391 - Hopper Door Seal	1

Vacuum System - Inlet Duct

Model: 636HS Green Machine
From CIN: 1 To CIN: 12
Drawing: 636067-8 Revision:

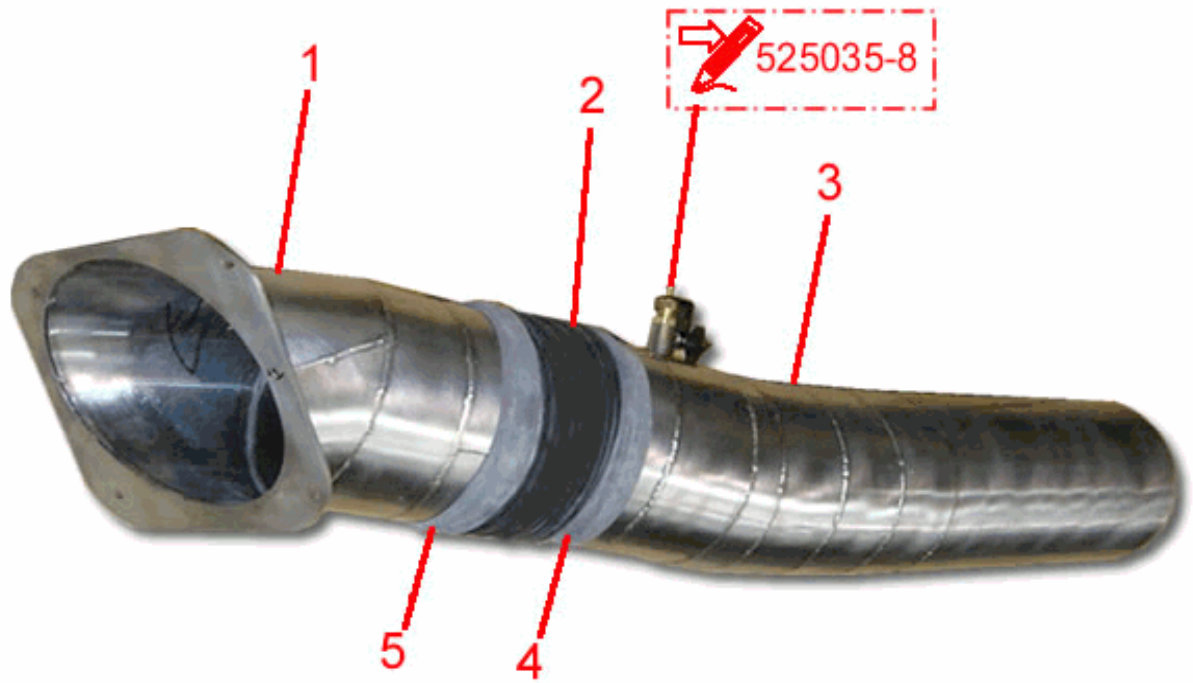

636067-8

1	VH580 - Inlet Duct, Upper	1
2	VT202 - Cuff, Inlet Duct	1
3	VH644 - Inlet Duct, Lower	1
4	GM013 - Rubber band - 8 in. diameter	2
5	GG015 - Hose Clamp (8.5 inch)	2

Vacuum System - Nozzle Flap

Model: 636HS Green Machine
From CIN: 1 To CIN: 12
Drawing: 636066-8 Revision:

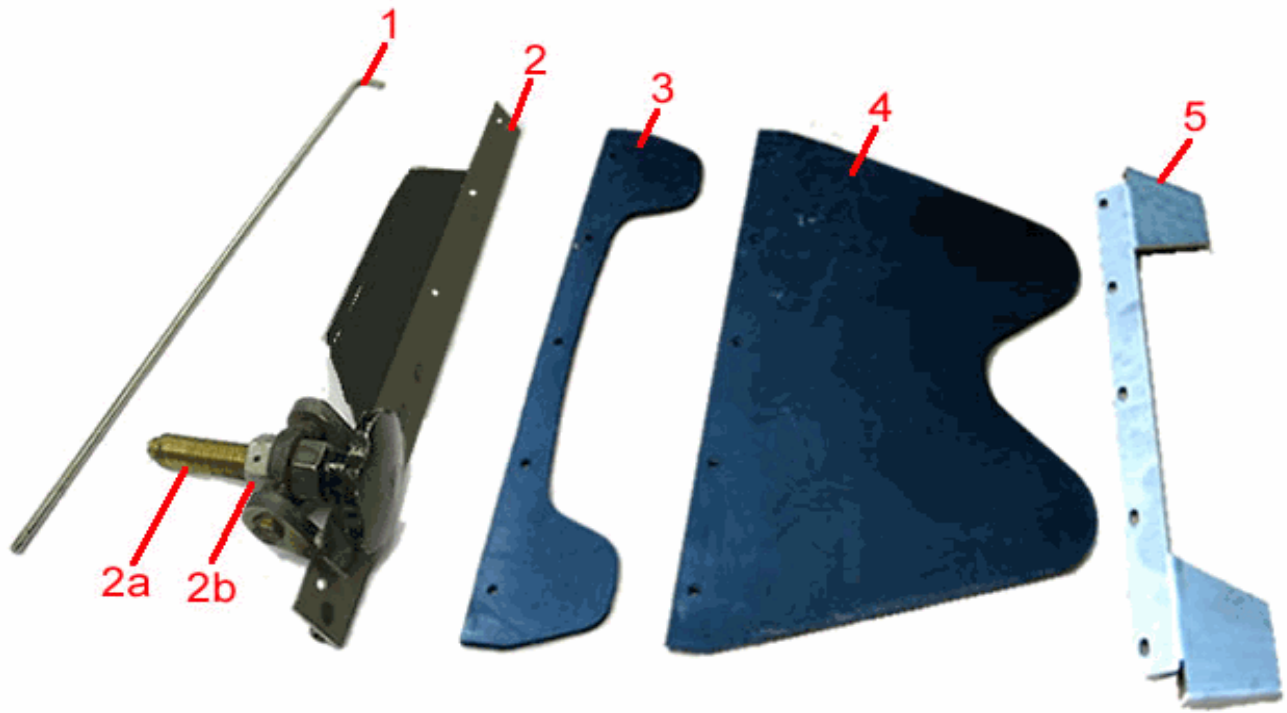

636066-8

1	NA134 - Pin, Nozzle Flap	1
2	NA120 - Flap, Adjustable Nozzle	1
2a	NF045 - Adjuster screw for brush height	1
2b	GN025 - Nut, 3/4" UNF	2
3	NA087 - Backing Strip - Nozzle Flap	1
4	NA117 - Nozzle Flap	1
5	NA135 - Brush Guard	1

Vacuum System-Clean Fan

Model: 636HS Green Machine
From CIN: 1 To CIN: 12
Drawing: 636075-8 Revision:

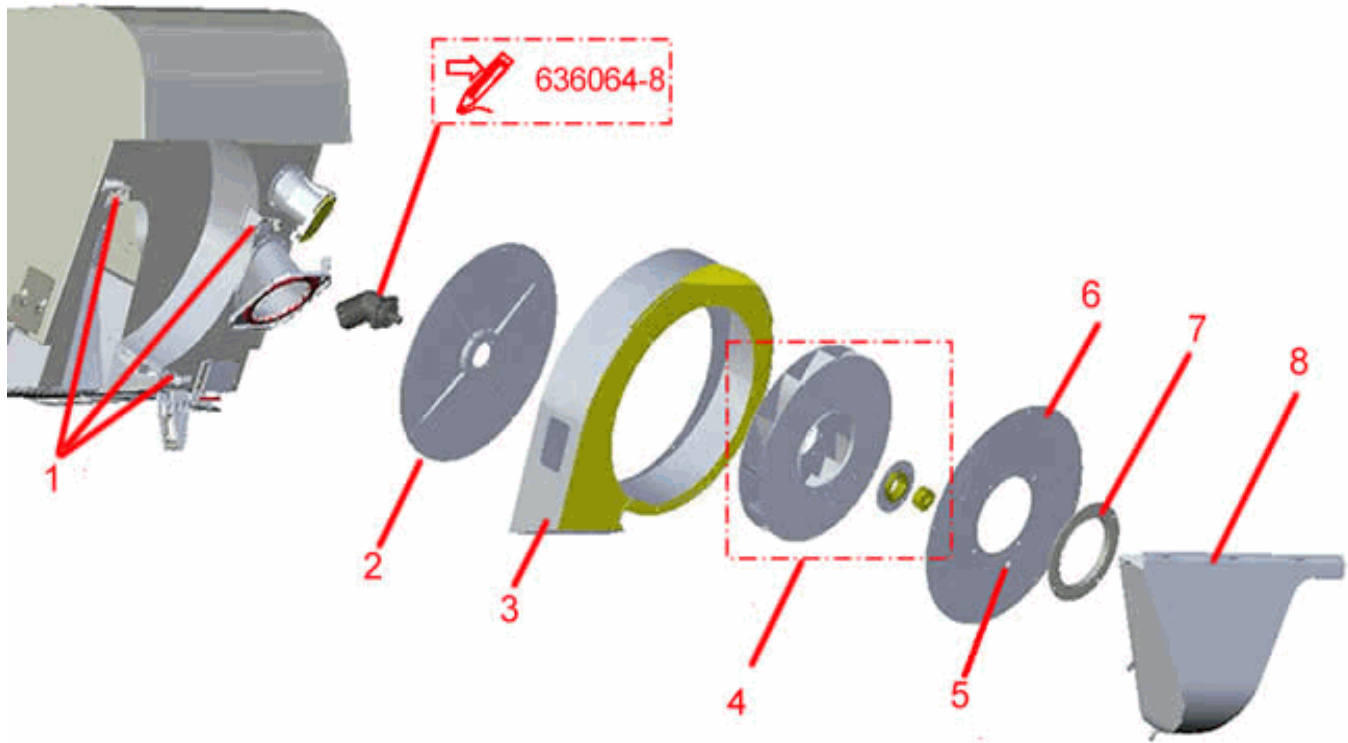

636075-8

1	GG231 - Rubber Anti-Vibration Mount, 2 Piece	3
2	CC362 - Mounting Plate,Fan Motor	1
3	CC356 - Scroll Case,Fan	1
4	VF103 - Clean Fan c/w Mounting Plate and Bush	1
5	ES279 - Vacuum Fan/Eng. Speed Sensor c/w plu	1
6	CC371 - Front Plate,Fan Casing	1
7	CC381 - Inlet Collar,Fan	1
8	VH626 - Inlet Cover, Front	1

Vacuum System-Cyclones

Model: **636HS Green Machine**
 From CIN: **1** To CIN: **12**
 Drawing: **636077-8** Revision:

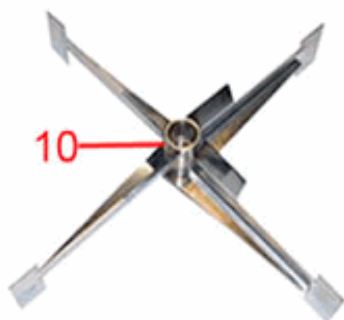
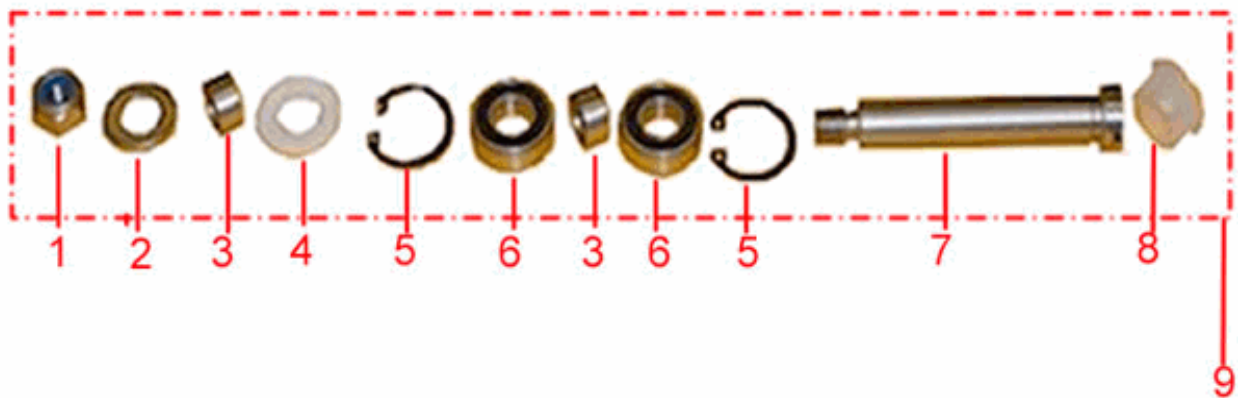

636077-8

1	GN069 - M8 Locknut - Nylon (Stainless Steel)	1
2	GW079 - M10 Washer - Form A (Stainless Steel)	1
3	VH272 - Spinner Spacer (Cyclone)	2
4	GM401 - Felt Washer - 22 O/D x 10.5 I/D	1
5	GG276 - Internal Circlip 22 mm bore	2
6	GB100 - Bearing, Single Row	2
7	VH271 - Spinner Shaft Bearing (Cyclone)	1
8	GM399 - Blanking Plug	1
9	VH373 - Cyclone Spinner Bearing Kit	1
10	VH273 - Cyclone Spinner	1
11	VH274 - Cyclone Assembly Complete	1

Vacuum System-Hopper Linkages

Model: **636HS Green Machine**
 From CIN: **1** To CIN: **12**
 Drawing: **636076-8** Revision:

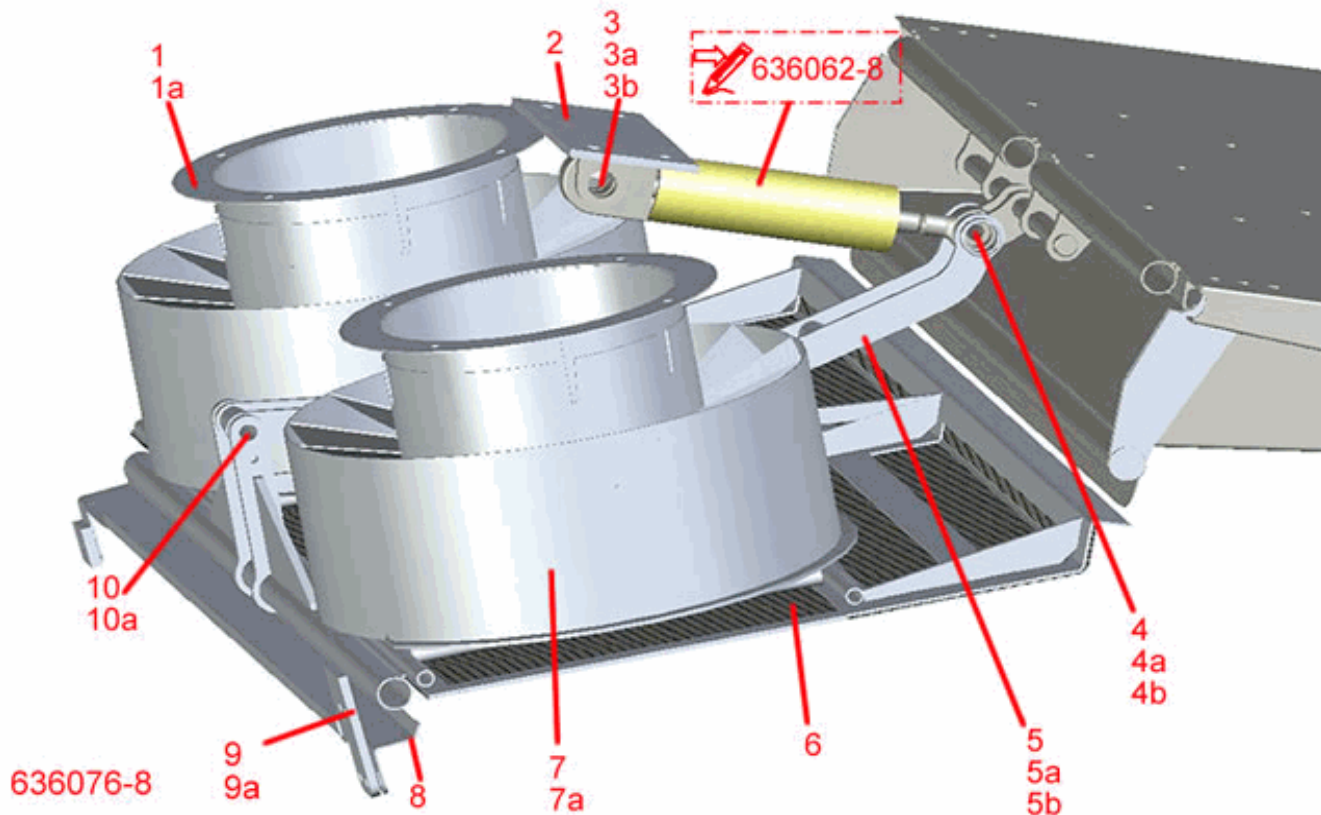

Hopper Body hidden for clarity

1	VH536 - Sleeve,Cyclone	2	10a	GG264 - Split Pin - Stainless Steel (4.0 x 20)	1
1a	GG277 - Clamp, Heavy Duty	2			
2	VH610 - Clevis Plate	1			
3	VH142 - Pin, Door Hydraulic Cylinder	1			
3a	GW077 - M20 Washer - Form A (Stainless Steel)	2			
3b	GG272 - Split Pin - Stainless Steel (4.0 x 30)	2			
4	VH253 - Pin, Hydraulic Cylinder	1			
4a	GW077 - M20 Washer - Form A (Stainless Steel)	1			
4b	GG272 - Split Pin - Stainless Steel (4.0 x 30)	1			
5	VH516 - Pivot Arm-Cyclone Mesh Door	1			
5a	GB031 - Bush, Flanged DU - 12 I/D x 14 O/D x	2			
5b	GB099 - Bush, Flanged DU - 20 I/D x 23 O/D x	2			
6	VH410 - Mesh Door,Cyclones	1			
7	VH259 - Hopper Cyclone Body	2			
8	VH639 - Closing Plate,Cyclones	1			
9	VH453 - Mesh Door Bracket	1			
9a	GB093 - Bush	2			
10	VH251 - Pin, Hydraulic Cylinder	1			

Vacuum Systems - Hopper Safety Switch

Model: 636HS Green Machine
From CIN: 1 To CIN: 12
Drawing: 636103-1 Revision: 1

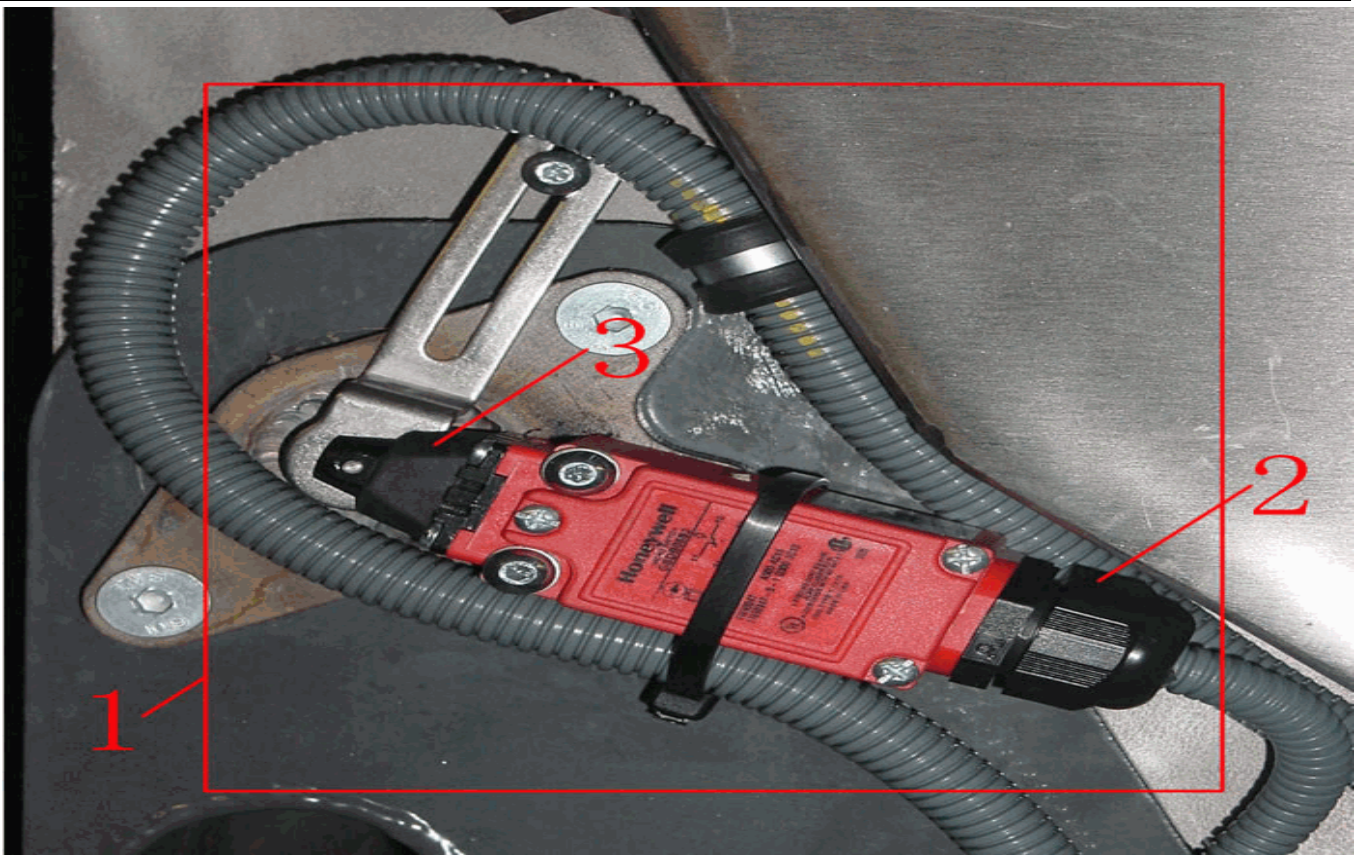

1	ES283 - Safety Limit Switch c/w cable gland	1
2	ET098 - Compression Gland	1
3	GM496 - Safety Switch Seal	1

Water System - Cloudmaker

Model: 636HS Green Machine
From CIN: 1 To CIN: 12
Drawing: 636036-8 Revision:

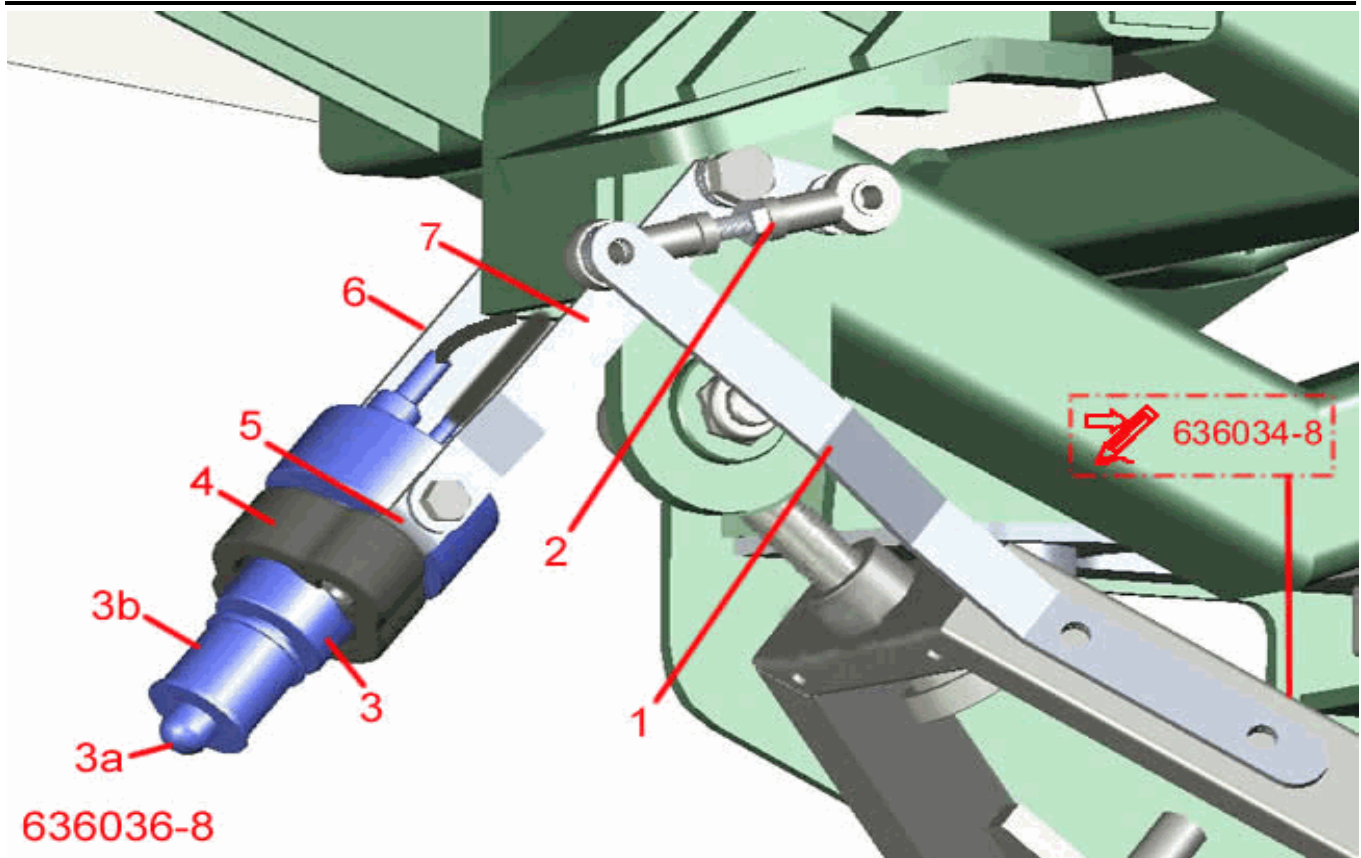

1	CD244 - CD244 - Link Arm, Nozzle To Cloudmaker	1
2	CD232 - CD232 - Connector Rod, Cloudmaker	1
3	WA269 - Atomising Spray Assembly with plug	1
3a	WA274 - WA274 - Nut, Rotary atomiser	1
3b	WA206 - Bobbin - for spray head atomiser	1
4	WA254 - WA254 - Rubber Isolator, Cloudmaker	1
5	WA250 - WA250 - Fixing Bracket, Cloudmaker	2
6	CD221 - CD221 - Cloudmaker Support Arm	1
7	CD220 - CD220 - Cloudmaker Pivot Arm	1

Water System - Fan Casing Spray

Model: 636HS Green Machine
From CIN: 1 To CIN: 12
Drawing: 525035-8 Revision:

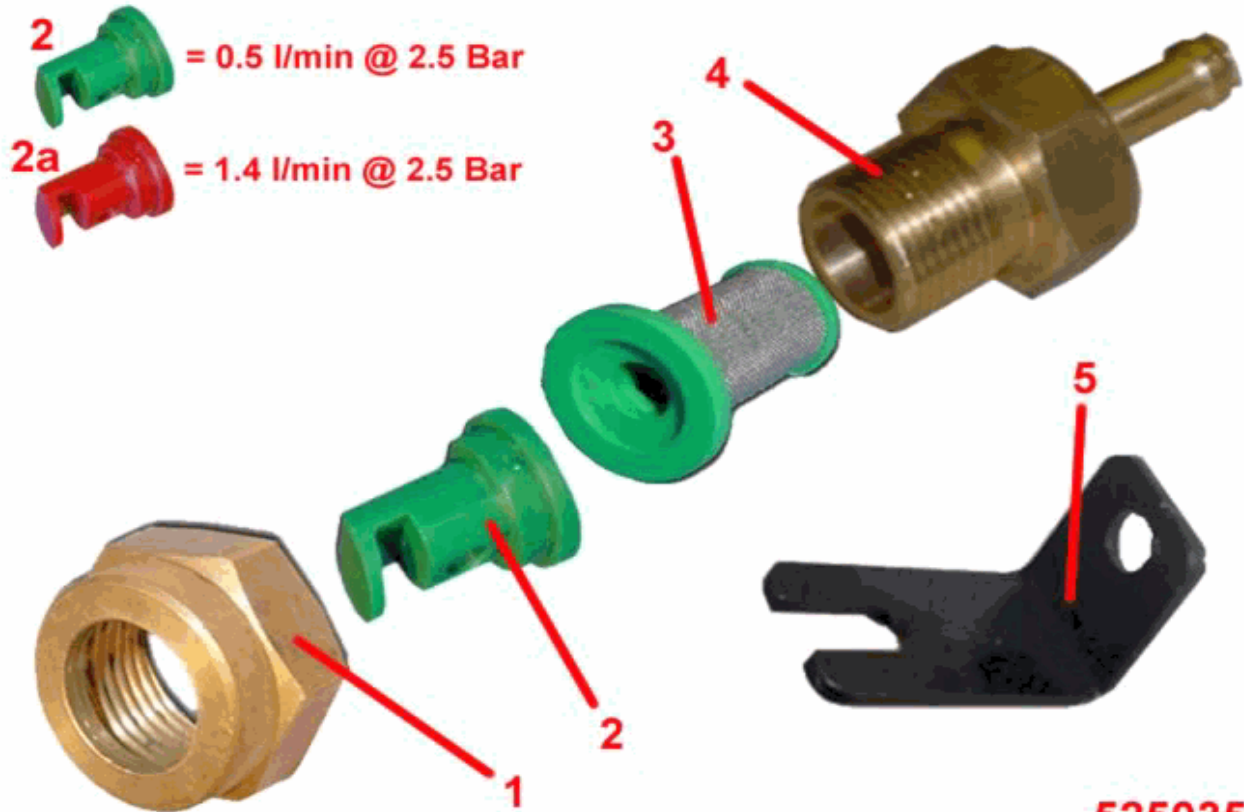

525035-8

1	WP016 - Cap Nut	1
2	WP060 - Spray Jet - Green	1
2a	WP221 - Spray Jet - Red	1
3	WP020 - Filter with anti-drip valve	1
4	WA103 - Nozzle Holder/Hosetail	1
5	VF075 - Water Nozzle Bracket	1

Water System - Front Brush Sprays

Model: 636HS Green Machine
From CIN: 1 To CIN: 12
Drawing: 525036-8 Revision:

525036-8

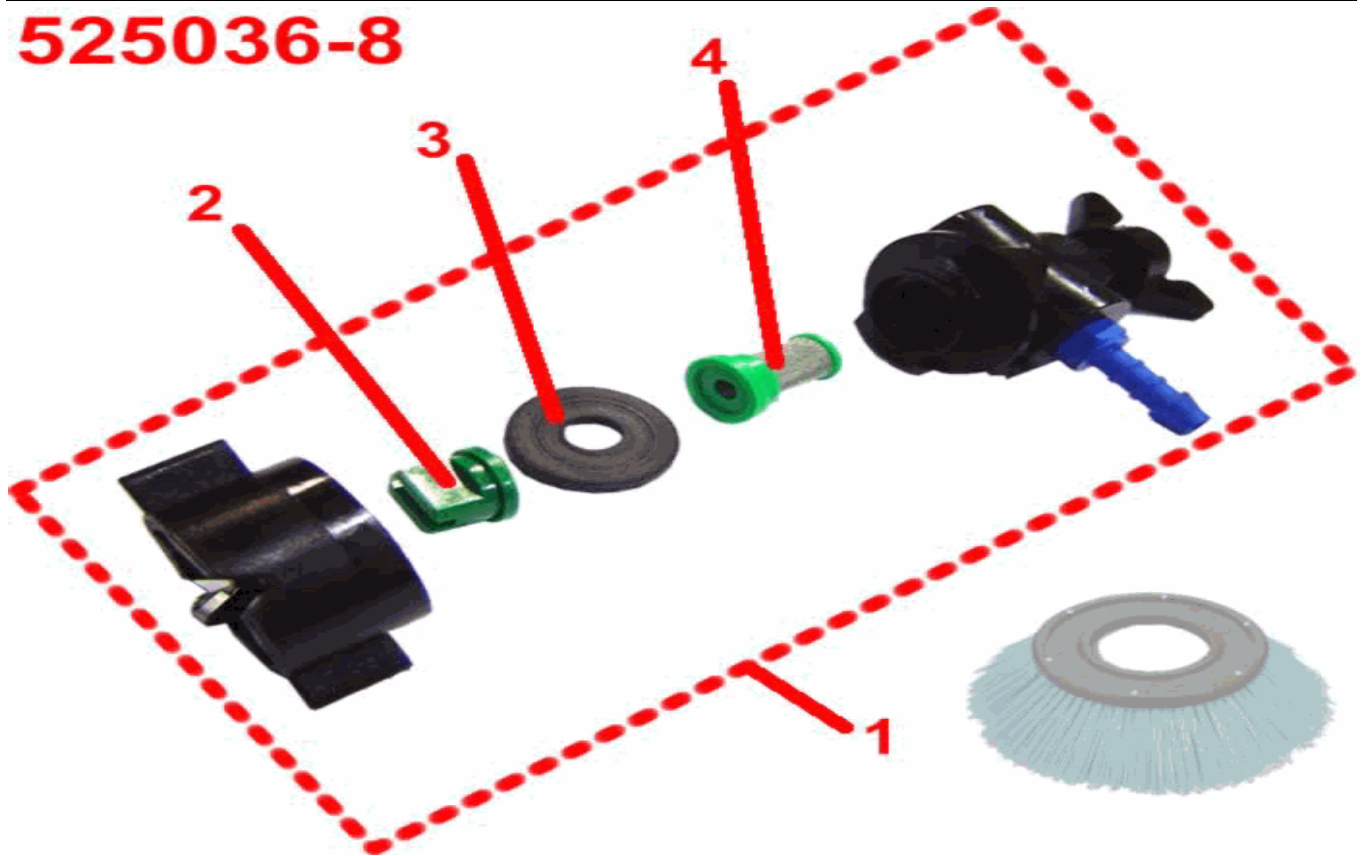

1	WP165 - Spray Nozzle Holder Assy (Brushes)	2
2	WP160 - Jet Spray	2
3	WP118 - - Sealing Disc	2
4	WP020 - Filter with anti-drip valve	2

Water System - General Arrangement

Model: 636HS Green Machine
 From CIN: 1 To CIN: 12
 Drawing: 636031-8 Revision:

636031-8

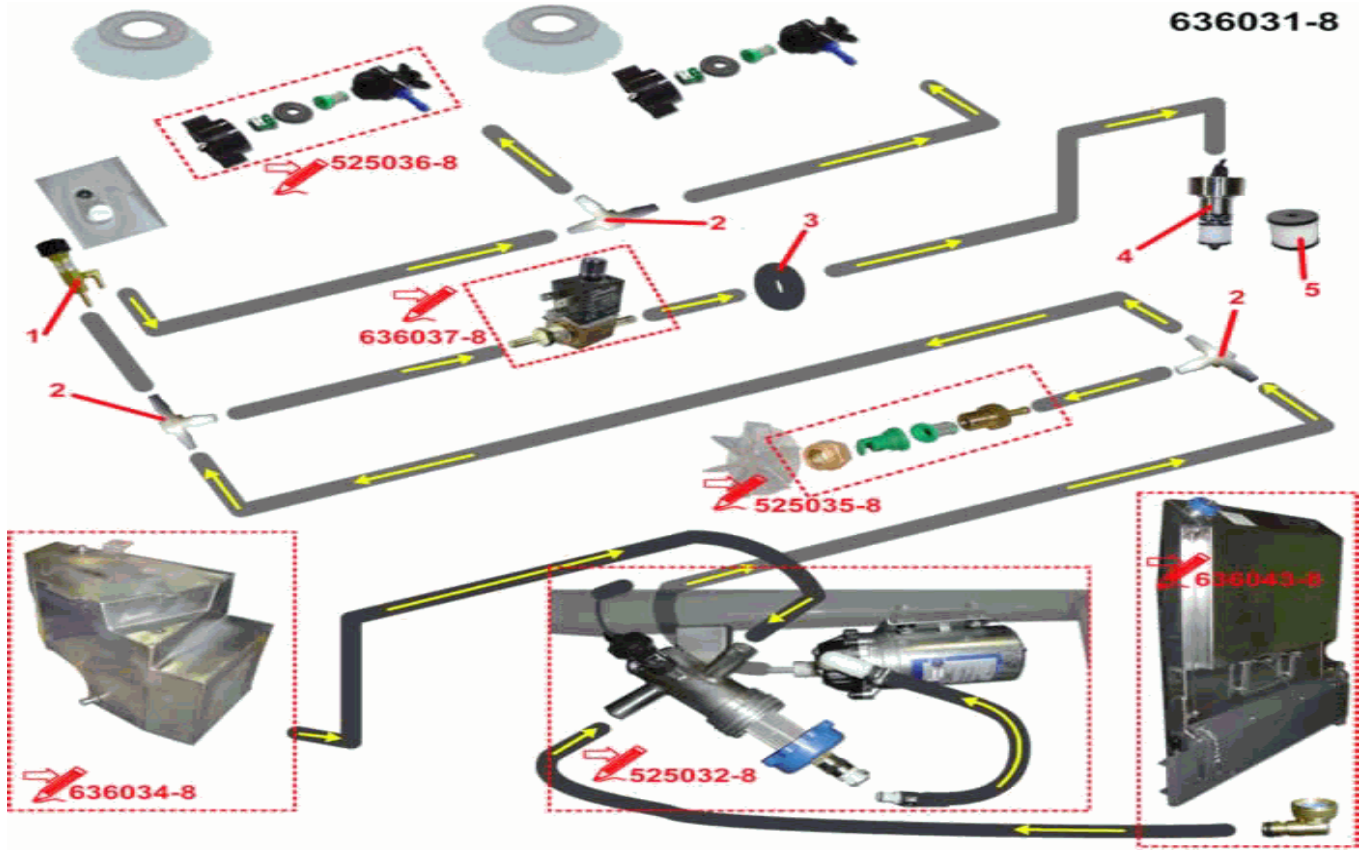

1	WA121 - Needle Valve	1
2	WP005 - Tee Piece 3.16, 3.16, 3.16	3
3	WA268 - Flow Restrictor Assembly	1
4	WA269 - Atomising Spray Assembly with plug	1
5	WA206 - Bobbin - for spray head atomiser	1

Water System - Main Water Tank

Model: **636HS Green Machine**
 From CIN: **1** To CIN: **12**
 Drawing: **636043-8** Revision:

636043-8

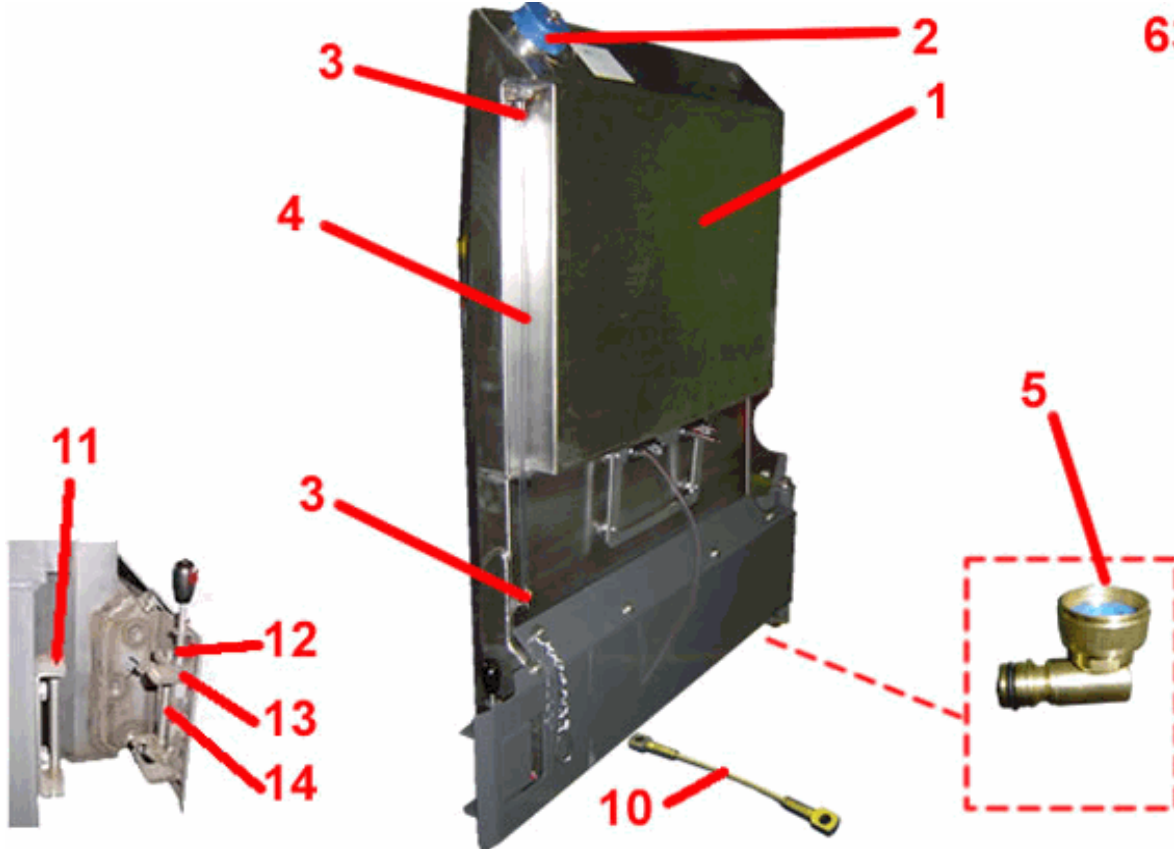

1	WA203 - Main Water Tank c/w Bumper - 636	1
1a	WA275 - Main Water Tank Assembly - 636	1
2	WA138 - Cap, Water Tank	1
3	WP100 - Elbow 1/8	2
4	PC081 - Water Level Tube	1
5	WA202 - Connector, 90 Swivel	1
10	CA032 - Restraining Cable	1
11	CA276 - Locking Pin Assembly	1
12	GG240 - Lever Knob, Black	1
12b	GG155 - Spring	1
13	CB937 - Locking Handle for Water Tank	1
14	CB904 - Locking Handle Pin	1

Water System - Side Water Tank

Model: 636HS Green Machine
From CIN: 1 To CIN: 12
Drawing: 636034-8 Revision:

636034-8

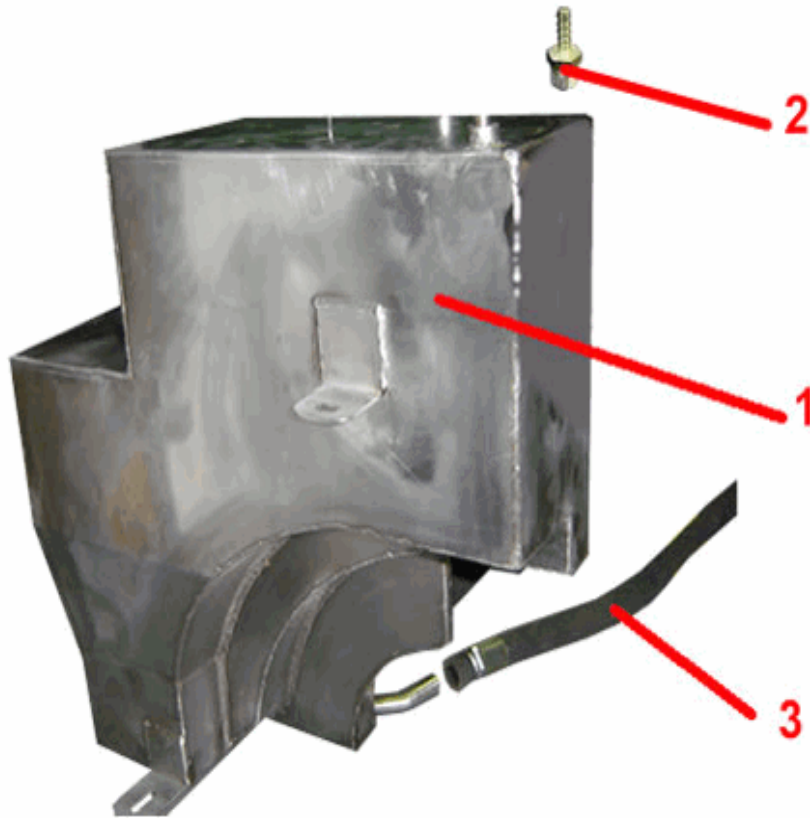

1	WA204 - Side Water Tank - 636	1
2	WP166 - Hose tail - 3/8 BSPT x 1/4" barb	1
3	WA128 - Water Hose, Small Water Tank to Manif	1

Water System - Solenoid Valve for Atomiser

Model: 636HS Green Machine
From CIN: 1 To CIN: 12
Drawing: 636037-8 Revision:

636037-8

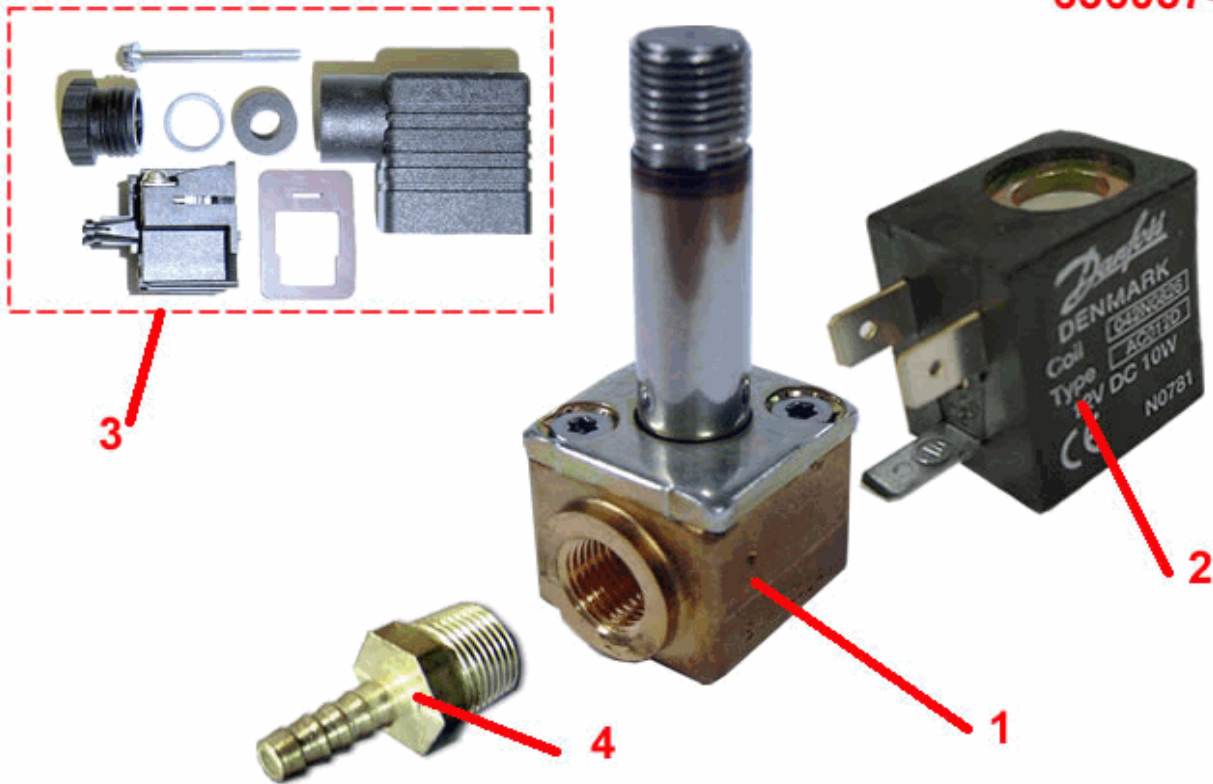

1	WP214 - Solenoid Valve	1
2	WP215 - Coil - Solenoid	1
3	WP216 - Plug - Solenoid Valve	1
4	WP217 - Hose Tail, 1/8	1

Water System - Water pump and manifold

Model: 636HS Green Machine
 From CIN: 1 To CIN: 12
 Drawing: 525032-8 Revision:

525032-8

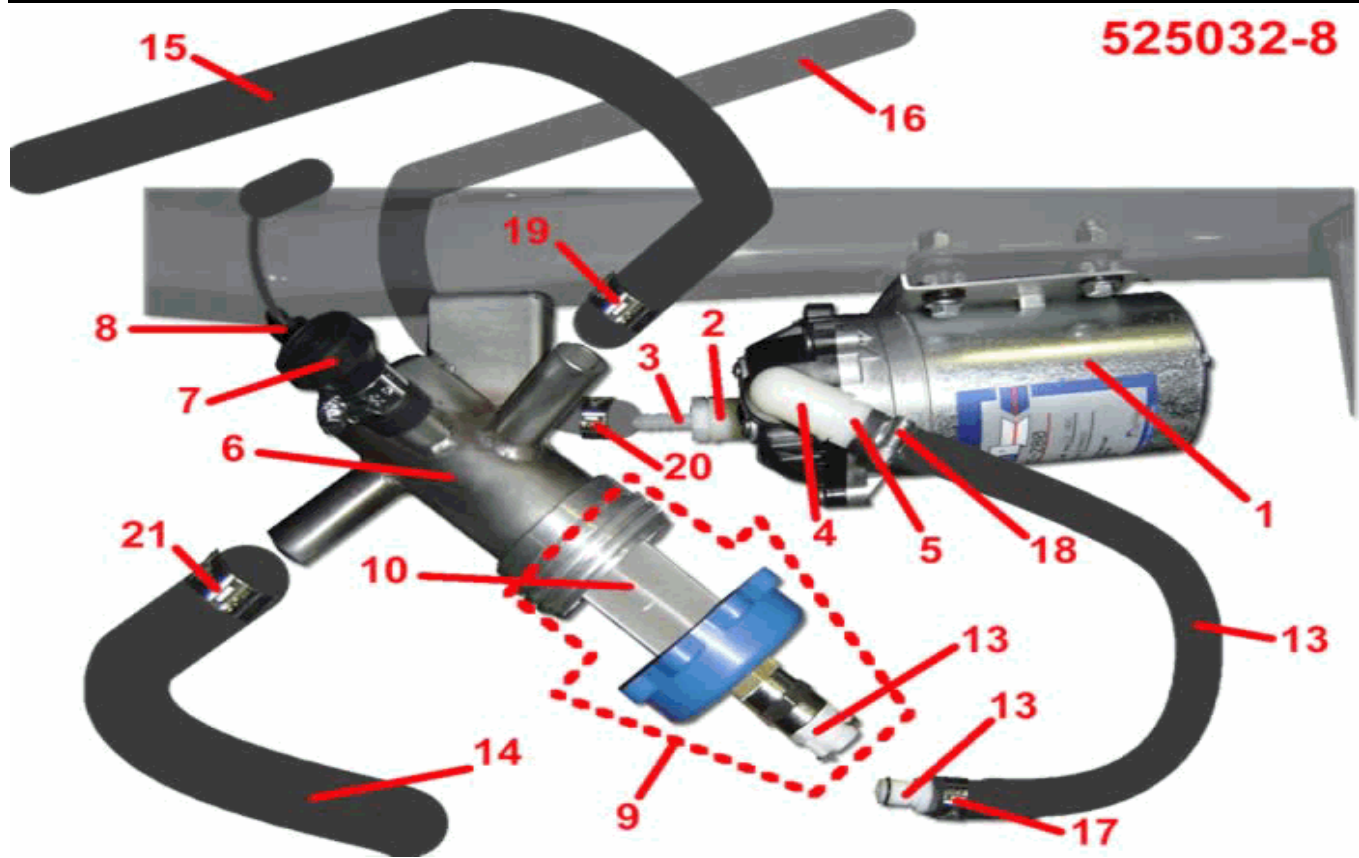

1	WP169 - Water Pump c/w Connector	1
2	WP112 - Elbow - 3/8 male - 3/8 female	1
3	WP163 - Nylon Hosetail 3/8 BSP x 1/4	1
4	WP112 - Elbow - 3/8 male - 3/8 female	1
5	WP164 - Nylon Hosetail 3/8 BSP x 3/8	1
6	WA107 - Manifold - Water Filter Assembly	1
7	GM400 - End Cap, Water Manifold	1
8	ES289 - Water Level Sensor c/w plug	1
9	WA130 - Strainer/Cap Assembly	1
10	WA041 - Strainer - Drain Cap	1
13	WA120 - Hose Assy. Water Manifold to Pump	1
14	WA127 - Water Hose - Large Water Tank/Manifol	1
15	WA128 - Water Hose, Small Water Tank to Manif	1
16	WA004 - Black Water Hose	0
17	GG045 - Hose Clamp (16mm)	1
18	GG045 - Hose Clamp (16mm)	1
19	GG051 - Hose Clamp (22mm to 30mm)	1
20	GG045 - Hose Clamp (16mm)	1
21	GG051 - Hose Clamp (22mm to 30mm)	1